



PROFESSIONAL EQUIPMENT  
CATALOGUE 23



Martellato



# PROFESSIONAL EQUIPMENT

PASTRY, ICE CREAM & BAKERY

 Martellato

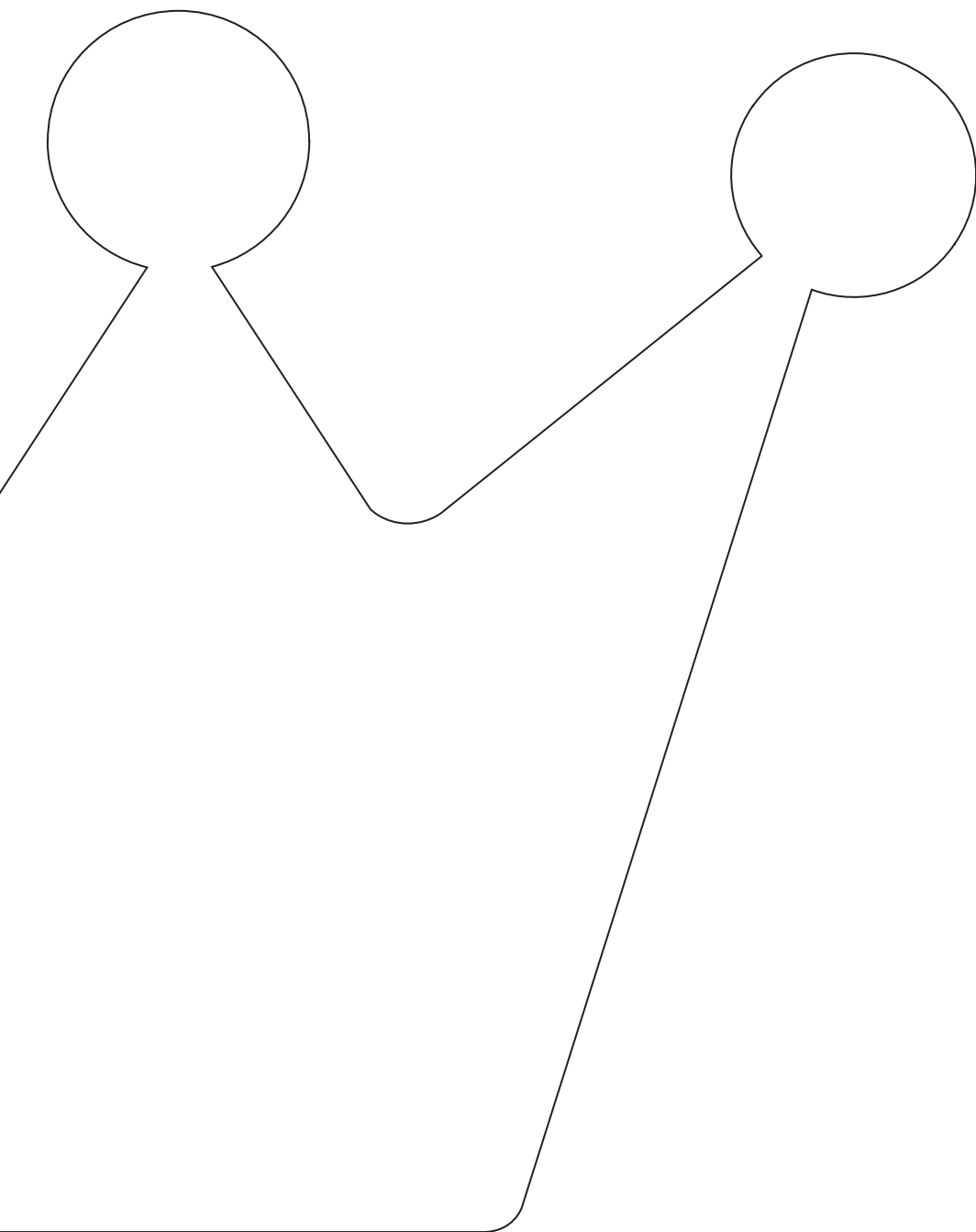

## VISION

Essere ambasciatori del Made in Italy nel mondo, offrendo prodotti che permettano ai pasticceri di esprimere al meglio il loro talento.

*Being ambassadors of Made in Italy all over the world, by offering products that allow pastry chefs to express their talent at their best.*

# 7000 PRODUCTS

Una gamma completa, in costante crescita, studiata e realizzata per soddisfare le esigenze dei professionisti. Il nostro catalogo, dedicato alle attrezzature da laboratorio pensate per i pasticceri ed adatte a tutti i professionisti, raccoglie un'ampia gamma di articoli tradizionali ed innovativi e vuole rappresentare il punto di riferimento per i diversi settori del comparto food.

*A complete range, constantly growing, designed and built for meet the needs of professionals. Our catalog, dedicated to laboratory tools designed for pastry chefs and suitable for all professionals, collects a wide range of traditional and innovative articles and wants to represent the reference point for the different sectors of the food industry.*

## MADE IN ITALY means Innovation and Design

Per noi, il "Made in Italy" è l'identità che esprime i valori del territorio e una particolare attenzione verso i prodotti. L'accurata scelta dei fornitori e delle nostre lavorazioni ci permette di offrire dei prodotti di alta qualità.

*Made in Italy is for us the identity that expresses the values of the territory and a particular attention to products. The careful choice of suppliers and our manufacturing allows us to offer high quality products.*



## CERTIFIED QUALITY

Qualità e sicurezza di tutti i nostri prodotti e servizi, così come specializzazione, ricerca e formazione sono costantemente controllate per garantire standard elevati nel rispetto delle Normative Europee sulla sicurezza alimentare, ambientale e gestione aziendale.

**Martellato è un'azienda con sistema di qualità certificato ISO 9001:2015.**

*The quality and safety of all our products and services, as well as the specialization, research and training are constantly monitored to guarantee high standards in accordance with European regulations of food and environmental safety and business management.*

**Martellato is a company with certified quality system ISO 9001: 2015.**

AMBASSADORS

# COLLABORATIONS



FRANK HAASNOOT



PHILIP KHOURY



KARIM BOURGI



MELISSA COPPEL



JAVIER GUILLÉN



WEI LOON TAN



CAMILA GARCIA ELIZALDE



NICOLAS NIKOLAKOPOULOS



DAVID PALLÀS



VINESH JOHNY

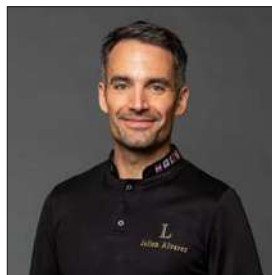

JULIEN ALVAREZ



ANNA GERASI



LUC DEBOVE



LUIGI BIASETTO



MASSIMO CARNIO



GIUSEPPE GAGLIARDI

ACADEMIES

# COLLABORATIONS



# SUSTAINABILITY

**L'impegno verso il Pianeta è parte della nostra filosofia.**

Utilizzare **PROCESSI DI PRODUZIONE PIÙ EFFICIENTI** può ridurre in maniera significativa l'inquinamento, i rifiuti e i consumi:

**Iniezione** - questo sistema azzerà gli scarti produttivi, in quanto la materia prima viene utilizzata interamente. Inoltre, l'alta produttività degli impianti comporta una riduzione dei consumi.

**Termoformatura** - consente di stampare articoli di forme e dimensioni diverse e, contemporaneamente, di valorizzare gli scarti utilizzandoli come materia prima secondaria per altre produzioni.

**Taglio laser** - consente lavorazioni precise che utilizzano al massimo la materia prima, ottimizzando la produzione e riducendo gli scarti.

Ci impegniamo ad utilizzare **MATERIALI ECOLOGICI E RICICLABILI** per ridurre l'impatto ambientale. Il materiale riciclabile diventa così una risorsa per nuove produzioni

***Commitment to the Planet is a part of our philosophy.***

*Using more efficient **PRODUCTION PROCESSES** can significantly reduce pollution, waste and consumption:*

***Injection** - this system reduces production waste to zero, as the raw material is used entirely. In addition, the high productivity of the equipment leads to a reduction in consumption.*

***Thermoforming** - it allows articles of different shapes and sizes to be printed and, at the same time, to valorise waste by using it as a secondary raw material for other productions.*

***Laser cutting** - it allows precise processing that makes maximum use of the raw material, optimising production and reducing waste.*

*Commitment to use **ECOLOGICAL AND RECYCLABLE MATERIALS** in order to reduce environmental impact. Recyclable material thus becomes a resource for new production.*



# REDUCE, REUSE, RECYCLE



Compiendo queste azioni, ogni azienda grande o piccola, ogni persona, tutti possiamo contribuire alla salvaguardia del pianeta.



*Any company, either big or small, any person, all of us can contribute in safeguarding the planet.*





# A GIFT FOR THE PLANET



## **Il pianeta è un luogo che va salvaguardato.**

Per questo abbiamo voluto dare un contributo condividendo con i nostri partner un importante progetto di riforestazione. Supportati dall'azienda Treedom, abbiamo acquistato 120 alberi di Cacao che sono stati piantati da contadini camerunensi in uno dei progetti agroforestali che l'azienda sostiene.

## **+ 120 ALBERI DI CACAO**

Grazie a questa iniziativa, inoltre, Martellato contribuisce al finanziamento di contadini Camerunensi, sostenendo il loro lavoro e quindi il loro sostentamento.

CON QUESTI ALBERI COMPENSEREMO

## **7 tonnellate di CO<sub>2</sub>**

PARI A QUELLA PRODotta DA UN TRENO CHE PERCORRE 440,040 KM.



**The planet is a place that must be preserved.**

Which is why we wanted to make a contribution by sharing an important reforestation project with our partners.

## + 120 COCOA TREES

Supported by the company Treedom, we purchased 120 cacao trees that were planted by Cameroonian farmers in one of the agroforestry projects the company supports. Thanks to this initiative, our company also contributes to the funding of Cameroonian farmers, supporting their work and thus their livelihoods.

WITH THESE TREES WE WILL COMPENSATE

# 7 tons of CO<sub>2</sub>

EQUAL TO THAT PRODUCED BY A TRAIN TRAVELLING 440,040 KM.

DISCOVER THE PROJECT



# Treedom

CERTIFICATE 2022



Martellato

## Martellato



### 120

Planted trees



### -7

Tons of CO<sub>2</sub>

[www.treedom.net](http://www.treedom.net)

treedom® friend  
2 0 2 2

# SOCIOECONOMIC VALUE

## **Martellato a fianco di Remix per generare valore sociale.**

Un'azienda socialmente responsabile concilia il proprio business con il rispetto e la valorizzazione delle persone.

Conscia di questo, Martellato srl dà il proprio contributo alla comunità sostenendo **Remix, una realtà che si occupa di inserimento lavorativo di persone fragili del territorio**, garantendo una filiera produttiva made in Italy, etica e sostenibile.

Nell'ambito dei progetti per l'accompagnamento e l'inserimento lavorativo, Remix ha sviluppato delle competenze altamente specifiche che dimostrano come anche le persone in situazione di fragilità possano contribuire positivamente all'economia del territorio, realizzando prodotti e servizi di qualità.

Martellato ha, quindi, scelto di affidare a Remix parte dell'assemblaggio dei propri prodotti. Acquistandoli sosterrete direttamente questa realtà e il nostro impegno verso una società più inclusiva.

## **Martellato alongside Remix to generate social value.**

*A socially responsible company reconciles its business with the respect and valorisation of people. Aware of this, Martellato srl makes its own contribution to the community by supporting **Remix, a reality that deals with the work placement of fragile people in the area**, guaranteeing a made in Italy, ethical and sustainable production chain.*

*As part of its projects for accompaniment and job placement, Remix has developed highly specific skills that demonstrate how even people in fragile situations can make a positive contribution to the local economy, producing quality products and services. Martellato has therefore chosen to entrust Remix with part of the assembly of its products. By purchasing them you will directly support this reality and our commitment to a more inclusive society.*

# BUY MORE & ASK FOR HIGH QUALITY



**REmix**  
SOLUZIONI INDUSTRIALI

[www.remixpadova.it](http://www.remixpadova.it)





# INDEX

CHOCOLATE	14
SEMIFREDDO & BAKING	194
ICE CREAM	268
SPECIAL EQUIPMENT	292
PROFESSIONAL TOOLS	334
DECORATION	398
BANQUETING & DISPLAY	418
CREATIVE COLORS	478



# CHOCOLATE

# PRALINES

**Su richiesta** alcuni modelli sono disponibili in versione **BPA FREE**.  
**On request**, some models are available in a **BPA FREE version**.



*mount*

in collaboration with  
**PHILIP KHOURY**

Vip

# VERY IMPORTANT PRALINE

Una linea di stampi che nasce dalla collaborazione tra Martellato e 4 Pastry Chef di fama internazionale per creare praline VIP.

From the collaboration between Martellato and 4 world renowned Pastry Chefs comes this line of moulds to create VIP pralines.

**Polycarbonate moulds 275 x 175 mm**



*dune*

KARIM BOURGI



*mount*

PHILIP KHOURY

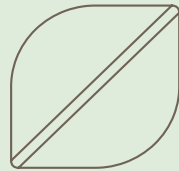

*flow*

WEI LOON TAN

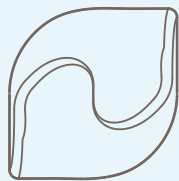

*flora*

JAVIER GUILLÉN

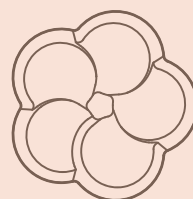

# dune

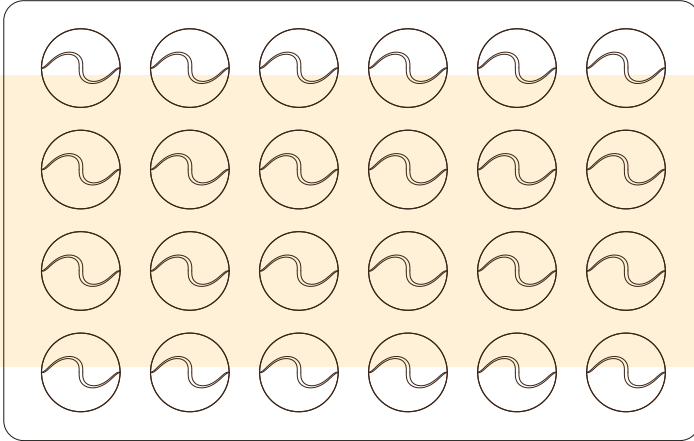

## DUNE

**MA1052**

ø 31 h 21 mm ~ 10 gr

Prod. 24 pcs



CREATED WITH

*Kavim Bourgi*

# mount

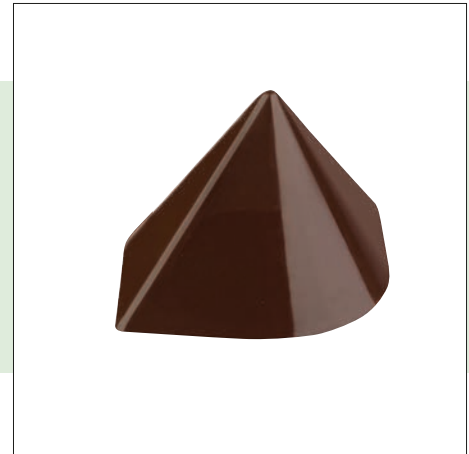
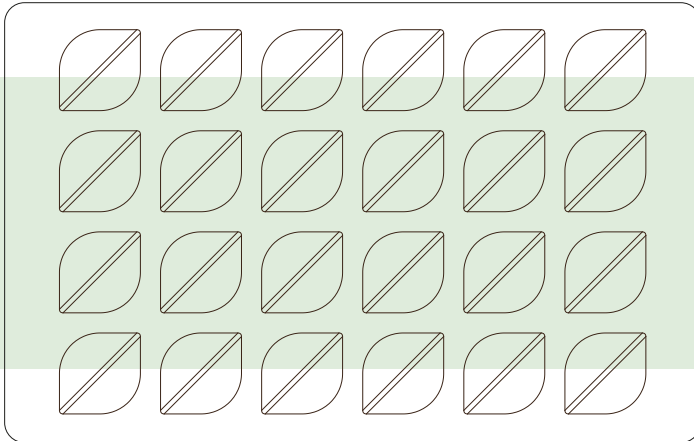

## MOUNT

**MA1047**

32 x 32 h 23 mm ~ 9 gr

Prod. 24 pcs



CREATED WITH

*Philip Khoury*

# flow

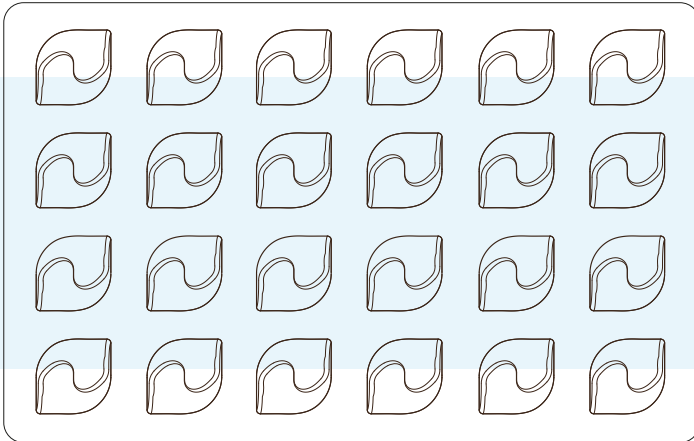

FLOW

**MA1051**

29 x 29 h 18 mm ~ 11 gr  
Prod. 24 pcs



CREATED WITH

*Wei Zoon Tan*

# flora

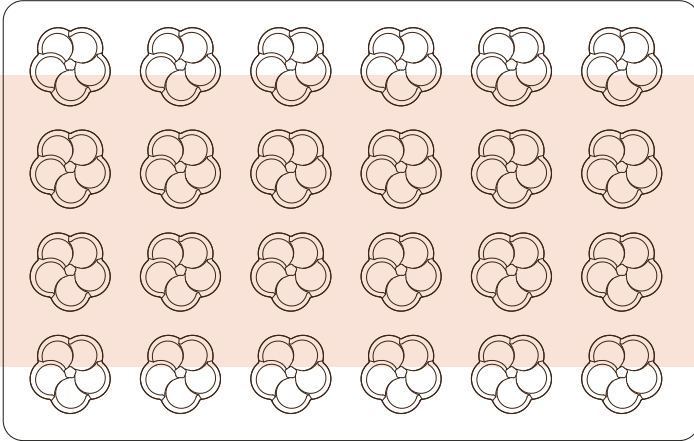

## FLORA

**MA1050**

30 x 31 h 18 mm ~ 11 gr  
Prod. 24 pcs



CREATED WITH

*Javier Guillén*



# Contemporary

Forme moderne uno stile minimale caratterizzano le praline della linea Contemporary.

Differenti modelli che ispirano e che si prestano a molteplici interpretazioni.

Modern shapes and a minimal style characterize the pralines of the Contemporary line.

Different models that inspire and that lend themselves to multiple interpretations.

**Polycarbonate moulds**  
**275 x 175 mm**

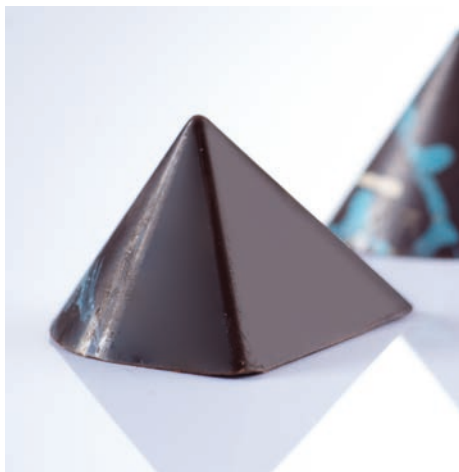

## SIDE

**MA1048**

32 x 32 h 23 mm ~ 9 gr  
Prod. 24 pcs



## ROCKET

**MA1044**

Ø 23 h 29 mm ~ 9 gr  
Prod. 28 pcs



## OBLIO

**MA1049**

Ø 32 h 23 mm ~ 8 gr  
Prod. 24 pcs



## THIMBLE

**MA1045**

Ø 23 h 28,5 mm ~ 11,5 gr  
Prod. 28 pcs

# Contemporary



## TURN

**MA1013**

40 x 19 h 16 mm - 10 gr

Prod. 25 pcs



## TWIST

**MA1014**

39,5 x 19 h 16 mm - 11 gr

Prod. 25 pcs



## FLAT

**MA1015**

40 x 18 h 16 mm - 11 gr

Prod. 25 pcs



## PILL

**MA1016**

40,5 x 18 h 16 mm - 10 gr

Prod. 25 pcs

# Contemporary



**MA1969**  
40 x 20 h 18 mm ~ 8 gr  
Prod. 30 pcs



**MA1970**  
40 x 18 h 15 mm ~ 9 gr  
Prod. 30 pcs



**MA1971**  
40 x 18 h 16 mm ~ 8 gr  
Prod. 30 pcs



**MA1999**  
39 x 20 h 16 mm ~ 7 gr  
Prod. 27 pcs



**MA1998**  
39 x 18 h 15,5 mm ~ 10 gr  
Prod. 30 pcs

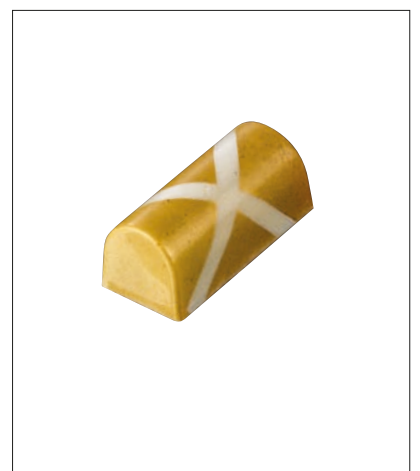

**MA1997**  
39 x 18 h 15,5 mm ~ 10 gr  
Prod. 30 pcs



# architecture

Ispirate dalle linee armoniose delle volte architettoniche, le nuove praline riproducono i diversi stili. Come i più famosi architetti potrete realizzare vere e proprie opere d'arte.

Inspired by the harmonious lines of architectural vaults, the new pralines reproduce different styles. Like the most famous architects, you can create real works of art.

**Polycarbonate moulds 275 x 175 mm**

## PAVILION

**MA1041**

27 x 27 h 20 mm ~ 10 gr

Prod. 28 pcs



## VAULT

**MA1042**

26,5 x 26,5 h 20 mm ~ 9 gr

Prod. 28 pcs



## CROSS

**MA1043**

26,5 x 26,5 h 18 mm ~ 11 gr

Prod. 28 pcs

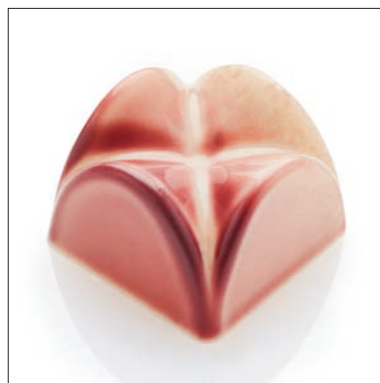



## DOME

**MA1038**

PRALINE/SNACK Ø 43 h 33 mm

~ 40 gr - Prod. 12 pcs



## STUD

**MA1039**

PRALINE/SNACK 45 x 45 h 33 mm

~ 34 gr - Prod. 12 pcs



## PASTRY

**MA1040**

PRALINE/SNACK Ø 45 h 33 mm

~ 38 gr - Prod. 12 pcs

*So Sweet!*



Polycarbonate moulds 275 x 175 mm



## SWEET 1

**MA1021**

ø 32 h 23 mm

10 gr - Prod. 25 pcs



## SWEET 2

**MA1022**

ø 32 h 21 mm

11 gr - Prod. 25 pcs



## SWEET 3

**MA1023**

ø 32 h 19,5 mm

11 gr - Prod. 25 pcs



## SWEET 4

**MA1024**

ø 33 h 22 mm

10 gr - Prod. 25 pcs

# waves

PRALINE

Polycarbonate moulds 275 x 175 mm



## WAVES 1

**MA1003**

26,9 x 59 x h 16 mm ~ 10,4 gr

Prod. 14 pcs



## WAVES 3

**MA1005**

24,3 x 61,5 h 15,4 mm ~ 9,8 gr

Prod. 16 pcs

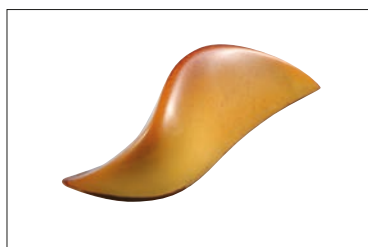

## WAVES 2

**MA1004**

27 x 59 h 17 mm ~ 7,9 gr

Prod. 16 pcs



## WAVES 4

**MA1006**

43,8 x 38,1 h 14,1 mm ~ 9,4 gr

Prod. 15 pcs



Polycarbonate moulds 275 x 175 mm

# Double



## DOMES

**MA4010**

38 x 26 h 19 mm ~ 11 gr

Prod. 4 pcs



## CUBES

**MA4011**

36 x 25 h 16 mm ~ 10 gr

Prod. 24 pcs



## HEARTS

**MA4012**

43 x 26 h 16 mm ~ 11 gr

Prod. 20 pcs



## HEARTS

**MA1993**

33 x 33 h 15 mm ~ 10 gr

Prod. 24 pcs



## JEMS

**MA1994**

6 square - 30 x 30 h 15 mm ~ 11 gr

6 oval - 42 x 24 h 15 mm ~ 10 gr

6 round - ø 32 h 15 mm ~ 10 gr

# Fruttissimi



## BANANA

MA1033

64 x 19 h 15 mm - 10 gr

Prod. 16 pcs



## PERA

MA1034

44 x 32 h 17 mm - 11 gr

Prod. 18 pcs

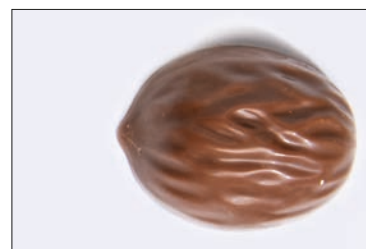

## NOCE

MA1035

37 x 29 h 17,5 mm - 11 gr

Prod. 18 pcs



## ARACHIDE

MA1036

50 x 23 h 15,5 mm - 11 gr

Prod. 20 pcs

Polycarbonate moulds 275 x 175 mm

## Geometric Pralines



### QUADRATO

MA1008

25 x 25 h 15,5 mm  
11 gr - Prod. 28pcs



### CERCHIO

MA1007

ø 30 h 15,5 mm  
11 gr - Prod. 28pcs



### OTTAGONO

MA1010

ø 30 h 15,5 mm  
11 gr - Prod. 28pcs



### TRIANGOLO

MA1009

33 x 29 h 15,5 mm  
8 gr - Prod. 24pcs

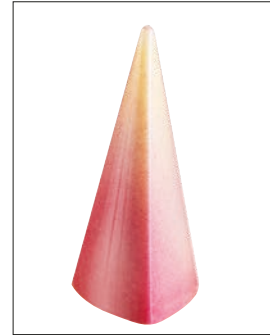

## TRIANGULAR

**MA4005**

25 x 26 h 55 mm - 11 gr  
Prod. 28 pcs

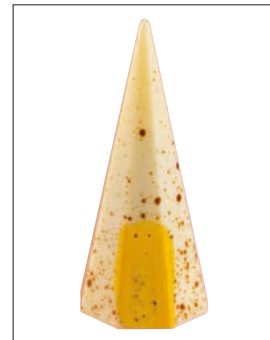

## OCTAGONAL

**MA4006**

25 x 25 h 55 mm - 11 gr  
Prod. 28 pcs



## CONE

**MA4007**

25 x 25 h 55 mm - 11 gr  
Prod. 28 pcs

# Tridimensional Shapes



Polycarbonate moulds  
275 x 175 mm with magnets



**20-3D2002**  
26 x 26 h 26 mm  
~ 8 gr - 28 pcs



**20-3D2003**  
26 x 26 h 26 mm  
~ 8 gr - 28 pcs



**20-3D3001**  
26 x 26 h 26 mm  
~ 8 gr - 28 pcs



**20-3D4001**  
28 x 24 h 24 mm  
~ 8 gr - 28 pcs

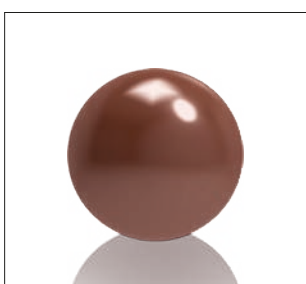

**20-3D2001**  
26 x 26 h 26 mm  
~ 8 gr - 28 pcs



**20-3D1001**  
23 x 30 h 23 mm  
~ 8 gr - 28 pcs



**20-3D1003**  
23 x 30 h 23 mm  
~ 8 gr - 28 pcs



**20-3D1002**  
23 x 32 h 23 mm  
~ 8 gr - 28 pcs



**20-3D5001**  
31 x 27 h 21 mm  
~ 8 gr - 28 pcs



**20-3D6001**  
32 x 18 h 28 mm  
~ 8 gr - 28 pcs



**20FRUIT01**  
ø 28 h 27 mm  
~ 12 gr - 28 pcs



**20FRUIT02**  
ø 26 h 36 mm  
~ 12 gr - 28 pcs



**20FRUIT03**  
Ø 28 h 32 mm  
~ 12 gr - 28 pcs



**20FRUIT04**  
Ø 25 h 31 mm  
~ 12 gr - 28 pcs



**20FRUIT05**  
Ø 27 h 30 mm  
~ 12 gr - 28 pcs

# Classic Shapes

Polycarbonate moulds 275 x 175 mm



**MA1002**

ø 30 h 19 mm  
~ 12 gr - 28 pcs



**MA1082**

35 x 20 h 17 mm  
~ 12 gr - 30 pcs



**MA1094**

ø 30 h 22 mm  
~ 14 gr - 28 pcs



**MA1530**

ø 26 h 19 mm  
~ 9 gr - 40 pcs



**MA1631**

30 x 18 h 15 mm  
~ 7 gr - 30 pcs



**MA1019**

25 x 25 h 23 mm  
~ 3 gr - 40 pcs



**MA1032**

38 x 22 h 15 mm  
~ 10 gr - 32 pcs



**MA1037**

ø 29 h 21 mm  
~ 8 gr - 40 pcs



**MA1046**

37 x 31 h 16 mm  
~ 12 gr - 28 pcs





**MA1637**

32 x 24 h 15 mm  
~ 8 gr - 30 pcs



**MA1638**

34 x 25 h 15 mm  
~ 8 gr - 30 pcs



**MA1612**

38 x 30 h 15 mm  
~ 9 gr - 20 pcs



**MA1607**

Ø 28 h 17,5 mm  
~ 9 gr - 24 pcs



**MA1618**

Ø 30 h 20 mm  
~ 9 gr - 24 pcs



**MA1633**

Ø 26 h 15 mm  
~ 8 gr - 35 pcs



**MA1527**

31 x 24 h 13 mm  
~ 8 gr - 35 pcs



**MA1529**

32 x 22 h 15 mm  
~ 8 gr - 42 pcs



**MA1616**

27 x 27 h 13 mm  
~ 9 gr - 28 pcs



**MA1621**

33 x 33 h 15 mm  
~ 9 gr - 24 pcs



**MA1907**

29,5 x 19 h 17 mm  
~ 7 gr - 28 pcs



**MA1617**

31 x 23 h 12 mm  
~ 9 gr - 24 pcs



**MA1620**

33 x 25 h 12 mm  
~ 8 gr - 24 pcs



**MA1622**

30 x 24 h 12 mm  
~ 9 gr - 24 pcs



**MA1625**

30 x 18 h 15 mm  
~ 8 gr - 30 pcs



**MA1927**

ø 26 h 23 mm  
~ 11 gr - 28 pcs



**MA1018**

52 x 26 x h 14 mm  
~ 9 gr - 21 pcs



**MA3007**

26 x 26 x h 12 mm  
~ 8,5 gr - 28 pcs



**MA1609**

30 x 23 h 18 mm  
~ 9 gr - 24 pcs



**MA1611**

Ø 30 h 15 mm  
~ 9 gr - 24 pcs



**MA1064**

35 x 23 h 16 mm  
~ 9 gr - 36 pcs



**MA1606**

30 x 30 h 12 mm  
~ 9 gr - 24 pcs



**MA1281**

17 x 12 h 5 mm  
~ 1 gr - 130 pcs



**MA1640**

48 x 18,5 h 19 mm  
~ 9 gr - 16 pcs



**MA1636**

30 x 30 h 15 mm  
~ 8 gr - 24 pcs



**MA1629**

30 x 18 h 15 mm  
~ 8 gr - 30 pcs



**MA1632**

30 x 18 h 15 mm  
~ 8 gr - 30 pcs



**MA1011**

50 x 25 h 15 mm  
~ 9 gr - 21 pcs



**MA1012**

54 x 24 h 16 mm  
~ 9 gr - 21 pcs



**MA1925**

27 x 31 h 18 mm  
~ 9,5 gr - 28 pcs



**MA1972**

26 x 26 h 20 mm  
~ 7 gr - 30 pcs



**MA1293**

Ø 23 h 21 mm  
~ 12 gr - 28 pcs



**MA1521**

Ø 28 h 18 mm  
~ 10 gr - 28 pcs



**MA1603**

32 x 23 h 13 mm  
~ 8 gr - 24 pcs



**MA1627**

35 x 20 h 15 mm  
~ 7 gr - 30 pcs



**MA1303**

27 x 27 h 18 mm  
~ 11 gr - 28 pcs



**MA1335**

35 x 22 h 15 mm  
~ 7 gr - 30 pcs



**MA1350**

Ø 25,5 h 21,5 mm  
~ 11 gr - 30 pcs



**MA1604**

30 x 25 h 15 mm  
~ 9 gr - 24 pcs



**MA1626**

31 x 20 h 16 mm  
~ 7 gr - 30 pcs



**MA1619**

29 x 29 h 12 mm  
~ 9 gr - 18 pcs



**MA1800**

21 x 21 h 18,5 mm  
~ 8 gr - 28 pcs



**MA1801**

26 x 20 h 21 mm  
~ 8 gr - 28 pcs



**MA1802**

Ø 23 h 18,5 mm  
~ 7 gr - 28 pcs



**MA1803**

26 x 20 h 21 mm  
~ 8 gr - 28 pcs



**MA1804**

Ø 25 h 18,5 mm  
~ 8 gr - 28 pcs



**MA1900**

29 x 19 h 16 mm  
~ 8 gr - 28 pcs



**MA1901**

27 x 23 h 14 mm  
~ 8 gr - 28 pcs



**MA1904**

30 x 20 h 17,5 mm  
~ 8 gr - 28 pcs



**MA1905**

30,5 x 19,5 h 18 mm  
~ 8 gr - 28 pcs



**MA1025**

33 x 22 h 20 mm  
~ 15 gr - 30 pcs



**MA1074**

38 x 28 h 18 mm  
~ 15 gr - 30 pcs



**MA1091**

Ø 28 h 23 mm  
~ 10 gr - 40 pcs



**MA1610**

Ø 29 h 18 mm  
~ 9 gr - 24 pcs



**MA1903**

28 x 20 h 17 mm  
~ 7 gr - 28 pcs



**MA1624**

28 x 32 h 15 mm  
~ 8 gr - 32 pcs



**MA1965**

25 x 25 h 15 mm  
~ 9 gr - 30 pcs



**MA1966**

25 x 25 h 15 mm  
~ 9 gr - 30 pcs



**MA1968**

25 x 25 h 15 mm  
~ 9 gr - 30 pcs



**MA1964**

Ø 27 h 20 mm  
~ 9 gr - 30 pcs



**MA1980**

25 x 25 h 13 mm  
~ 9 gr - 24 pcs



**MA1981**

Ø 35 h 15 mm  
~ 10 gr - 24 pcs



**MA1963**

Ø 27 h 20 mm  
~ 9 gr - 30 pcs



**MA1982**  
28 x 28 h 16 mm  
~ 11 gr - 28 pcs



**MA1983**  
24 x 24 h 18 mm  
~ 10 gr - 28 pcs



**MA1985**  
41 x 24 h 20 mm  
~ 10 gr - 20 pcs



**MA5000**  
ø 30 mm  
24 cavity



**MA5008**  
ø 35 mm  
15 cavity



**MA1987**  
35 x 23 h 17 mm  
~ 10 gr - 24 pcs



**MA2003**  
20 x 20 h 16 mm  
~ 6 gr - 28 pcs



**MA1988**  
30 x 30 h 8 mm  
~ 8 gr - 24 pcs



**MA1984**  
40 x 42 h 16 mm  
~ 10 gr - 15 pcs



**MA1986**  
30 x 30 h 11 mm  
~ 11 gr - 28 pcs



**MA1989**  
Ø 35 h 8 mm  
~ 8 gr - 24 pcs

**MA1020**  
25 x 25 h 18 mm  
~ 11 gr - 28 pcs

# MIXED Shapes

Polycarbonate moulds 275 x 175 mm

**Diamond**  
*chocolate jewels* 



**MA1994**

6 square - 30 x 30 h 15 mm ~ 11 gr

6 oval - 42 x 24 h 15 mm ~ 10 gr

6 round - Ø 32 h 15 mm ~ 10 gr



**MA1958**

30 x 24 h 18 mm

5 x 6 pcs ~ 10 gr



**MA1961**

30 x 25 h 25 mm

5 x 6 pcs ~ 8 gr



**MA1977**

30 x 24 h 11 mm

5 x 6 pcs ~ 7 gr

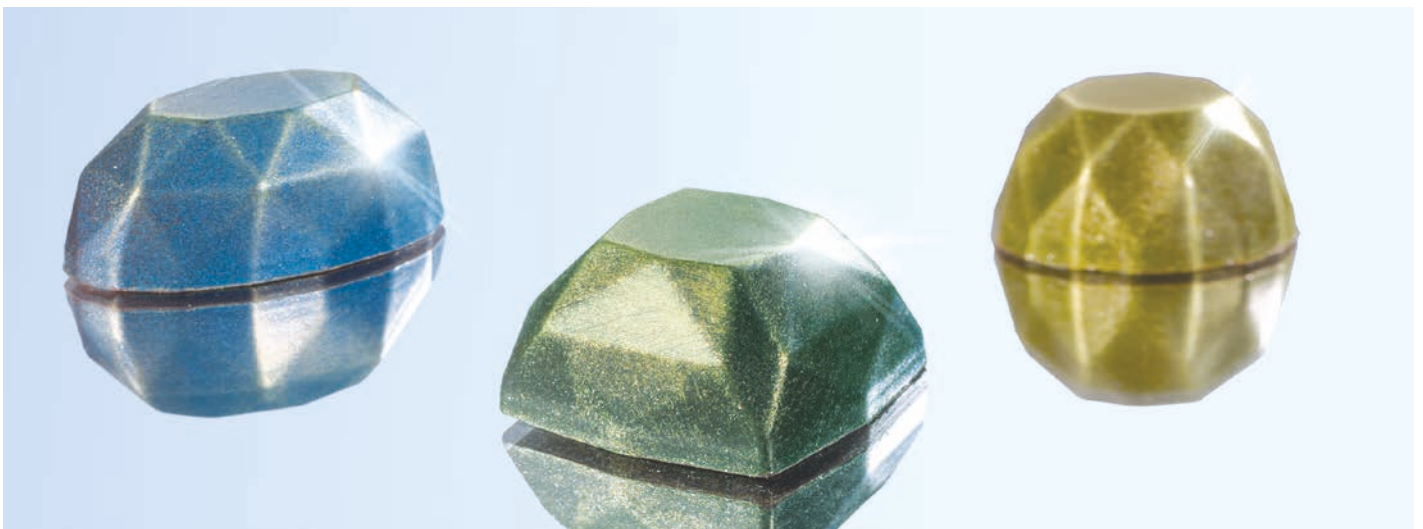

# Semispheres



Polycarbonate moulds 275 x 175 mm



## MA5003

Ø 20 mm - Prod. 45 pcs  
Peso semisfera piena/full  
semisphere weight ~ 2,5 gr

## MA5008

Ø 35 mm - Prod. 15 pcs  
Peso semisfera piena/full  
semisphere weight ~ 13 gr  
Peso semisfera con camicia/  
semisphere with shell ~ 8 gr

## MA5001

Ø 50 mm - Prod. 8 pcs  
Peso semisfera/semisphere  
weight ~ 17 gr  
Camicia/shell: 3 mm

## MA5006

Ø 80 mm - Prod. 4 pcs  
Peso semisfera/semisphere  
weight ~ 50 gr  
Camicia/shell: 3 mm

## MA5007

Ø 25 mm - Prod. 28 pcs  
Peso semisfera piena/full  
semisphere weight ~ 5 gr  
Camicia/shell: 3 mm

## MA5004

Ø 40 mm - Prod. 15 pcs  
Peso semisfera/semisphere  
weight ~ 11 gr  
Camicia/shell: 3 mm

## MA5010

Ø 55 mm - Prod. 6 pcs  
Peso semisfera/semisphere  
weight ~ 20 gr  
Camicia/shell: 3 mm

## MA5002

Ø 100 mm - Prod. 2 pcs  
Peso semisfera/semisphere  
weight ~ 80 gr  
Camicia/shell: 3 mm

## MA5000

Ø 30 mm - Prod. 24 pcs  
Peso semisfera piena/full  
semisphere weight ~ 9 gr

## MA5009

Ø 45 mm - Prod. 12 pcs  
Peso semisfera/semisphere  
weight ~ 13 gr  
Camicia/shell: 3 mm

## MA5005

Ø 60 mm - Prod. 6 pcs  
Peso semisfera/semisphere  
weight ~ 25 gr  
Camicia/shell: 3 mm

## Thermoformed moulds



### Kit 6 Stampi - Moulds - BIG

#### 20SF001

Ø 100 mm - prod 1 pc    Ø 150 mm - prod 1 pc  
Ø 130 mm - prod 1 pc    Ø 175 mm - prod 1 pc  
Ø 140 mm - prod 1 pc    Ø 200 mm - prod 1 pc



### Kit 4 Stampi - Moulds - SMALL

#### 20SF002

Ø 50 mm - prod 6 pcs    Ø 75 mm - prod 4 pcs  
Ø 65 mm - prod 4 pcs    Ø 90 mm - prod 2 pcs

Stampi - Moulds: 225x225 mm- 175x175 mm

Stampi - Moulds: 225x225 mm

# Love Day

Polycarbonate moulds 275 x 175 mm



## HEARTS

**MA1993**

33 x 33 h 15 mm

Prod. 24 pcs ~ 10 gr



## LOVE 2

**MA1526**

30,5 x 28 h 16,5 mm

Prod. 35 pcs ~ 8 gr



## LOVE 1

**MA1513**

34 x 33 h 11 mm

Prod. 28 pcs ~ 7 gr



## LOVE 3

**MA1613**

40 x 42 h 15 mm

Prod. 15 pcs ~ 9 gr



## LOVE 4

**MA1962**

31 x 27 h 14 mm

Prod. 30 pcs ~ 8 gr

# CHOCO

*Light*

Stampi termoformati per realizzare soggetti e decorazioni.  
Thermoformed mould for figures and decorations.



**90-1001**

Ø 23 h9  
18 pcs



**90-1004**

Ø 33 h9  
18 pcs



**90-1026**

52x42 h12  
8 pcs



**90-1212**

152x78 h8  
3 pcs

# Mum & Dad

Polycarbonate moulds 275 x 175 mm



## DEEP HEART

**MA1056**

27 x 27 h 16 mm

Prod. 28 pcs ~ 11 gr



## DAFNE

**MA1055**

ø 35 x h 16 mm

Prod. 24 pcs ~ 11 gr



## BOLT

**MA1054**

31 x 27 x h 16 mm

Prod. 24 pcs ~ 11 gr

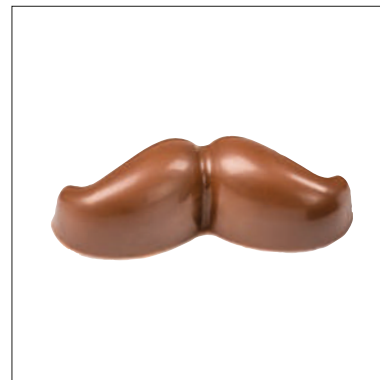

## JOE

**MA1053**

16 x 54 h 16 mm

Prod. 16 pcs ~ 10 gr

# Halloween Day

Polycarbonate moulds 275 x 175 mm



## SKULL

**MA1017**

37 x 28 h 18 mm

Prod. 20 pcs ~ 10 gr



## PUMPKIN

**MA1992**

34 x 31 h 15 mm ~ 9+9gr

Prod. 12+12 pcs



# XMAS Days

Polycarbonate moulds 275 x 175 mm



## STAR

MA1984

40 x 42 h 16 mm ~ 10gr

Prod. 15 pcs



## BOTTLE

MA3011

60 x 20,5 h 16 mm ~ 12 gr

Prod. 18 pcs



## GIFT

MA1991

26 x 26 h 20 mm ~ 11gr

Prod. 28 pcs



## SPHERE

MA1974

30 x 26 h 16,5 mm ~ 7gr

Prod. 5 x 6 pcs



## PANDORO

MA1990

Ø 30 h 25 mm ~ 10gr

Prod. 24 pcs



## TREE

MA1975

31 x 22 h 22 mm ~ 7gr

Prod. 5 x 5 pcs

# BARS

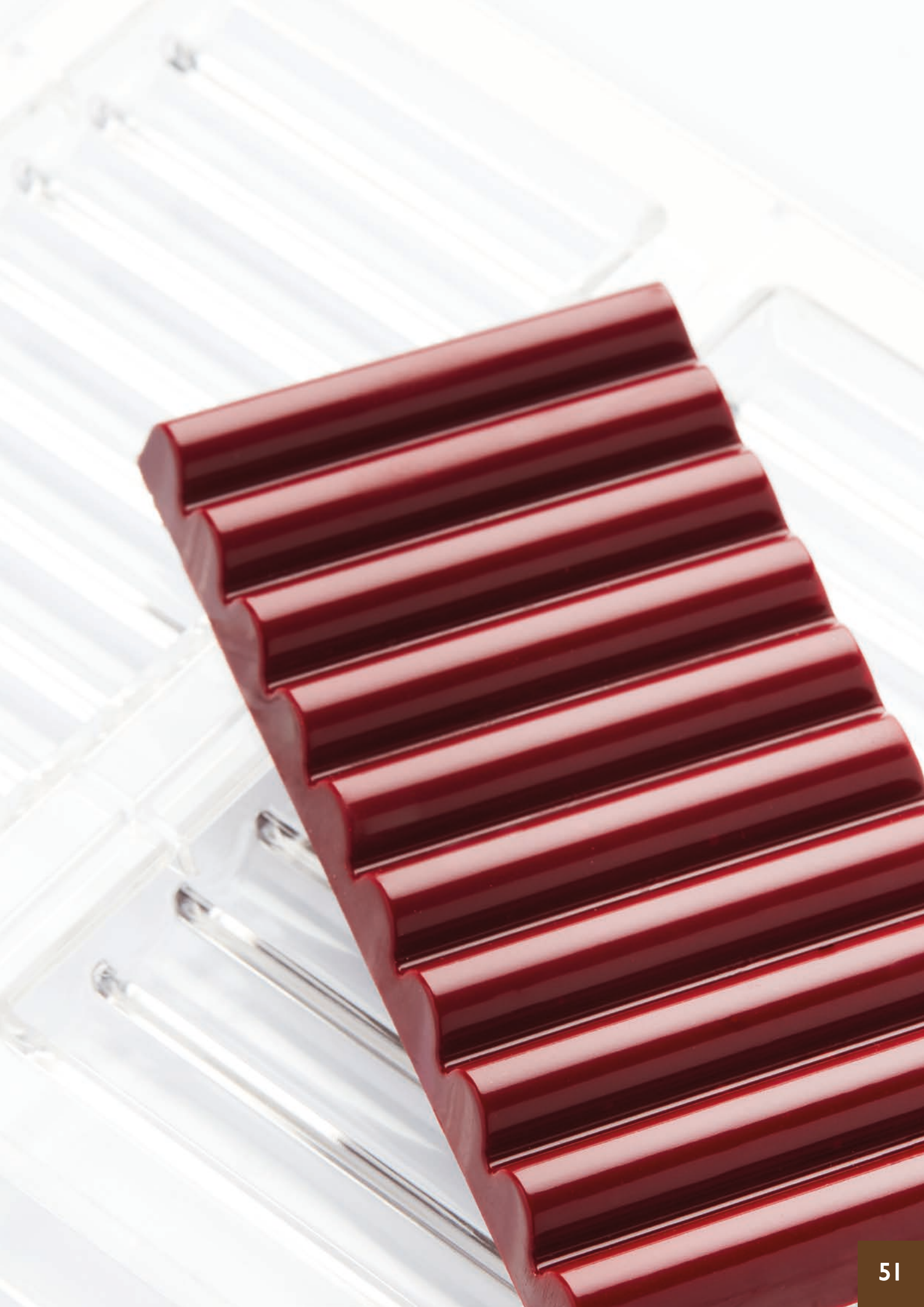

# EVOLUTION

Thinking beyond  
chocolate

Polycarbonate moulds 275 x 175 mm

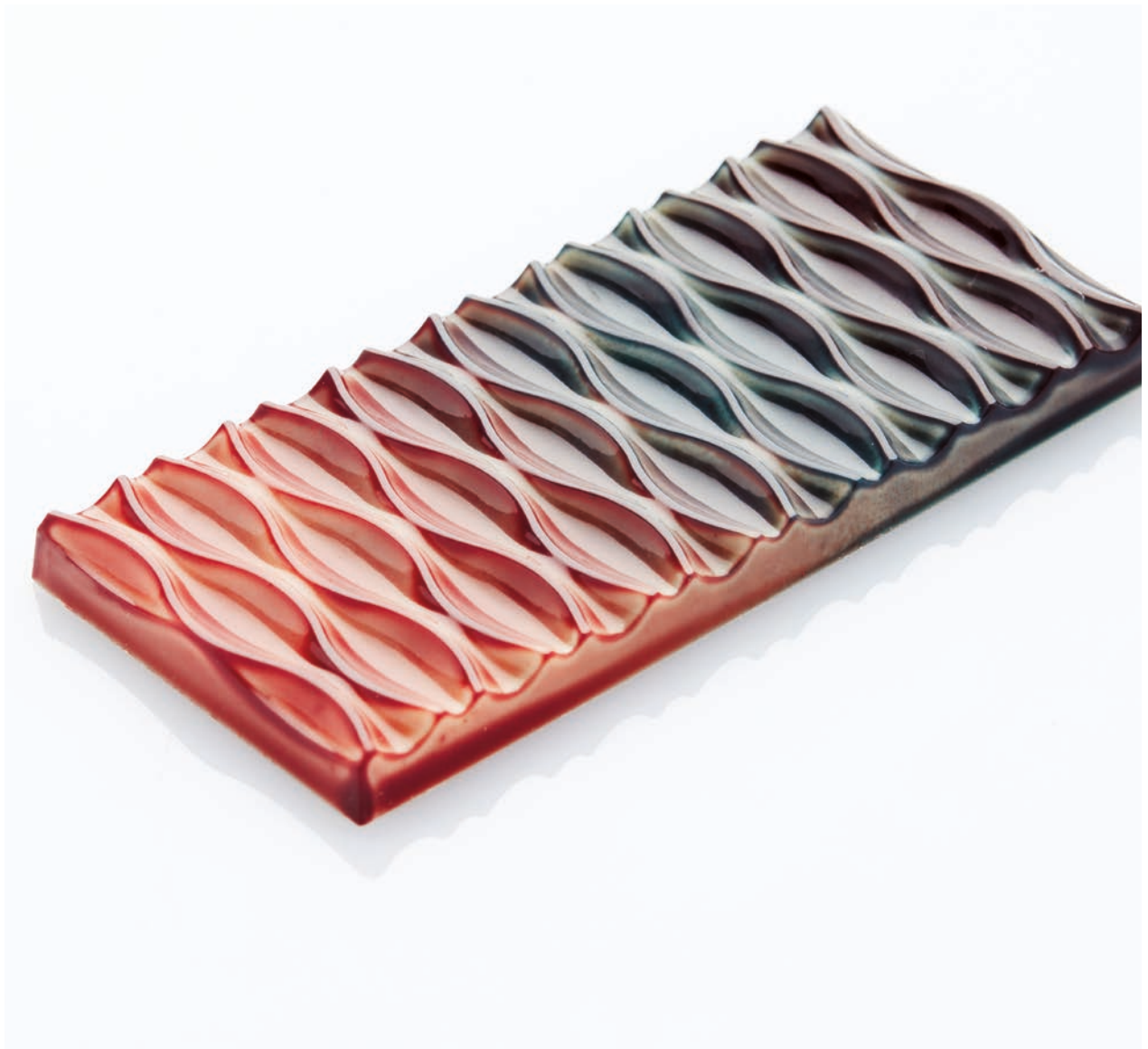

## SWING

**MA2028**

BAR - 142 x 68 h 10,5 mm  
Prod. 3 pcs ~ 100 gr

La collezione Evolution, nata per interpretare le tendenze del momento, si esprime con forme essenziali e geometrie. Le linee si incontrano ed intrecciano nelle nuove tavolette, che richiamano trame e sinuosità, oltre a giochi di volume.

The Evolution collection, created to interpret the trends of the moment, expresses itself with essential shapes and geometries. The lines meet and interlace in the new bars, which recall textures and sinuosity, as well as playing with games of volume.

## WEAVE

**MA2029**

BAR - 140 x 70 h 11 mm  
Prod. 3 pcs ~ 100 gr



## PEAK

**MA2027**

BAR - 142 x 68 h 12 mm  
Prod. 3 pcs ~ 100 gr



# EVOLUTION

Polycarbonate moulds 275 x 175 mm

## KALEIDOS

**MA2019**

BAR - 130 x 75 h 9 mm

Prod. 3 pcs ~ 85 gr



## EXAGON

**MA2015**

BAR - 140 x 68,5 h 13,5 mm

Prod. 3 pcs ~ 100 gr

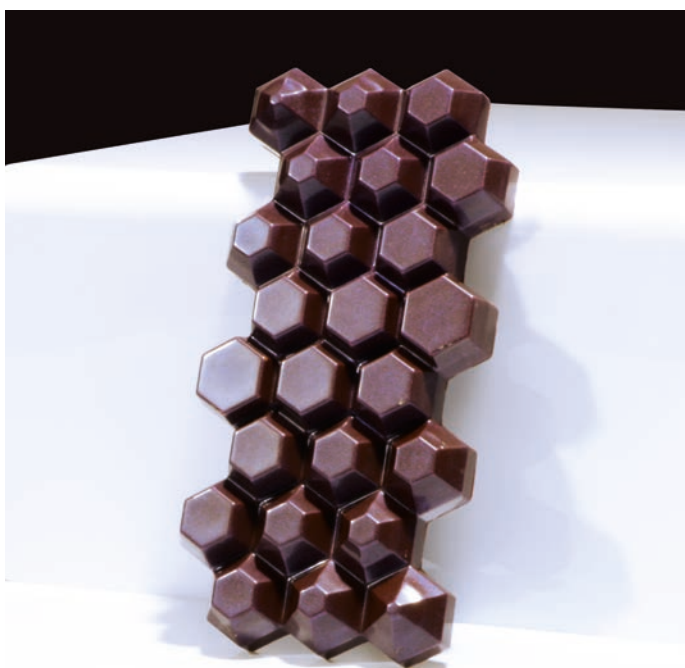



## MIRROR

**MA2022**

BAR - 138 x 72 h 9 mm

Prod. 3 pcs ~ 86 gr

# EVOLUTION

Polycarbonate moulds 275 x 175 mm

## STONE

### MA2013

BAR - 70 x 70 h 11 mm

Prod. 6 pcs ~ 50 gr



## SQUARE

### MA2014

BAR - 70 x 70 h 11 mm

Prod. 6 pcs ~ 50 gr



# SIGNS

Polycarbonate moulds 275 x 175 mm

## KUBE

### MA2016

BAR - 137 x 72 h 10 mm  
Prod. 3 pcs ~ 100 gr



## LOVE

### MA2017

BAR - 137 x 71 h 9,5 mm  
Prod. 3 pcs ~ 100 gr



# ICCONICS



Forme che si ispirano alle più iconiche tavolette. L'interpretazione di ogni cioccolatiere sarà l'elemento innovativo che sorprenderà e ne differenzierà lo stile.

Shapes inspired by the most iconic bars. The interpretation of each chocolatier will be the innovative element that will surprise and differentiate the style.

Polycarbonate moulds 275 x 175 mm

## KIT

### MA2023

BAR - 138 x 69 h 11 mm

Prod. 3 pcs ~ 100 gr

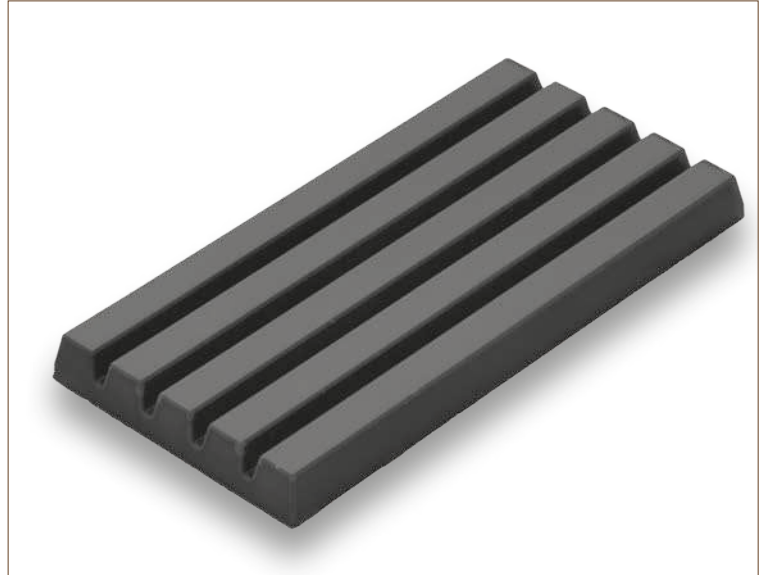

## SLOT

### MA2026

BAR - 140 x 70,5 h 10 mm

Prod. 3 pcs ~ 100 gr

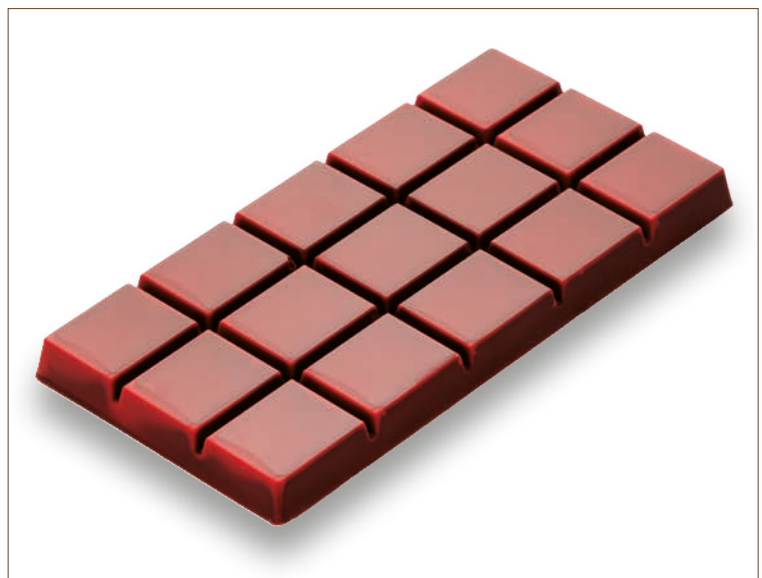

## LOG

### MA2024

BAR - 140 x 69,5 h 11 mm  
Prod. 3 pcs ~ 100 gr

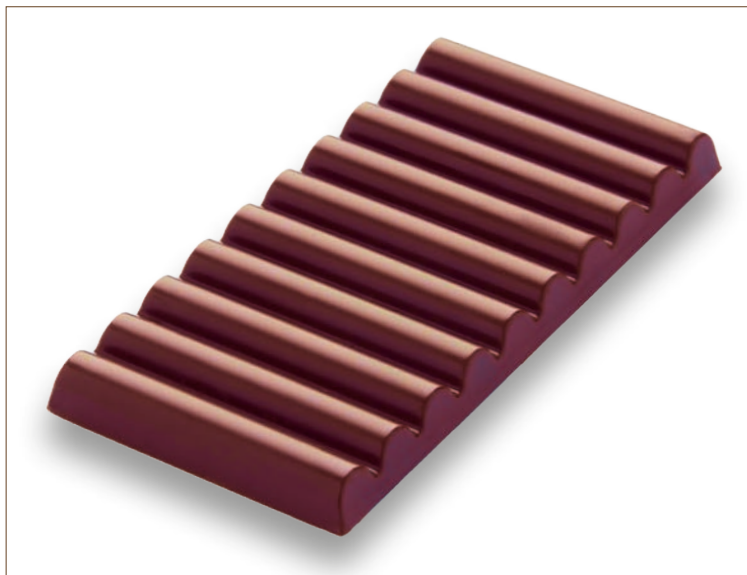

## BLOCK

### MA2025

BAR - 139 x 69,5 h 11,5 mm  
Prod. 3 pcs ~ 100 gr



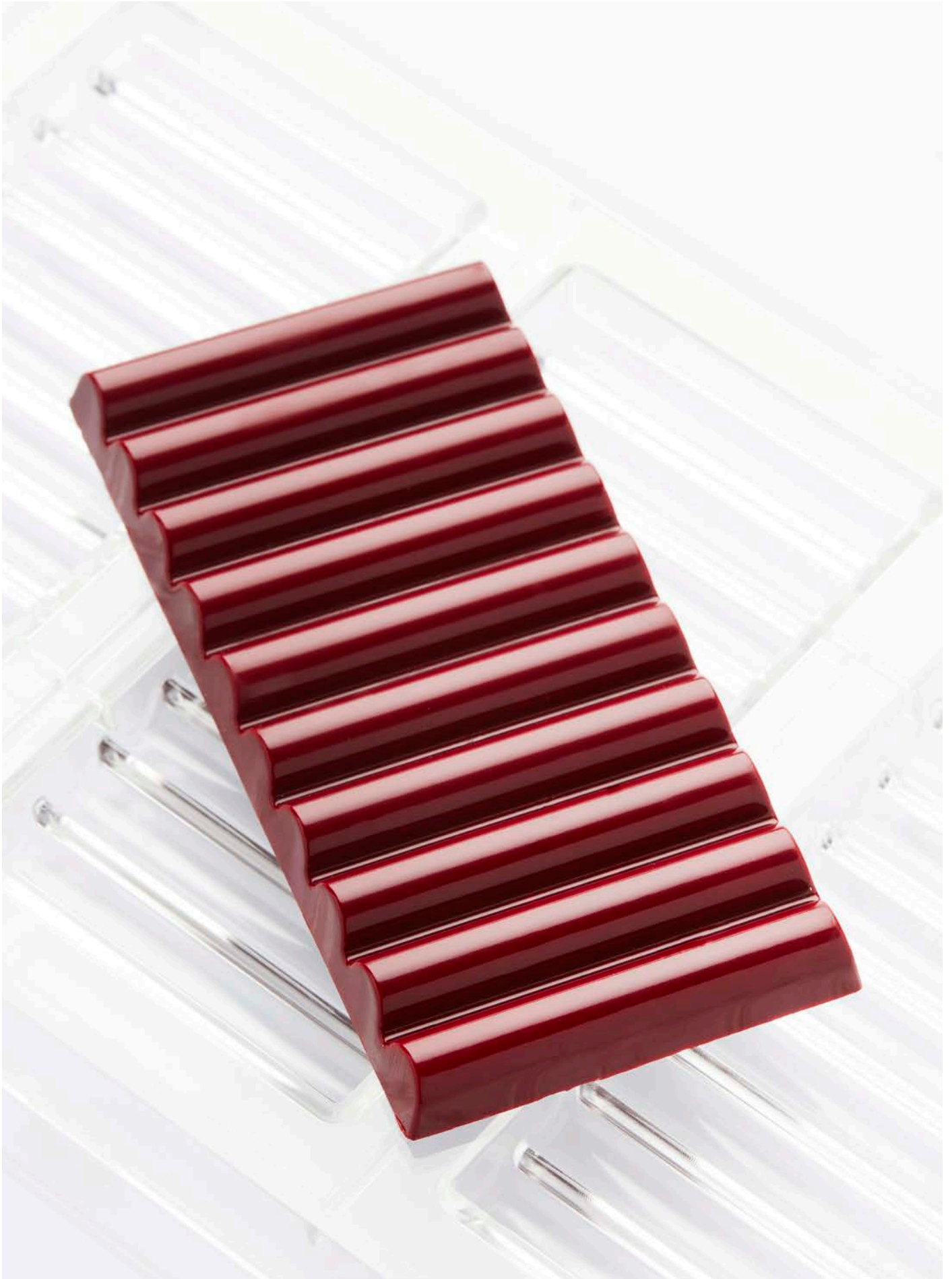



# CHOCO

## Style

Polycarbonate moulds 275 x 175 mm

### PYRAMID

**MA2009**  
138 x 72 h 11 mm  
Prod. 3 pcs ~ 80 gr



### LIQUID

**MA2008**  
117 x 71 h 13 mm  
Prod. 3 pcs ~ 80 gr



# PREstige

Polycarbonate moulds 275 x 175 mm



## MINI QUILTED

**MA2020**

BAR - 133 x 70 x h 10 mm

Prod. 3 pcs ~ 82 gr



## QUILTED

**MA2021**

BAR - 132 x 66 h 10 mm

Prod. 3 pcs ~ 80 gr

# choco and the City

Polycarbonate moulds 275 x 175 mm



## COCOA

MA2012

BAR - 130 x 70 x h 8 mm

Prod. 3 pcs ~ 83 gr



## CITY BAR

MA2011

BAR - 105 x 76 h 7 mm

Prod. 3 pcs ~ 80 gr

# Classic Shapes

Polycarbonate moulds 275 x 175 mm



**MA2010**

132 x 68 h 11 mm  
Prod. 3 pcs ~ 80 gr



**MA2000**

150 x 70 h 11 mm  
Prod. 3 pcs ~ 110 gr



**MA2001**

160 x 75 h 8 mm  
Prod. 3 pcs ~ 110 gr



**MA2004**

130 x 55 h 8 mm  
Prod. 4 pcs ~ 65 gr



**MA2005**

157 x 78 h 7 mm  
Prod. 3 pcs ~ 65 gr

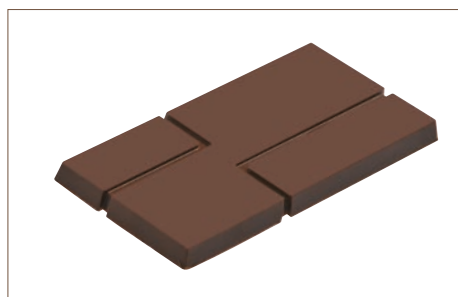

**MA1807**

154 x 74 h 10 mm  
Prod. 3 pcs ~ 125 gr

# Light Choco bars

Thermoformed moulds

Essenziali stampi in plastica termoformata per tavolette che garantiscono risultati perfetti. Leggeri e pratici, consentono di realizzare artigianalmente esclusive tavolette di cioccolato in modo semplice e veloce.

Essential thermoformed plastic moulds for bars that guarantee perfect results. Light and practical, they allow to quickly and easily create exclusive handmade chocolate bars.



**20TC004**  
150x70 h 8 mm  
Pack 5 pcs  
~100 gr



**20TC005**  
130x55 h 8 mm  
Pack 5 pcs  
~70 gr



**20TC006**  
110x50 h 8 mm  
Pack 5 pcs  
~45 gr



**20TC001**  
150x70 h10mm  
Pack 5 pcs  
~100 gr



**20TC002**  
150x70 h10mm  
Pack 5 pcs  
~100 gr



**20TC003**  
150x70 h10mm  
Pack 5 pcs  
~100 gr

# CHOCOLATE DISPLAYS

## VERTICAL

**80ET007**

91 x 226 h 73/93 mm

Cap. ~ 16 pcs



## HORIZONTAL

**80ET008**

181 x 226 h 43/156 mm

Cap. ~ 16 pcs (standing)/

~ 32 pcs (laying)

Con taschina removibile per inserire grafica personalizzata/ with removable pocket to insert customized graphics



## DOUBLE

**80ET009**

180 x 220 h 255 mm

Cap. ~ 16 pcs (standing)/

~ 32 pcs (laying)



**ET004**  
245x300 h 290mm  
Cap. ~ 45 pcs



**ET003**  
310x200 h 400mm  
Cap. ~ 48 pcs



**ET004B**  
315x410 h 370mm  
Cap. ~ 80 pcs



# SNACKS





## PRISMA

**MA7002**  
SNACK/BAR 202 x 32 h 19 mm  
Prod. 4 pcs ~ 70 gr



## BUBBLE

**MA7001**  
SNACK/BAR 200 x 23 h 17 mm  
Prod. 4 pcs ~ 70 gr



## KITE

**MA7000**  
SNACK/BAR - 200 x 23 h 18 mm  
Prod. 4 pcs ~ 62 gr



# CHOCO *line*



## CURVY

MA1920

96 x 22 h 17 mm - 10 pcs ~ 34 gr



## TRIANGLE

MA1922

96 x 22 h 17 mm - 10 pcs ~ 23 gr

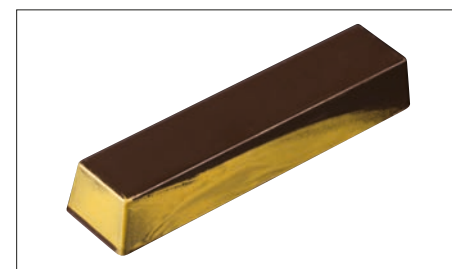

## PLAIN

MA1921

96 x 22 h 15,5 mm - 10 pcs ~ 34 gr



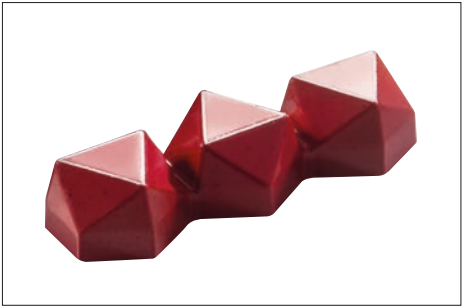

### MODERN BON

**MA1924**  
86,6 x 31,6 h 18 mm  
Prod. 8 pcs ~ 34,5 gr

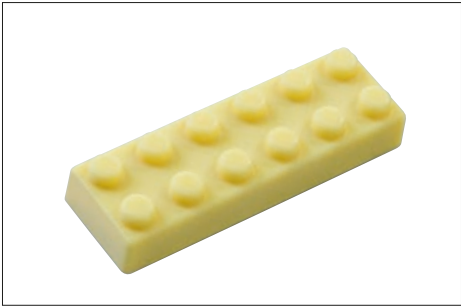

### BRICK

**MA1918**  
81 x 27 h 15 mm  
Prod. 12 pcs ~ 30 gr



### CLASSIC BON

**MA1926**  
90 x 30,8 h 16,5 mm  
Prod. 8 pcs ~ 30 gr



### SNACK CITY

**MA1919**  
113 x 39 h 10 mm  
Prod. 3 x 2 pcs ~ 45 gr



# Choco Leg

Polycarbonate moulds 275 x 175 mm

## FLAT

**MA6100**

198x35 h 23 mm

Prod. 4 pcs ~ 160 gr



## ROUND

**MA6101**

198x35 h 23 mm

Prod. 4 pcs ~ 150 gr

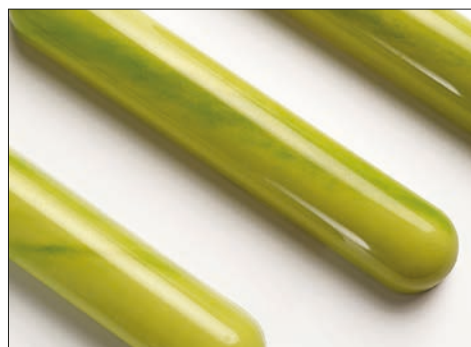

## CURVY

**MA6102**

198x35 h 23 mm

Prod. 4 pcs ~ 150 gr



## WAVY

**MA6103**

198x35 h 23 mm

Prod. 4 pcs ~ 150 gr



# Classic Shapes

Polycarbonate moulds 275 x 175 mm



**MA1923**

120 x 24 h 11 mm - 8 pcs ~ 33 gr



**MA1914**

100 x 26 h 16 mm - 8 pcs ~ 30 gr



**MA1915**

123 x 27 h 12 mm - 8 pcs ~ 30 gr



**MA1917**

115 x 24 h 15 mm - 8 pcs ~ 30 gr



**MA1805**

58 x 58 h 10 mm - 8 pcs ~ 35 gr



**MA1806**

119 x 29 h 10 mm - 8 pcs ~ 35 gr

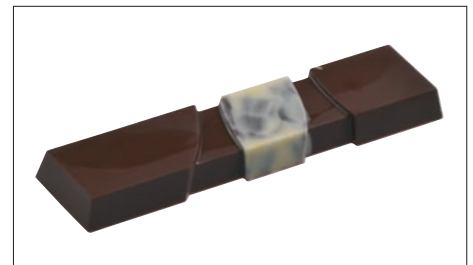

**MA1913**

119 x 29 h 10 mm - 8 pcs ~ 34 gr



**MA1916**

100 x 29 h 14 mm - 8 pcs ~ 30 gr



**MA1910**

99 x 33 h 10 mm - 8 pcs ~ 32 gr



**20-D015**

129 x h 17 mm - 12 pcs ~ 12 gr

# SPECIALS



# Napolitains



**MA6002**

42 x 25 h 6 mm - 20 pcs ~ 4 gr



**MA6005**

45 x 23 h 6 mm - 20 pcs ~ 4 gr



**MA2006**

50 x 26 h 3 mm - 16 pcs ~ 5 gr



**MA2007**

74 x 33 h 5 mm - 12 pcs ~ 13 gr





**MA2002**

32 x 32 h 4 mm - 24 pcs ~ 5 gr



**MA6004**

42 x 27 h 5 vmm - 20 pcs ~ 4 gr



**MA6003**

ø 39 h 4,5 mm - 15 pcs ~ 4 gr



**MA6001**

31 x 31 h 4,5 mm - 24 pcs ~ 4 gr



**MA6006**

34 x 34 h 4 mm - 24 pcs ~ 4 gr



# Circle disk

Polycarbonate moulds 275 x 175 mm

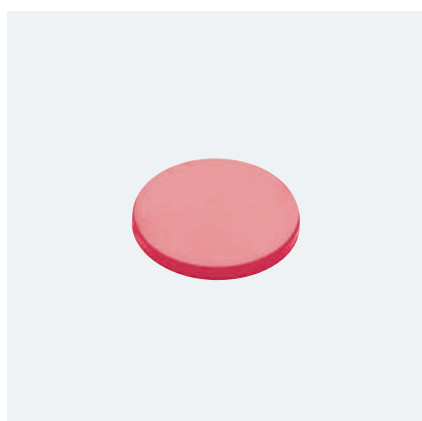

CIRCLE 30

**MA1026**

Ø 30 h 3 mm

Prod. 24 pcs ~ 2,5 gr



CIRCLE 33

**MA1027**

Ø 33 h 4 mm

Prod. 24 pcs ~ 4 gr



CIRCLE 40

**MA1028**

Ø 40 h 4 mm

Prod. 15 pcs ~ 5,5 gr



CIRCLE 75

**MA1030**

Ø 75 h 5 mm

Prod. 6 pcs ~ 25 gr

# MINI *Choco Fill*



**20GU007**  
Ø 37 h 14 mm - Prod. 15 pcs



**20GU008**  
27 x 27 h 31 mm - Prod. 28 pcs



**20GU009**  
33 x 33 h 14 mm - Prod. 24 pcs



**20GU500**  
44 x 56 h 39 mm - Prod. 12 pcs



**20GU501**  
Ø 40 h 18,5 mm - Prod. 15 pcs



**20GU502**  
44 x 55 h 23 mm - Prod. 12 pcs

Polycarbonate moulds 275 x 175 mm



**20GU001**  
Ø 32 h 37 mm - Prod. 20 pcs



**20GU002**  
ø 40 h 17 mm - Prod. 15 pcs



**20GU003**  
33 x 31 h 20 mm - Prod. 24 pcs

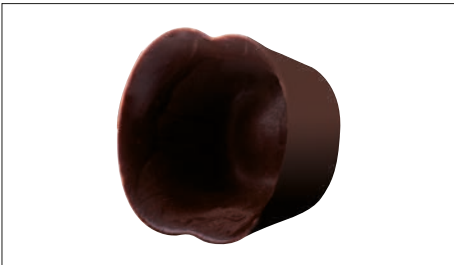

**20GU004**  
33 x 33 h 23 mm - Prod. 24 pcs



**20GU005**  
32 x 42 h 29 mm - Prod. 24 pcs



**20GU006**  
Ø 27 h 31 mm - Prod. 28 pcs



**MA1951**  
55 x 69 h 34 mm ~ 20 gr - 7 pcs



**MA1952**  
Ø 81 h 8 mm ~ 10 gr - 3 pcs



**MA3006**  
92 x 26 h 7 mm ~ 6 gr - 13 pcs



**MA1953**  
47 x 59 h 30 mm ~ 17 gr - 7 pcs



**MA1954**  
Ø 67 h 6,5 mm ~ 9 gr - 5 pcs



**SCC01**  
25 x 95 mm - 1 pc



# DECORATIONS



Frank Haasnoot



# STAMP

Chocolate Decoration Tool

---

Si arricchisce la gamma di strumenti creati da **Frank Haasnoot** per realizzare facilmente decorazioni in cioccolato. Con i nuovi timbri sarà possibile personalizzare le creazioni con messaggi d'auguri o dando identità agli ingredienti utilizzati.

The range of tools created by **Frank Haasnoot** for easily making chocolate decorations has been expanded. With the new stamps, it will be possible to personalise the creations with messages of good wishes or by giving identity to the ingredients used.



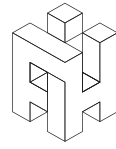

## HAPPY BIRTHDAY

20FH30S - Ø 3 cm  
20FH30L - Ø 6 cm



## VANILLA

20FH33L - Ø 6 cm



## COCOA

20FH32L - Ø 6 cm



## COFFEE

20FH34 - Ø 6 cm



## HAPPY VALENTINE

20FH37S - Ø 3 cm  
20FH37L - Ø 6 cm



## LOVE

20FH31S - Ø 3 cm  
20FH31L - Ø 6 cm



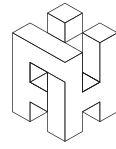

## HAPPY EASTER

20FH36S - Ø 3 cm  
20FH36L - Ø 6 cm



## SANTA

20FH38L - Ø 6 cm



## MERRY CHRISTMAS

20FH35L - Ø 6 cm



# COMB

## Chocolate Decoration Tool

---

Ideati da **Frank Haasnoot** per creare eleganti **decorazioni in cioccolato**.  
Realizzati in acciaio inox, i pettini consentono di produrre numerosi soggetti con un solo movimento.

Designed by **Frank Haasnoot** to create elegant **chocolate decorations**.  
Made of stainless steel, the combs allow you to produce many decorations with a single touch.

### BUTTERFLY



**20FH07S** - h 60 mm - prod. 3+3 pcs  
**20FH07L** - h 80 mm - prod. 3+3 pcs



Scopri come creare le decorazioni con i comb  
Find out how to create decorations with the combs

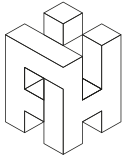

**FRANK HAASNOOT** for  **Martellato**

Frank Haasnoot



LEAF COMB



LEAF ECLAIR



**20FH01S** - h 60 mm - prod. 8 pcs  
**20FH01L** - h 80 mm - prod. 8 pcs



**20FH04** - h 25 mm - prod. 6 pcs



FEATHER COMB



FEATHER ECLAIR



20FH02S - h 60 mm - prod. 8 pcs  
20FH02L - h 80 mm - prod. 8 pcs



20FH05 - h 25 mm - prod. 6 pcs

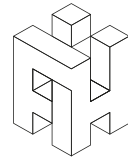

PETAL COMB



PETAL ECLAIR



**20FH03S** - h 60 mm - prod. 8 pcs  
**20FH03L** - h 80 mm - prod. 8 pcs



**20FH06** - h 25 mm - prod. 6 pcs

# TEMPLATE

## Chocolate Decoration Tool

---

Grazie a questi strumenti, realizzare **decorazioni in cioccolato** non è mai stato così facile.

Perfetti per finire torte e monoporzioni, le **dime in acciaio inox** consentono risultati stupefacenti, anche ai meno esperti.

Thanks to these tools, creating **chocolate decorations** has never been so easy. Perfect for decorating cakes and individual desserts, the **stainless steel templates** allow amazing results, even for the less experienced.



Scopri come creare le decorazioni con i template  
Find out how to create decorations with the templates

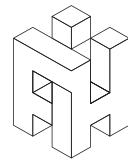

WAVE



DROP



20FH50 - 300 h 55 mm



20FH51 - 300 h 70 mm



ZIGZAG



HEARTBEAT



20FH54 - 300 h 70 mm



20FH53 - 300 h 85 mm



FLAME



20FH52 - 300 h 80 mm

# Decorations

Polycarbonate moulds 275 x 175 mm





**20-D001**  
63x h 21 mm  
18 pcs 2/3 gr



**20-D002**  
66x h 20 mm  
18 pcs 2/3 gr



**20-D003**  
64x h 26 mm  
16 pcs 2/3 gr



**20-D004**  
63x h 23 mm  
18 pcs 2/3 gr



**20-D005**  
72x h 24 mm  
18 pcs 2/3 gr



**20-D006**  
72x h 19 mm  
18 pcs 2/3 gr



**20-D007**  
66x h 21 mm  
18 pcs 2/3 gr



**20-D008**  
65x h 22 mm  
18 pcs 2/3 gr



**20-D009**  
70x h 19 mm  
18 pcs 2/3 gr



**20-D010**  
50 x h 38 mm  
14 pcs 2/3 gr



**20-D011**  
62 x h 31 mm  
18 pcs 2/3 gr



**20-D012**  
50 x h 49 mm  
12 pcs 2/3 gr



**20-D021**  
73 x 72 54 x 51 35 x 30  
mm - 3 x 6 pcs ~ 2 gr



**20-D014**  
ø 50 mm  
11 pcs ~ 2 gr



**20-D023**  
66 x 79 46 x 58 28 x 36  
mm - 3 x 6 pcs ~ 2 gr



**20-D024**  
70 x 38 mm  
12 pcs ~ 2 gr



**20-D025**  
73 x 44 50 x 24 mm  
10+10 pcs ~ 2/gr

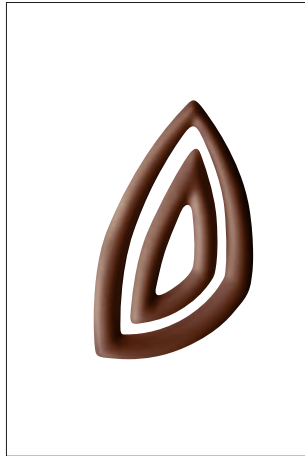

**20-D026**  
41 x 73 20 x 50 mm  
10+10 pcs ~ 2 gr



**20-D027**  
38 x 72 33 x 20 mm  
6/6+6/6 pcs ~ 2 gr



**20-D013**  
47 x h 39 mm  
15 pcs ~ 2 gr



**20-D028**  
22 pcs mix

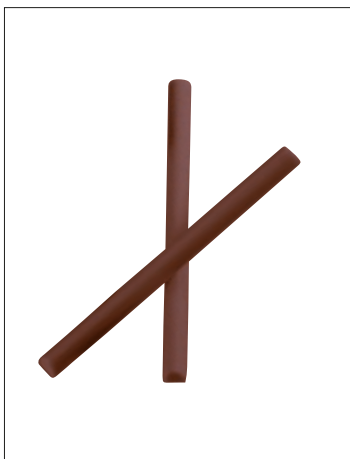

**20-D016**  
 Prod. 22 pcs ~ 3/4 gr  
 110 x h7 mm

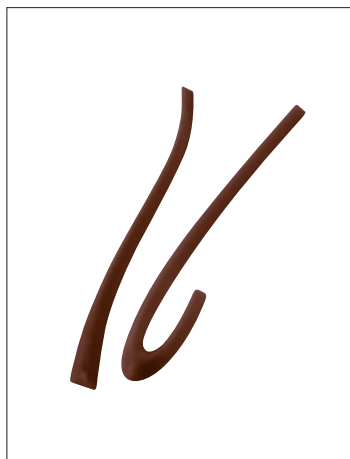

**20-D017**  
 Prod. 8+8 pcs ~ 2/3 gr  
 108 x 17 - 101 x 18 mm



**20-D019**  
 Prod. 13+13 pcs ~ 2/3 gr  
 123 x 4 - 109 x 5 mm

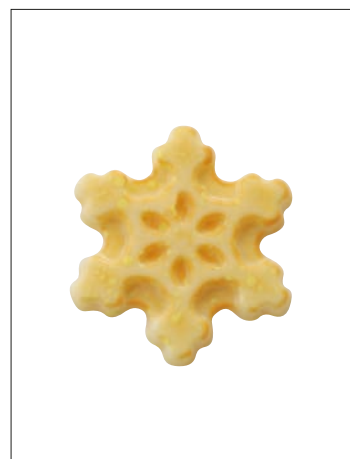

**20-D029**  
 14 pcs ø 30 h 4 mm ~ 21 gr  
 12 pcs ø 40 h 4 mm ~ 2 gr

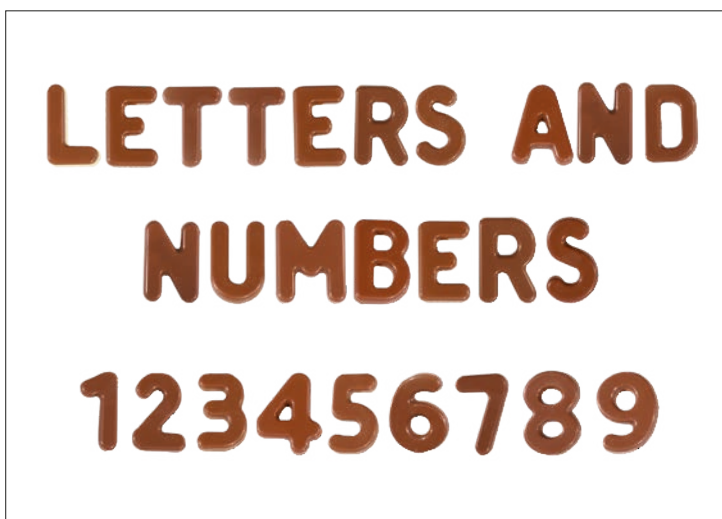

**MA3005**  
 letters and numbers h 30 mm

# Chablon project

Tappeti in flessibile silicone alimentare per **decorazioni**, con **forme perfette e precise**, pensati per il cioccolato ma adatti anche ad isomalto, caramello, pastigliaggio ed altri impasti che consentiranno di personalizzare la produzione facilmente.

The flexible food silicone mats for **decorations** with **perfect and precise shapes** are designed for chocolate, but work also for isomalt, caramel, pastillage and other doughs in order to easily personalize the production.

## HEARTS CHASIL33



8 pcs  
45x43 mm



8 pcs  
40x39 mm



12 pcs  
35x34 mm

## SPOT CHASIL32



16 pcs  
60x63 mm



**Tappeto in silicone** 390x290 mm  
Spessore 1,5 mm

**Silicone mat** 390x290 mm  
Thickness 1,5 mm



**FLOWERS**

**CHASIL34**

52x49 mm - 8 pcs  
42x40 mm - 8 pcs  
33x31 mm - 12 pcs



**BUTTERFLIES**

**CHASIL31**

60x44 mm - 8 pcs  
54x40 mm - 8 pcs  
46x34 mm - 12 pcs



**HEARTS**

**CHASIL33**

45x43 mm - 8 pcs  
40x39 mm - 8 pcs  
35x34 mm - 12 pcs



**SQUARE**

**CHASIL25**

60x60 mm - 12 pcs

**CHASIL24**

37,5x37,5 mm - 30 pcs

**CHASIL23**

25x25 mm - 63 pcs



**OBLONG**

**CHASIL20**

132x32 mm - 10 pcs

**CHASIL27**

125x25 mm - 18 pcs

**CHASIL28**

60x18 mm - 36 pcs



**ROUND**

**CHASIL 16**

Ø 26 mm - 48 pcs

**CHASIL 17**

Ø 36 mm - 36 pcs

**CHASIL 18**

Ø 42 mm - 30 pcs

**CHASIL21**

Ø 20 mm - 99 pcs

**CHASIL26**

Ø 62,5 mm - 12 pcs



**STAR**

**CHASIL29**

Ø 26 mm - 60 pcs

**CHASIL30**

Ø 34 mm - 42 pcs



**RECTANGULAR**

**CHASIL19**

32x120 mm - 12 pcs



**SPOT**

**CHASIL32**

60x63 mm - 16 pcs



**LEAF**

**CHASIL22**

75x33 mm - 25 pcs



**FANTASY 10**

**CHASIL 10**

97x30 mm - 18 pcs



**DROP**

**CHASIL 1**

35x25 mm  
60 pcs



**LEAF**

**CHASIL 2**

35x33 mm  
48 pcs



**HEART**

**CHASIL 3**

35x25 mm  
48 pcs



**PUZZLE**

**CHASIL 5**

50x78 mm  
18 pcs



**FLOWER**

**CHASIL 8**

55x50 mm  
25 pcs

# CHOCO LIGHT

Stampi termoformati leggeri ed economici per realizzare soggetti e decorazioni.  
Light and economical thermoformed moulds to create subjects and decorations.



**20-1010**  
Prod. 6 petals  
105x50 h 25 mm

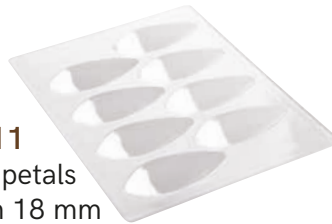

**20-1011**  
Prod. 8 petals  
80x35 h 18 mm

## LOTUS FLOWER

Kit composto da 1 stampo semisfera e 4 stampi petalo.  
Kit made up of 1 semisphere mould and 4 petal moulds.



**90-13064**



2 pcs  
Ø 50 h5



2 pcs  
Ø 40 h5



2 pcs  
Ø 32 h5



2 pcs  
55x50 h5



1 pcs  
70x40 h5



1 pcs  
80x45 h5



1 pcs  
55x30 h5



**90-13040**  
12 pcs - 35x60 h8



**90-13179**



2 pcs  
55x70 h5



2 pcs  
70x88 h5



1 pcs  
75x95 h8



**90-12816**



2 pcs - 50x20  
h8



2 pcs - 27x27  
h10



2 pcs - 40x35  
h10



2 pcs - 53x27  
h8



2 pcs - Ø 42 h8



2 pcs - 52x27  
h8



2 pcs - 35x40  
h8



**90-P9645**



10 pcs  
80x35 h3mm



**90-14243**



1 pcs  
45x40 h5mm



**90-P9661**



13 pcs  
50x25 h3mm



**90-P9662**



14 pcs  
50x25 h3mm



**90-1000**



1 pcs  
210x64 mm



**90-15303**



12 pcs  
42x19 h6mm

# 3D OBJECTS





# Magnetic 3D



Stampi tematici ad alta produttività in policarbonato con calamite per unire le due metà e realizzare in modo facile e preciso soggetti 3D in cioccolato.

High productivity thematic polycarbonate moulds with magnets to join the two halves and easily and precisely produce 3D chocolate subjects.

Polycarbonate moulds 275 x 175 mm with magnets

## HULA TREE

**20SR100**

ø 110 h 152 mm  
Prod. 2 pcs ~ 200 gr



## RUDOLPH

**20SR101**

88 x 56 h 120 mm  
Prod. 2 pcs ~ 70 gr



# Magnetic 3D

Polycarbonate moulds 275 x 175 mm with magnets



## SIR TOY

**20SR102**

53 x 44 h 120 mm  
Prod. 4 pcs ~ 35 gr



## DIAMANTINE

**20SR103**

ø 62 h 72 mm  
Prod. 6 pcs ~ 50 gr





Polycarbonate moulds 275 x 175 mm with magnets



## CURVY REINDEER

**20-C1002**

46 x 45 h 100 mm

Prod. 4 pcs ~ 68 gr

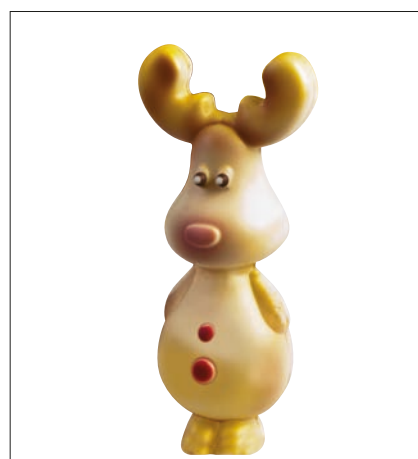

## REINDEER

**20-C1001**

43 x 43 h 120 mm

Prod. 4 pcs ~ 65 gr



## TREE

**20-C1000**

Ø 58 h 100 mm

Prod. 5 pcs ~ 100 gr



## SANTA & SNOWMAN

**20-C1010**

Santa Claus: ø 46 h79 mm

Snowman: 42 x 46 h72 mm

Prod. 4+4 pcs



# Diamond XMAS

Polycarbonate moulds 275 x 175 mm

La tradizione si trasforma in modernità grazie agli stampi in policarbonato per soggetti natalizi in versione diamantata.

Tradition turn into modernity thanks to the polycarbonate moulds for Christmas subjects in the diamond version.



TEDDY

**MA3014**

97 x 64 h 130 mm - Prod. 1 pcs - 110 gr



SANTA

**MA3013**

68 x 61 h 130 mm - Prod. 2 pcs ~ 120 gr



TREE

**MA3012**

Ø 104 h 180 mm - Prod. 1 pc ~ 160 gr

# XMAS objects

Polycarbonate moulds 275 x 175 mm



## SANTA

**MA3008**

Ø 70 h 120 mm ~ 55 gr  
Prod. 2 pcs



## TREESMAS

**MA3009**

Ø 75 h 120 mm ~ 45 gr  
Prod. 2 pcs



## BOTTLE

**MA3010**

Ø 65,4 h 220 mm  
tappo/closer ø 26,8 mm  
120 gr - Prod. 1 pc



## SMALL BOTTLE

**MA3011**

60,2 x 20,6 h 15,8 mm - 12 gr  
Prod. 18 pcs



# XMAS trees

Thermoformed moulds 275 x 175 mm

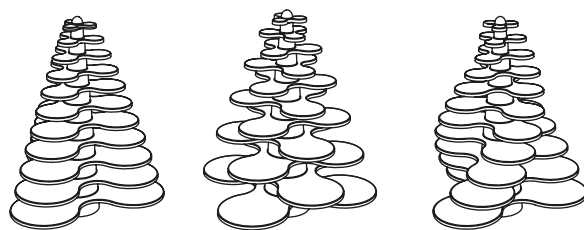

## MODULAR TREES

**20CT01**

Ø 150 h 180mm ~290 gr

4 Moulds - Prod. 2 pcs



## BIG TREE

**20CO02**

Ø 123 h 205mm

~300gr - Prod. 2 pcs

## SMALL TREE

**20CO01**

Ø 83 h 140mm

~140gr - Prod. 4 pcs

Stampi cono in plastica termoformata per realizzare alberi o pièce in cioccolato.

Thermoformed plastic moulds to make Christmas trees or chocolate pièce.

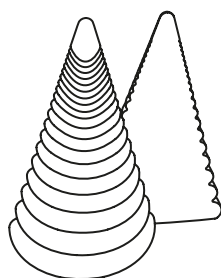

**20A3D01**  
Ø 112 h180 mm  
~170gr  
4 Moulds  
Prod. 2 pcs

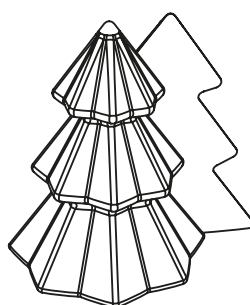

**20A3D02**  
Ø 95 h120 mm  
~100gr  
4 Moulds  
Prod. 4 pcs



# SWEET

## Christmas



Iconici soggetti 3D che rappresentano una golosa idea regalo da donare in occasione delle feste a parenti ed amici.

Iconic 3D subjects that represent a delicious gift idea to donate to relatives and friends during the holidays.

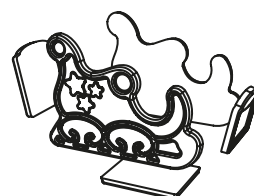

**Christmas Sledge**

**20SL01**

Thermoformed plastic  
140x70 h 100mm ~140 gr  
2 Moulds - Prod. 2 pcs

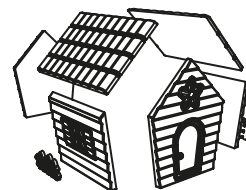

**Sweet Home**

**20HO01**

Thermoformed plastic  
108x116 h 118mm ~280 gr  
4 Moulds - Prod. 2 pcs



**Chocolate Gift**

**20PR01**

Thermoformed plastic  
80x80 h 69mm ~80 gr  
2 Moulds - Prod. 2 pcs

**Chocolate gift  
(Praline)**

**MA1991**

Polycarbonate mould  
26x26 h 20mm ~11gr  
Prod. 28 pcs

# *Kmas* PUZZLE

Thermoformed Plastic Moulds

Pratico kit in plastica termoformata ideale per la creazione veloce di 3 differenti soggetti 2D tematici.

Practical thermoformed plastic kit ideal for the quick creation of 3 different 2D thematic subjects.



## 20BC100

- 1) 95x9 h 147mm ~80 gr
- 2) 103x9 h 150mm ~80 gr
- 3) 100x9 h 123mm ~80 gr

# SEMISPHERES & Decorations

**Polycarbonate moulds**  
275x175 mm



**MA5000**  
24 half spheres  
Ø 30mm

**MA5003**  
45 half spheres  
Ø 20mm

**MA5004**  
15 half spheres  
Ø 40mm

**MA5001**  
8 half spheres  
Ø 50mm

**MA5005**  
6 half spheres  
Ø 60mm

**MA5007**  
28 half spheres  
Ø 25mm

**MA5008**  
15 half spheres  
Ø 35mm

**MA5009**  
12 half spheres  
Ø 45mm

**MA5010**  
6 half spheres  
Ø 55mm

**MA5006**  
4 half spheres  
Ø 80mm

**MA5002**  
2 half spheres  
Ø 100mm

**Thermoformed Moulds**



**Kit 6 Stampi - Moulds**  
**20SF001**  
Ø 100 mm - prod 1 pc  
Ø 130 mm - prod 1 pc  
Ø 140 mm - prod 1 pc  
Ø 150 mm - prod 1 pc  
Ø 175 mm - prod 1 pc  
Ø 200 mm - prod 1 pc

**Kit 4 Stampi - Moulds**  
**20SF002**  
Ø 50 mm - prod 6 pcs  
Ø 65 mm - prod 4 pcs  
Ø 75 mm - prod 4 pcs  
Ø 90 mm - prod 2 pcs

**Fiocchi di Neve**  
**Snowflakes**



**20-D029**  
Polycarbonate mould  
14 pcs Ø 30 h 4mm ~1gr  
12 pcs Ø 40 h 4mm ~2gr



# XMAS

## Baubles



**20SF003**  
Ø 60mm ~40 gr



**20SF004**  
Ø 60mm ~40 gr



**20SF005**  
Ø 60mm ~40 gr



**20SF006**  
Ø 60mm ~40 gr



**20SF007**  
Ø 60mm ~39 gr



**20SF008**  
62x69mm ~26 gr



Thermoformed Plastic Moulds  
Prod. 6 half baubles each

# 3D Xmas

Stampi in plastica rigida termoformata completi di molle per realizzare soggetti tematici tridimensionali.  
Thermoformed plastic moulds complete with springs to create hollow chocolate figures.

Thermoformed plastic moulds with springs



**MAC411S**  
**Princess** - 1 pc 72x72 h125mm



**MAC407S**  
**Toy Soldier** - 1 pc 40x34 h150mm



**MAC140S**  
**Santa Claus with fawn** - h180mm



**MAC409S**  
**Tender bear** - 67x54 h105mm ~90gr



**MAC408S**  
**Surprise bear** - 63x54 h101mm ~90gr



**MAC170S**  
**Santa Claus with teddy bear** - h168mm



**MAC310S**  
**Happy Snowman** - h100mm (2 figures)



**Snowman**  
**MAC320S** - h114mm (3 figures)  
**MAC321S** - h150mm



**MAC281S**  
**Santa Claus bear** - h180mm



**MAC412S**  
**Pandoro** - Ø 92 h 85mm ~80 gr



**MAC413S**  
**Panettone** - Ø 77 h 85mm ~80 gr



**Angel with Candle**  
**MAC000S** - h80mm (3 figures)  
**MAC001S** - h125mm (2 figures)



**MAC421S**  
**Big Boot** - h135mm



# CHOCO

---

*Light*

Stampi termoformati per realizzare soggetti e decorazioni di cioccolato.

Thermoformed mould for chocolate figures and decorations.



**90-4108**



4 pcs  
 Ø 30 h8

4 pcs  
 35x25 h8

4 pcs  
 Ø 35 h8

4 pcs  
 35x26 h8



**90-4109**



4 pcs  
 50x30 h6

4 pcs  
 48x25 h6

4 pcs  
 48x30 h6

4 pcs  
 45x30 h6

# LET'S PLAY

Thermoformed plastic moulds



**Chess Game**  
**20CG01**  
Ø 25/35 h 40/80 mm  
4 Moulds - Prod. 20 mix pcs ~11/36 gr

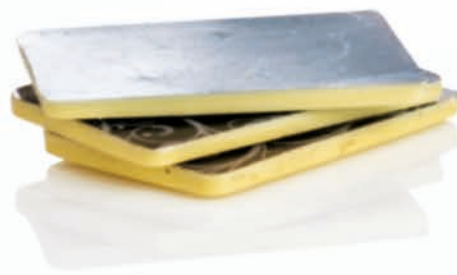
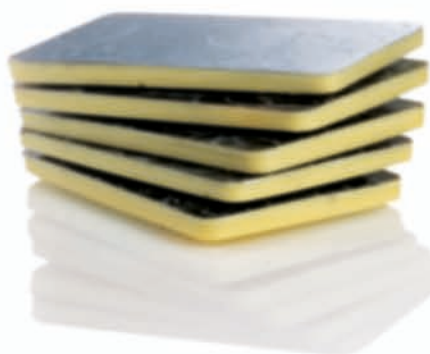

**Playing Cards**  
**20PC01**  
55x90 h 5 mm  
4 Moulds - Prod. 16 pcs ~55gr

Chocolate

# PER LUI FOR HIM

Thermoformed plastic moulds

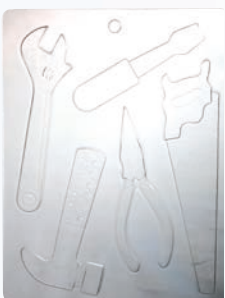

**Working Tools**  
**20WT01**  
190x50 / 115x20 mm  
4 Moulds - Prod. 20 mix pcs ~20/50 gr

# FASHION & STYLE

Thermoformed plastic moulds



**Mr Chocolate**  
**200B01**

**moustache:** 117x30 h15 mm  
**glasses:** 140x50 h 10 mm  
1+1 Moulds  
Prod. 4+4 pcs ~22gr



**Mr Cigar**  
**20SI01**

125 - Ø 20 mm  
2 Moulds  
Prod. 8 pcs ~40gr

Chocolate

# PER LUI FOR HIM

Thermoformed plastic moulds



**Soccer Ball  
MAC323S**

Ø 120 mm

1 Thermoformed plastic  
mould with springs



**Football Boot  
MAC322S**

195x60 h 80 mm

1 Thermoformed plastic  
mould with springs



**Mr. Papillon**

**20PP01**

120x52 h13mm

4 Moulds - Prod. 12 pcs ~55gr

# PER LEI FOR HER



**Eau de Chocolat**  
**20PA01**  
Thermoformed plastic  
60x31 h92mm ~90gr  
4 Moulds - Prod. 4 pcs



**My Sweet Bag**  
**20BA01**  
Thermoformed plastic  
119x52 h126 ~190gr  
2 Moulds - Prod. 2 pcs



# FASHION & STYLE



**Lady shoe BIG**  
**MAC326S**  
Thermoformed plastic  
mould with springs  
220x85 h165 mm  
Prod. 1 pcs ~375 gr



**Lady shoe SMALL**  
**MAC330**  
Polycarbonate mould  
with magnets  
160x70 h120 mm  
Prod. 1 pcs ~120 gr



# CHOCO MACARON

Stampo in silicone per realizzare splendide praline a forma di macaron.  
Silicone mould to create wonderful macaron pralines.



Gusci macaron e vassoio  
Macarons shells and tray

**30SMT01**

prod. 24 gusci / shells  
Soggetti/Subjects: Ø 33 h12mm  
Vassoio - Tray: 320x195mm  
Silicone mould

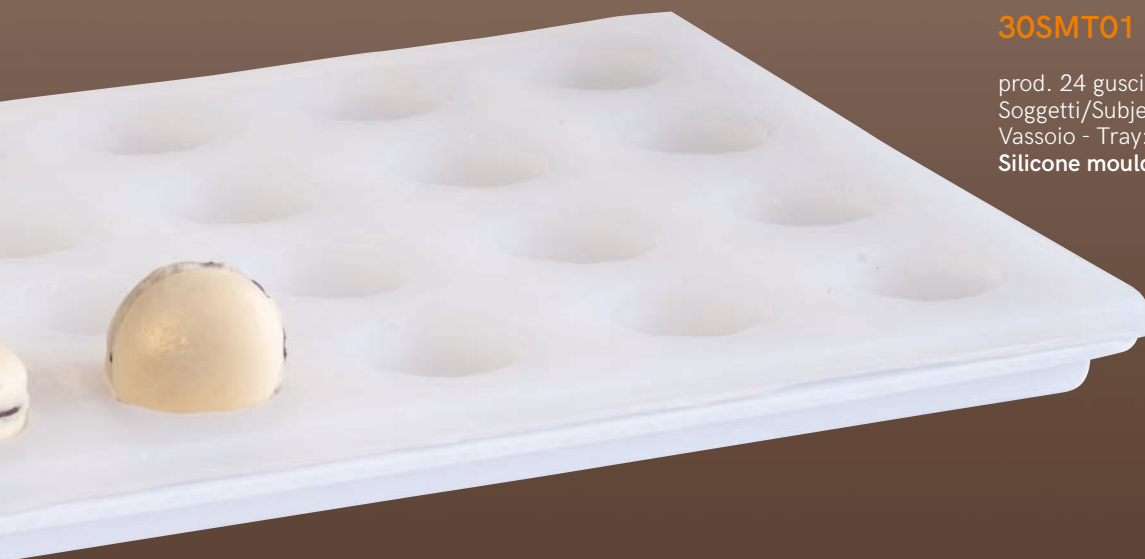

## OLD STYLE

Stampi 3D in silicone per realizzare realistici soggetti in cioccolato o isomalto.  
3D silicone moulds to create realistic figures in chocolate or isomalt.

*Silicone*  
Idea  
sweet creation



Scooter vintage  
Vintage scooter  
**30SM071**  
80x50 h75mm  
Silicone mould

# Easter EGGS

Sono in polycarbonato di alta qualità gli stampi per Uova in cioccolato proposti per la prossima Pasqua. Che sia il modello Happy Easter o l'uovo Crack, il risultato è un prodotto di grande effetto realizzabile facilmente.

The moulds for chocolate eggs of this Easter are made of high quality polycarbonate. Whether it is the Happy Easter model or the Crack egg, the result is a product of great effect made easily.

Polycarbonate moulds with magnets 275 x 175 mm





## HAPPY EASTER

**20SR022**

ø 156 x h 228 mm

Prod. 1 pcs ~ 330 gr

per la base è stato usato lo stampo 20-CU001

mould 20-CU001 was used for the base

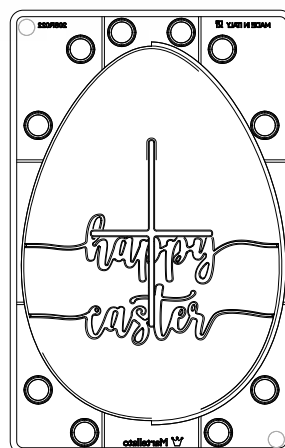

# Easter EGGS

Polycarbonate moulds 275 x 175 mm with magnets



## CRACK

**20SR021**

ø 100 x h 150 mm

Prod. 2 pcs ~ 160 gr

per la base è stato usato lo stampo 20-CU001

mould 20-CU001 was used for the base

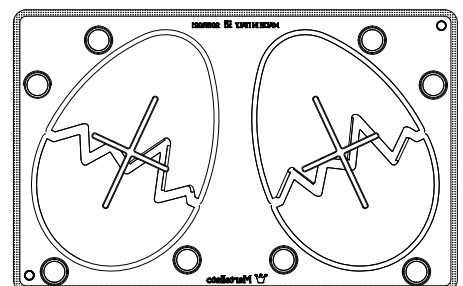



## SUAVE

### 20SR020

ø 113 x h 150 mm

Prod. 2 pcs ~ 220 gr

per la base è stato usato lo stampo 20-CU001

mould 20-CU001 was used for the base

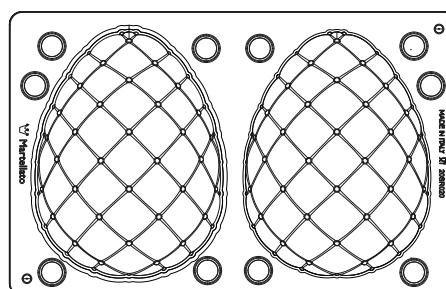

Easter

Polycarbonate moulds 275 x 175 mm

# EGGS

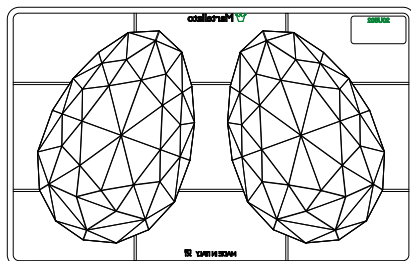

## DIAMOND

**20U502**

Ø 99 h 150 mm

Prod. 1 pc ~ 210 gr

base non inclusa / base not included

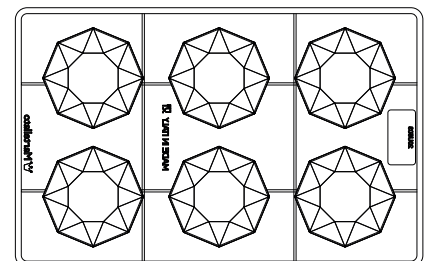

## BASE

**20U503**

68 x 68 h 5,5 mm

Prod. 6 pcs ~ 16 gr

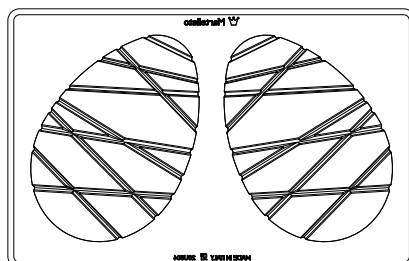

## BOND

**20U504**

Ø 101 h 150 mm

Prod. 1 pc ~ 210 gr

base non inclusa / base not included

# Easter EGGS

Polycarbonate moulds 275 x 175 mm

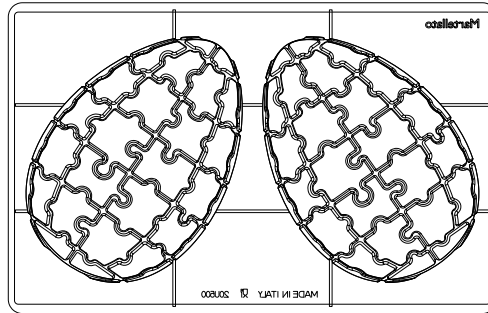

## PUZZLE

**20U500**

ø 105 h 150 mm

Prod. 1 pc ~ 210 gr

base non inclusa / base not included

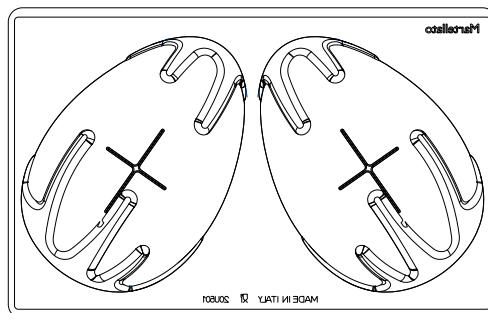

## DRIP

**20U501**

ø 100 h 150 mm

Prod. 1 pc ~ 210 gr

base non inclusa / base not included

# Easter EGGS

Thermoformed moulds

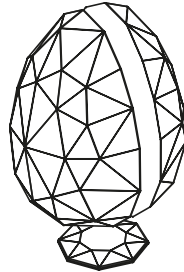

## DIAMOND

**20U3D07**

**Thermoformed plastic**

Ø 120 h 185 mm

Prod. 2 pcs ~ 280 gr

base inclusa / base included



## GLOBE

**20U3D08**

**Thermoformed plastic**

Ø 125 h 185 mm

Prod. 2 pcs ~ 280 gr

base inclusa / base included

# Easter EGGS

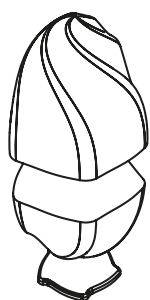

## WAVE

**20U3D02**

Ø 115 h 185 mm  
Prod. 2 pcs ~ 320 gr  
base inclusa / base included

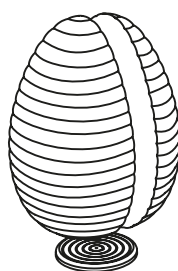

## HONEY

**20U3D04**

Ø 122 h 185 mm  
Prod. 2 pcs ~ 270 gr  
base inclusa / base included

Chocolate

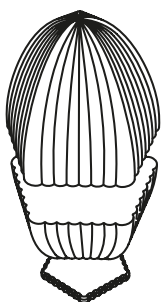

## PENTA

**20U3D03**

Ø 120 h 185 mm

Prod. 2 pcs ~ 300 gr

base inclusa / base included



## CURVY

**20U3D05**

Ø 115 h 185 mm

Prod. 2 pcs ~ 310 gr

base inclusa / base included

# Easter EGGS

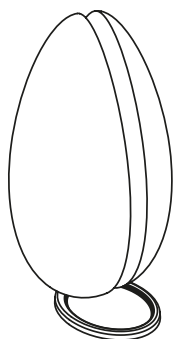

## STRETCH

**20U3D01**

Ø 110 h 220 mm

Prod. 2 pcs ~ 230 gr

base inclusa / base included

Chocolate

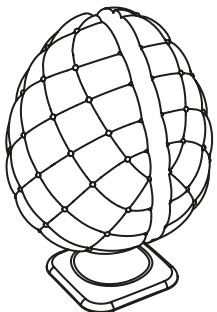

## CAPITONNÉ

**20U3D06**

Ø 115 h 155 mm

Prod. 2 pcs ~ 230 gr

base inclusa / base included



# UOVA LISCE / SMOOTH EGGS

Polycarbonate moulds with magnets 275 x 175 mm



## EGG 15

**20SR001**

ø 104 h 150 mm

Prod. 2 pcs ~ 230 gr

base non inclusa / base not included



## EGG 17

**20SR003**

ø 120 h 175 mm

Prod. 1 pcs ~ 260 gr

base non inclusa / base not included

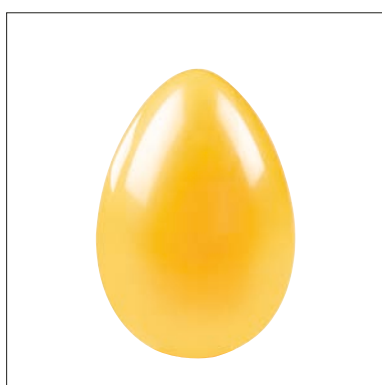

## EGG 20

**20SR002**

ø 141 x h 204 mm

Prod. 1 pcs ~ 380 gr

base non inclusa / base not included



## EGG 23

**20SR004**

ø 160 h 230 mm

Prod. 1 pcs ~ 430 gr

base non inclusa / base not included



Created by  
**Maurizio Frau**

# UOVA LISCE / SMOOTH EGGS

Polycarbonate moulds 275 x 175 mm

base non inclusa / base not included

## 7gr

**20U032N**

22 x 32 mm

Prod. 16 uova/egg

Peso uovo senza camicia/egg weight  
without shell ~ 9 gr

## 25gr

**20U064N**

44 x 64 mm

Prod. 5 uova/egg

Peso uovo/egg weight ~ 30 gr  
Spessore camicia/shell thickness: 3 mm

## 70gr

**20U105N**

72 x 105 mm

Prod. 2 uova/egg

Peso uovo/egg weight ~ 50 gr  
Spessore camicia/shell thickness: 3,5 mm

## 150gr

**20U130N**

90 x 130 mm

Prod. 1 uovo/egg

Peso uovo/egg weight ~ 100 gr  
Spessore camicia/shell thickness: 3,5 mm

## 230gr

**20U150N**

104 x 150 mm

Prod. 1 uovo/egg

Peso uovo/egg weight ~ 150 gr  
Spessore camicia/shell thickness: 3,5 mm

## 260gr

**20U175N**

121 x 175 mm

Prod. 1 mezzo/half

Peso uovo intero/complete egg weight ~ 230 gr  
Spessore camicia/shell thickness: 3,5 mm

## 380gr

**20U204N**

141 x 204 mm

Prod. 1 mezzo/half

Peso uovo intero/complete egg weight ~ 320 gr  
Spessore camicia/shell thickness: 4 mm

## 430gr

**20U227N**

157 x 227 mm

Prod. 1 mezzo/half

Peso uovo intero/complete egg weight ~ 450 gr  
Spessore camicia/shell thickness: 4 mm

Polycarbonate mould

200 x 365 h 22 mm

Polycarbonate mould

275 x 365 h 22 mm

## 500gr

**20U258**

258 x 175 mm

Prod. 1 mezzi/half

Peso uovo intero/complete egg weight ~ 540 gr  
Spessore camicia/shell thickness: 4 mm

## 850gr

**20U320**

320 x 210 mm

Prod. 1 mezzi/half

Peso uovo intero/complete egg weight ~ 630 gr  
Spessore camicia/shell thickness: 4 mm



*Light Half*  
**EGGS**



# UOVA LISCE / SMOOTH EGGS

**Stampo in plastica termoformata.** Base non inclusa.  
**Thermoformed plastic mould.** Base not included.



**90-2026**

25 x 35 h 12 mm  
18 pcs



**90-2008**

36 x 23 h 12 mm  
18 pcs



**90-2010**

40 x 31 h 17 mm  
14 pcs



**SM 1000**

80 x 60 h 25 mm  
4 pcs



**SM 2000**

110 x 80 h 40 mm  
2 pcs



**SM 2300**

112 x 83 h 44 mm  
1 pc x 2 moulds



**SM 4000**

220 x 160 h 85 mm  
1 pcs

**SM 2500**

125 x 94 h 44 mm  
2 pcs

**SM 3500**

154 x 110 h 55 mm  
2 pcs

**Stampo in plastica rigida.** Base non inclusa.  
**Rigid plastic mould.** Base not included.

~Kg	Misure mm	Code
0,5 - 1	250 x 170	<b>SUT25X17</b>
0,8 - 1,2	280 x 185	<b>SUT28X18</b>
1,5 - 2	325 x 240	<b>SUT34X25</b>
2 - 2,5	390 x 265	<b>SUT40X27</b>
2,5 - 3,5	435 x 310	<b>SUT45X32</b>
4 - 6	520 x 350	<b>SUT54X36</b>
6 - 8	620 x 420	<b>SUT64X43</b>
8 - 10	740 x 490	<b>SUT75X50</b>



**Stampo in plastica termoformata** per la realizzazione di uova di cioccolato. Base non inclusa.  
**Thermoformed plastic mould** to realize chocolate eggs. Base not included.

## CRACK HALF EGG



**90-2009**  
 39 x 25 h 13 mm  
 14 pcs



**90-2353**  
 64 x 44 h 26 mm  
 6 pcs



**90-2354**  
 83 x 54 h 24 mm  
 4 pcs



2 moulds  
**90-2355**  
 96 x 70 h 40 mm  
 2 pcs



2 moulds  
**90-2356**  
 140 x 100 h 49 mm  
 1 pcs



## EGGS HOLDERS

Per realizzare supporti di cioccolato  
 To create chocolate holders



**20-CU001**  
**Set 3 thermoformed moulds**  
 36,5 x 36,5 h 9 mm - 12 pcs  
 40,5 x 40,5 h 12 mm - 9 pcs  
 52,7 x 52,7 h 12 mm - 6 pcs

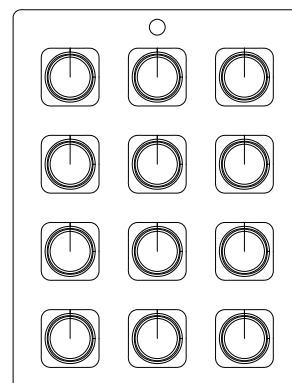

# Sectioned EGGS



Stampo in plastica termoformata.  
Thermoformed plastic mould.



**20-U1010**  
h 110 mm ~100 gr  
Thermoformed mould



**20-U1011**  
h1 80 mm ~250 gr  
Thermoformed mould

# PUZZLE EGGS



## 20UB100

Thermoformed plastic

Pack 3 models

- 1) 107 x 82 h 158 mm ~160 gr
  - 2) 110 x 58 h 165 mm ~160 gr
  - 3) 104 x 52 h 150 mm ~140 gr
- base inclusa / base included

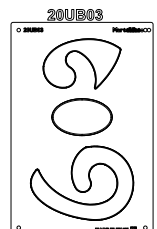
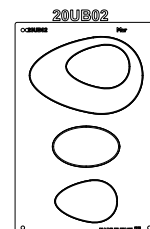
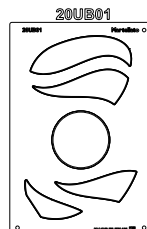

# Origami Easter



**20OR001**

**Thermoformed plastic**

Pack 3 models

Chick: 113 x 42 h 132 mm ~100 gr

Sheep: 100 x 45 h 100 mm ~90 gr

Bunny: 76 x 42 h 142 mm ~60 gr

base inclusa / base included

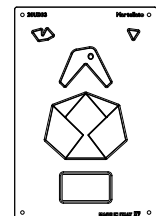
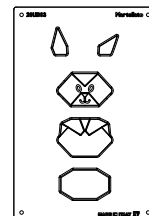
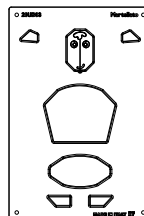

# Easter objects

Polycarbonate mould 275 x 175 mm



ROGER

**MA3016**

78 x 73 x h 150 mm

Prod. 1 pcs ~ 130 gr



Polycarbonate moulds with magnets 275 x 175 mm



## ROOSTER

20-C1955

100 x 160 h 126 mm  
~ 80 gr - Prod.2 pcs



## HEN

20-C1956

94 x 108 h 106 mm  
~ 75 gr - Prod.4 pcs



## CHICK

20-C1957

65 x 84 h 80 mm  
~ 45 gr - Prod.6 pcs

# CHOCO

## 3D

Stampi in plastica termoformata con molle per soggetti di cioccolato con corpo cavo.  
Thermoformed plastic mould with springs for chocolate figures.



SHEEP

MAC603S

140 x 120 h 190mm  
~310 gr



CHICK

MAC602S

160 x 120 h 210mm  
~460 gr



RABBIT

MAC604S

120 x 120 h 220mm  
~480 gr



CHICKEN

MAC612S

70 x 70 h 130mm  
~110 gr



DUCK

MAC611S

70 x 70 h 120mm  
~110 gr



LITTLE BUNNY

MAC614S

Ø 60 h 140mm  
~85 gr



BUNNY

MAC613S

Ø 80 h 120mm  
~110 gr



## MS COCODÉ

**MAC615S**  
 108 x 75 h 120 mm  
 ~90 gr

## MR. BUNNY

**MAC616S**  
 90 x 60 h 152 mm  
 ~100 gr



**Stampi in plastica rigida termoformata con molle** per realizzare soggetti tridimensionali.  
**Thermoformed plastic mould with springs** to easily realize hollow chocolate figures.



## NICE CHICKEN

MAC800S

h 160 mm (2 figures)

MAC801S

h 205 mm



## SMALL CHICKEN

MAC822S

h 110 mm

MAC823S

h 160 mm



## BABY CHICK

MAC870S

h 110 mm (3 figures)



## BABY GOOSE

MAC880S

h 145 mm



## SMALL BELL

MAC950S

h 110 mm



## BUNNY

MAC661S

h 140 mm



## BABY BUNNY

MAC620S

h 180 mm



## HUG IN EGG

MAC720S

h 170 mm (2 figures)



## BUNNY IN LOVE

MAC630S

h 235 mm

Chocolate

# ANIMATED EGGS

Kit stampi componenti in **plastica termoformata** per realizzare soggetti 3D  
**Thermoformed plastic** components mould kit to realize 3D objects

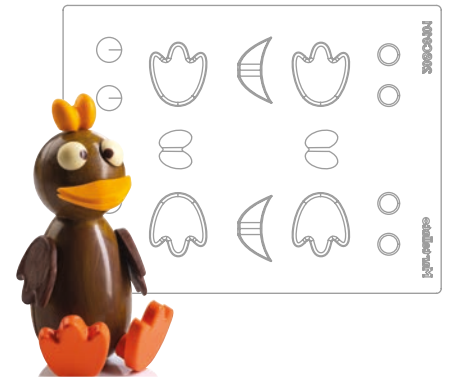
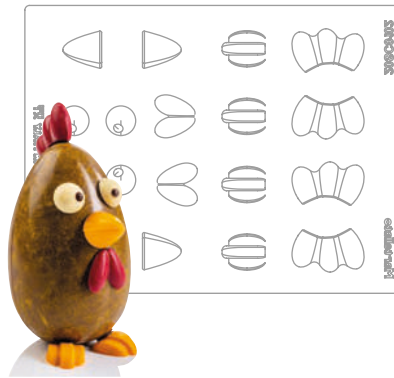

## 20SC01

Pack 3 pezzi per soggetti differenti. Non inclusi uova e sfere per corpo.  
 Pack 3 pcs for different figures. Eggs and sphere for body not included.

# CHOCO

## Light

**Stampi in plastica termoformata** per realizzare soggetti e decorazioni di cioccolato.  
**Thermoformed plastic moulds** to create chocolate figures and decorations.



90-2102



3 pcs  
43x40 h12



4 pcs  
40x35 h11



4 pcs  
40x35 h17



3 pcs  
48x35 h8



90-2316  
79x58h12 mm  
2 pcs



90-2346  
150x64h25 mm  
1 pcs



# Halloween figures

Stampi in plastica termoformata con molle per soggetti di cioccolato con corpo cavo.  
Thermoformed plastic mould with springs for chocolate figures.



**BIG 3D PUMPKIN**

**MAC325S**  
140 x 140 h 150 mm



**SMALL 3D PUMPKIN**

**MAC324S**  
52 x 54 h 132 mm ~ 140 gr

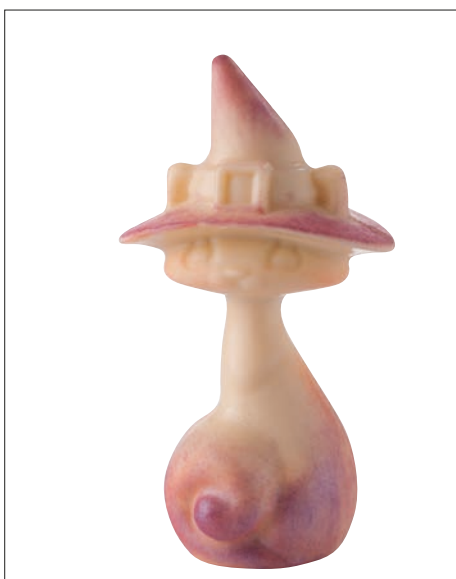

**BLACK CAT**

**MAC405S**  
57 x 39 x h 102 mm ~ 50 gr



**MR PUMPKIN**

**MAC406S**  
39 x 42 x h 102 mm ~ 40 gr



# PERFORMANCE

*designed for Chocolate Machines*

PERFORMANCE, diverse tipologie di stampi, tutte con un denominatore comune: elevate performance produttive ottenute grazie all'interazione con le macchine per il cioccolato.

Stampi in policarbonato con caratteristiche che li rendono adatti a tutte le macchine presenti sul mercato e consentono un automatismo produttivo, pur mantenendo l'esclusività della produzione artigianale.

**Performance comprende le linee One Shot, per macchine dosatrici, e la linea Spinning, per macchine rotative.**

*PERFORMANCE, different moulds types, all with a common denominator: high production performance achieved through interaction with chocolate machines. Polycarbonate moulds with features that make them suitable for all machines on the market and provide production automation, while maintaining the exclusivity of artisan production.*

**Performance includes the One Shot line, for dosing machines, and the Spinning line, for rotating machines.**



WATCH THE VIDEO

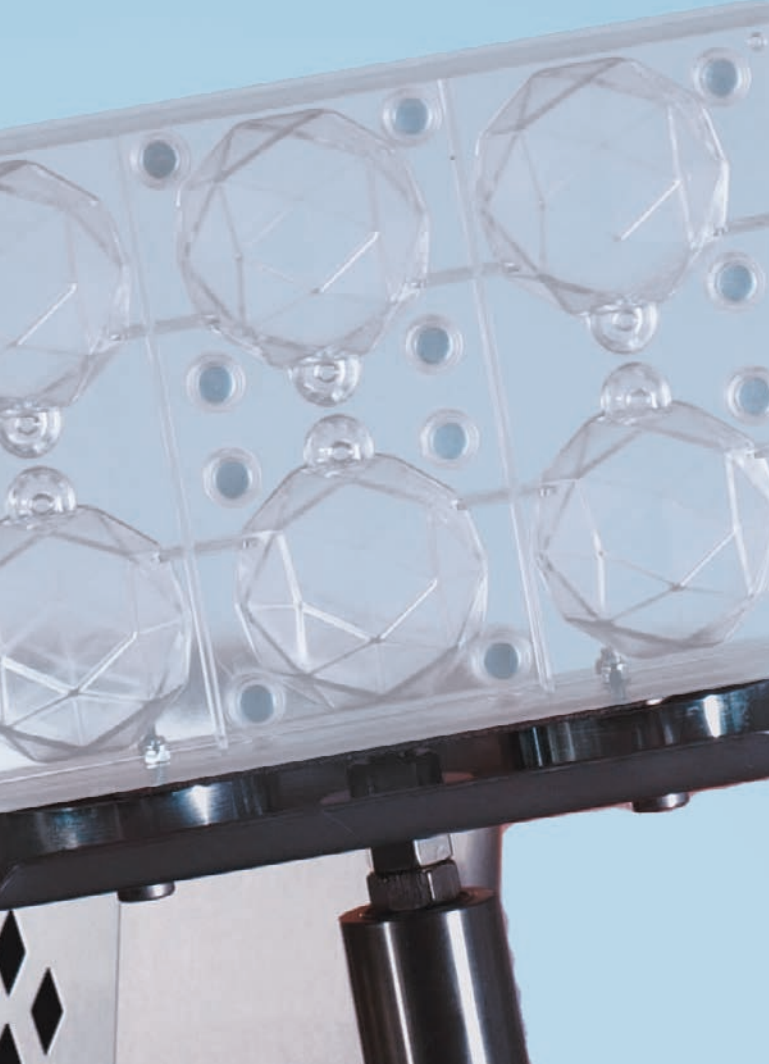

**SPINNING**  
MOULD

**Stampi per soggetti adatti all'uso sulle macchine rotative.**

**Moulds for subjects suitable for use on rotating machines.**



**[ONE SHOT]**

**Stampi per praline adatti all'uso con macchine dosatrici OneShot.**

**Moulds for pralines suitable for use with OneShot dosing machines.**



**Stampi per praline adatti all'uso con macchine dosatrici OneShot.**

**Moulds for pralines suitable for use with OneShot dosing machines.**

**Caratteristiche tecniche/Technical features**



Chiusura con magneti  
Magnetic closure

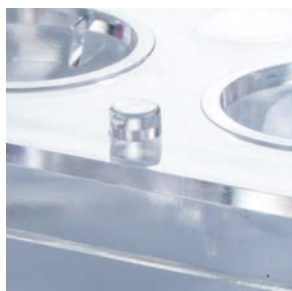

Pioli di centraggio  
Centring pegs



Sistema di incastro  
Interlocking system

# [ONE SHOT]

PER DOSATRICI SIMULTANEE  
FOR SIMULTANEOUS DISPENSING MACHINE

Polycarbonate moulds with magnets 275 x 175 mm



## TRUFFLE

**203D01**

Ø 26 h 24 mm

Prod. 28 pcs ~ 10 gr



## TRUFFLE 2

**203D02**

Ø 23 h 20,6 mm

Prod. 28 pcs ~ 7 gr



## HEART

**203D03**

30 x 28 h 19 mm

Prod. 28 pcs ~ 11 gr



## EGG

**203D04**

Ø 23,5 h 32 mm

Prod. 28 pcs ~ 10 gr



**Stampi per soggetti adatti all'uso sulle macchine rotative.**

**Moulds for subjects suitable for use on rotating machines.**

### Caratteristiche tecniche/Technical features



Chiusura con magneti  
Magnetic closure



Pioli di centraggio  
Centring pegs



Placca di metallo  
Metal plate



PER MACCHINE ROTATIVE  
FOR ROTATING MACHINE

Polycarbonate moulds with magnets 275 x 175 mm



**20SR001A**

ø 104 h 150 mm

Prod. 2 pcs ~ 230 gr

base non inclusa / base not included



**20SR003A**

ø 120 h 175 mm

Prod. 1 pcs ~ 260 gr

base non inclusa / base not included



**20SR002A**

ø 141 x h 204 mm

Prod. 1 pcs ~ 380 gr

base non inclusa / base not included



**20SR004A**

ø 160 h 230 mm

Prod. 1 pcs ~ 430 gr

base non inclusa / base not included

Polycarbonate moulds with magnets 275 x 175 mm

## HAPPY EASTER

### 20SR022A

ø 156 x h 228 mm - Prod. 1 pcs ~ 330 gr  
base non inclusa / base not included



## CRACK

### 20SR021A

ø 100 x h 150 mm - Prod. 2 pcs ~ 160 gr  
base non inclusa / base not included



## SUAVE

### 20SR020A

ø 113 x h 150 mm - Prod. 2 pcs ~ 220 gr  
base non inclusa / base not included





CON PLACCA PER MACCHINE ROTATIVE / WITH METAL PLATE FOR ROTATING MACHINES

**SPINNING**  
MOULD

PER MACCHINE ROTATIVE  
FOR ROTATING MACHINE



**PERFORMANCE**

*designed for Chocolate Machines*



Polycarbonate moulds with  
magnets 275 x 175 mm

**TREE**

**20SR100A**

ø 110 x h 152 mm  
Prod. 2 pcs ~ 200 gr



Chocolate

Polycarbonate moulds with magnets 275 x 175 mm

## REINDEER

**20SR101A**

88 x 56 h 120 mm  
Prod. 2 pcs ~ 70 gr



## TOY

**20SR102A**

53 x 44 h 120 mm  
Prod. 4 pcs ~ 65 gr



## DIAMOND BALL

**20SR103A**

ø 62 h 72 mm  
Prod. 6 pcs ~ 50 gr



# Wedding Time

Tappeti e stampi 3D in silicone per realizzare topper e piece in **cioccolato** o **isomalto** che serviranno a decorare wedding cake o altre creazioni.

Mats and 3D silicone moulds to prepare **chocolate** or **isomalt** toppers and pieces that will be used to decorate wedding cakes or other creations.





## WEDDING MAT 2

**30SMTP02**

210x85 h 250mm

Spessore - Thickness: 9mm

Tappeto - Mat: 300x400mm



## WEDDING MAT 3

**30SMTP03**

250x85 h 285 mm

Spessore - Thickness: 9mm

Tappeto - Mat: 300x400mm



## WEDDING MAT 1

**30SMTP01**

260x85 h 310mm

Spessore - Thickness: 9mm

Tappeto - Mat: 300x400mm

vassoio di sostegno in plastica bianca

white plastic support tray

*Silicone*  
**Idea**  
sweet creation

# New Born

Tappeti e stampi 3D in silicone per realizzare topper e piece in **cioccolato** o **isomalto** che serviranno a decorare torte o creare originali bomboniere.

Mats and 3D silicone moulds to prepare **chocolate** or **isomalt** toppers and pieces ideal to decorate cakes or realize original party favours.



## 30SMTP04

Misure - Size: 300x400mm  
Spessore - Thickness: 9mm

Tappeti in silicone per realizzare topper e decorazioni.  
Silicone mat to produce toppers and decorations.

# Holy Sacraments

Tappeti e stampi 3D in silicone per realizzare topper e piece in **cioccolato** o **isomalto** che serviranno a decorare torte o creare originali bomboniere.

Mats and 3D silicone moulds to prepare **chocolate** or **isomalt** toppers and pieces ideal to decorate cakes or realize original party favours.



165x90 h 140mm



170x90 h 143mm



175x90 h 145mm



## COMMUNION AND CONFIRMATION

**30SMTP05**

Misure - Size: 300x400mm

Spessore - Thickness: 9mm

# LOLLIPOP *Mania*

## Love

Thermoformed plastic



**20L004**

Thermoformed plastic  
68x65 h9 mm ~ 34 gr  
Prod. 8 pcs



## Silicone

**30SML003**

Silicone mould  
Tray included: 395x143mm  
Prod. 5 pcs



**Cupido**  
Cupid  
65x80mm



**Innamorati**  
Loving couple  
73x80mm



**Bambina**  
Girl  
65x85mm



**Innamorato**  
Boy in love  
60x85mm



**Innamorata**  
Girl in love  
70x80mm

## Halloween

Thermoformed plastic



**Pumpkin & Skull Lollipops**  
**20L006**

Thermoformed plastic  
Prod. 8 pcs  
Zucca - Pumpkin:  
69x70 h9 mm ~ 33gr - 4 pcs  
Teschio - Skull:  
53x70 h9 mm ~ 32gr - 4 pcs



# Xmas

Thermoformed plastic

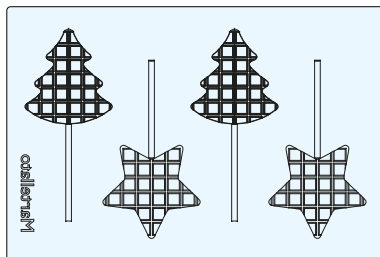

**Chocolate lollipop moulds**  
**20L005**

Thermoformed plastic - Prod. 8 pcs  
Albero - Tree: 70x76 h9 mm ~34 gr  
Stella - Star: 77x74 h9 mm ~31 gr



## Silicone



70x80mm

75x85mm

70x85mm

80x80mm

60x85mm

**Chocolate lollipop moulds**  
**30SML002**

Silicone mould - Prod.5 pcs  
Tray included: 395x143mm



**Chocolate lollipop moulds**  
**20-C024**

Rigid plastic mould -  
Prod.6 pcs  
60x70 mm ~30gr

# Choco à porter

## Thermoformed plastic

Funzionali e leggeri stampi in plastica termoformata, consentono di creare golosi lollipop per le merende dei più piccoli o i break dei giovani di ogni età.

Functional and lightweight thermoformed plastic moulds, they allow you to create delicious lollipops for snacks of children or breaks for young people of all ages.



**Ovale liscio**  
**Smooth Oval**

**20L008**

5+5 pcs ~22 gr  
43x57 h 9 mm

**Tondo liscio**  
**Smooth Rounded**

**20L007**

5+5 pcs ~25 gr  
Ø 50 h 9 mm

**Tondo tavoletta**  
**Round bar**

**20L002**

8 pcs ~30 gr  
Ø 60 h 9 mm

**Rettagonolare tavoletta**  
**Rectangular bar**

**20L003**

8 pcs ~30 gr  
50x75 h 9 mm

**Uovo tavoletta**  
**Egg bar**

**20L001**

8 pcs ~30 gr  
52x77 h 9 mm



# PLEXIGLASS DISPLAYS



**EL101**

Cap. 56 pcs  
345x280 h40 mm



**EL306**

Satinato - Satin  
Cap. 30 pcs  
295x70 h125 mm



**29003**

Cap. 20 lollipop  
270x180 h 145mm



**EL201**

Cap. 66 pcs  
450x240 h145 mm

# ACCESSORIES

**Sacchetti per lollipops**  
**Bags for lollipops**



**20S004**

80x120 mm  
200 pcs

**20S005**

90x130 mm  
200 pcs

# CHOCO TOOLS



# CHOCO TOOLS

Forchette in filo di acciaio inox con manico in plastica.  
Stainless steel wire forks with plastic handle.

## Single fork - Pack 25 pcs

Tipo Type	Codice Code
1	50CHOC01
2	50CHOC02
3	50CHOC03
4	50CHOC04
5	50CHOC05
6	50CHOC06
7	50CHOC07
8	50CHOC08
9	50CHOC09
10	50CHOC010



## Kit assortito - Mixed set 10 pcs

### CHOCOFORK

1 forchetta per tipo - 1 fork each type

## Texture decoro per cioccolato Artisan decor sheets

### MACL01

Pack 13 pcs - 360x340 mm

Kit fogli in plastica trasparente per la realizzazione di praline artigianali e decorazioni di cioccolato.

Transparent plastic sheets kit for handmade pralines and chocolate decorations.



# PACKAGING



## Bordo satinato - Satin glim boxes

Alveoli trasparenti - Transparent cavities  
31x26 h 10mm - pack 25 pcs

Misure Size mm	Alveoli Cavities	Codice Code
100x115 h23	6	MSC201
210x100 h23	12	MSC202



## Scatole trasparenti - Transparent boxes

Alveoli trasparenti - transparent cavities  
31x26 h 10mm - pack 25 pcs

Misure Size mm	Alveoli Cavities	Codice Code
160x40 h20	5	MSC001
110x100 h20	9	MSC002
220x65 h20	12	MSC003
160x150 h20	20	MSC004

## Mart Box: tagliato da te

Pratico sistema per realizzare il confezionamento perfetto per le tue creazioni, adattandolo ad ogni specifica esigenza. Mart Box è composto da una bobina in plastica trasparente lunga 15 mt che potrà facilmente essere tagliata nella misura desiderata e completata con coperchi double-face.

## Mart Box: cut by you

A practical system to realize the perfect packaging for your creations and to adapt it in any specific requirement. Mart Box is composed of a 15 m long transparent plastic reel that can be easily cut up into desired lengths and completed with double-face covers.



Metti in mostra il lato che preferisci: abbinata al tuo Mart Box il seguente coperchio double-face. Show the favourite side: match your Mart Box with the following double-face cover.

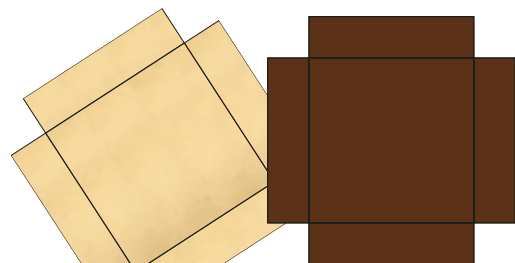

oro - marrone  
gold side - brown side

48x48mm  
22BOX48

60x60mm  
22BOX60

85x85mm  
22BOX85

Size mm	pcs	Code
48x48	100	22BOX48T4
60x60	100	22BOX60T4
85x85	100	22BOX85T4

Realizzato in materiale plastico termoresistente, con vasca e coperchio rimovibile in acciaio inox e sonda termica per la regolazione della temperatura del cioccolato. La scheda elettronica gestisce la resistenza interna e la rilevazione della temperatura del cioccolato tramite la sonda esterna per ottimizzare il raggiungimento del risultato richiesto e per consentire un più rapido e preciso scioglimento del cioccolato. Il pannello frontale fornisce suggerimenti per il temperaggio, regolabile manualmente o seguendo i 3 programmi differenti in base al tipo di cioccolato: bianco, al latte o fondente. Le indicazioni del display aiutano l'operatore a completare le fasi del temperaggio e del mantenimento del cioccolato.

# DigitalMeltinChoc

MADE IN ITALY

Made of heat-resistant plastic material, with a stainless steel tank and removable lid and a thermal probe for the regulation of the chocolate temperature. The electronic card manages the internal resistance and the chocolate temperature detection through the external probe to optimize the achievement of the required result and to allow a faster and more precise melting of the chocolate.

The front panel provides suggestions for tempering, adjustable manually or by following the 3 different programs according to the type of chocolate: white, milk or dark chocolate. The display indications help the operator to complete the tempering and chocolate maintenance phases.



**MCDA103**  
adatto per scioglitore  
9L e 13,7L

**KIT SUPPORTO STAMPO E PULISCI SPATOLA IN ACCIAIO INOX**  
STAINLESS STEEL MOULD SUPPORT AND SPATULA CLEANER

- **Temperatura costante ed omogenea**  
Constant and homogenous temperature
- **Vasca estraibile in acciaio inox**  
Removable stainless steel basin
- **Programmi selezionabili**  
Preset programs
- **Rapido scioglimento**  
Quick melting
- **Controllo digitale**  
Digital control
- **Display grafico**  
Graphic display
- **Sonda termica**  
Thermal probe
- **Indicatori sonori**  
Sound indicators



Watch the video in  
Martellato's YouTube channel.

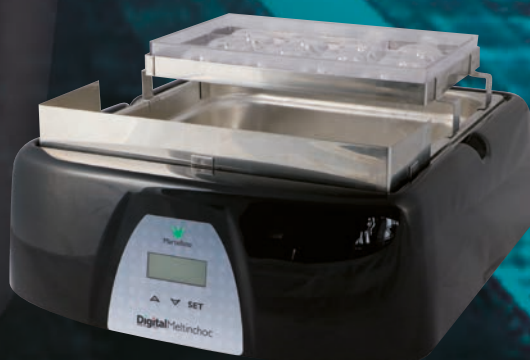

3,6 L

**MCD101**

24x40 h13,5cm

Vasca - Basin: 18x32,5 h10cm



6 L

**MCD102**

33x40 h13,5cm

Vasca - Basin: 26,5x32 h10cm



9 L

**MCD103**

39,5x45 h13,5cm

Vasca - Basin: 32x35,3 h10cm



13,7 L

**MCD104**

39,5x62 h13,5cm

Vasca - Basin: 32,5x53 h10cm



Su richiesta disponibili scioglitori con cablaggio  
GB / USA / GIAPPONE / AUSTRALIA / CINA.

UK / US / JAPAN / AUSTRALIA / CHINA  
wirings available upon request.

# Meltingchoc

MADE IN ITALY

## MELTINGCHOC ANALOGICI

I Meltingchoc sono degli strumenti indispensabili per la lavorazione del cioccolato. Precisione, design, semplicità e ingombro ridotto sono i principali vantaggi di questi dispositivi in grado di soddisfare anche i pasticceri più esigenti. Gli scioglitori a secco analogici sono dotati di una pratica **vasca in acciaio inox** removibile con scocca in plastica. Il termostato manuale permette di regolare e mantenere il cioccolato alla temperatura desiderata. Realizzati in materiale plastico termoresistente, gli scioglitori per cioccolato hanno capienze comprese tra 0,8 e 13 litri.

## ANALOGUE MELTINGCHOC

The Meltingchoc are essential tools for chocolate processing. Precision, design, ease of use and compactness are the main advantages of these devices, designed to meet the requirements of even the most demanding pastry chef. These dry heat analogue melters are equipped with a practical and removable **stainless steel tank** with plastic chassis. The manual thermostat allows you to adjust and maintain the chocolate at the desired temperature. Made with heat-resistant plastic, the chocolate melters can hold from 0,8 to 13 liters.



Scocca in resistente materiale plastico  
Shell made of durable plastic material

Termostato a regolazione manuale  
Manual regulation thermostat

## MONO



1,5 L

**MC105**

24x26 h13,5cm

Vasca - Basin: 14x15,5 h10cm



3,6 L

**MC101**

24x40 h13,5cm

Vasca - Basin: 18x32,5 h10cm



6 L

**MC102**

33x40 h13,5cm

Vasca - Basin: 26,5x32 h10cm



9 L

**MC103**

39,5x45 h13,5cm

Vasca - Basin: 32x35,3 h10cm



13,7 L

**MC104**

39,5x62 h13,5cm

Vasca - Basin: 32,5x53 h10cm

## MULTI



0,8x3 L

**MC107**

Misure - Size: 39,5x26,5 h13,5cm

Vasca - Basin: 8,3x15 h10cm

Mono Termostato - Mono-Thermostat



1,5x2 L

**MC108**

42x26 h13,5cm

Vasca - Basin: 14x15,5 h10cm

Multi Termostato - Multi-Thermostat



1,5x3 L

**MC100**

61x26 h13,5cm

Vasca - Basin: 14x15,5 h10cm

Multi Termostato - Multi-Thermostat



1,5x4 L

**MC106**

79x26 h13,5cm

Vasca - Basin: 14x15,5 h10cm

Multi Termostato - Multi-Thermostat

Su richiesta disponibili scioglitori con cablaggio GB / USA / GIAPPONE / AUSTRALIA / CINA.  
UK / US / JAPAN / AUSTRALIA / CHINA wirings available upon request.

# MiniMeltinChoc

MADE IN ITALY

Il **mini scioglitore a secco per cioccolato** è adatto sia in laboratorio per piccole produzioni di praline e soggetti, che in gelateria per la copertura di gelati e dessert su stecco. La capacità contenuta consente la lavorazione di piccole quantità senza sprechi e la **pratica vasca estraibile** garantisce una manutenzione facile e veloce. Il **design raffinato** e le **dimensioni ridotte** lo rendono perfetto per l'utilizzo anche direttamente sul bancone.

The **mini dry melter for chocolate** is suitable both in the laboratory for small productions of pralines and subjects, and in ice-cream shops for covering ice cream and desserts on a stick. The small capacity allows to process tiny chocolate quantities without any waste. The **practical removable tank** ensures an easy and fast maintenance. The **refined design** and **compact size** make it perfect to be used even directly on the counter.

Nero - Black  
MC09N

Rosso - Red  
MC09R

Grigio - Gray  
MC09G

Lilla - Lilac  
MC09L

Verde - Green  
MC09V



Termostato a regolazione manuale  
Manual regulation thermostat

Scocca in resistente materiale plastico  
Shell made of durable plastic material

1,8 L

Misure - Size:  
26x26 h16 cm



Vaschetta - Basin  
MC000305

Vasca estraibile in alluminio anodizzato  
Removable basin in anodized aluminum  
Ø 18,5 h10,7 cm

Chocolate

Su richiesta disponibili scioglitori con cablaggio GB / USA / GIAPPONE / AUSTRALIA / CINA.  
UK / US / JAPAN / AUSTRALIA / CHINA wirings available upon request.

# DeepMeltinChoc

MADE IN ITALY

Scioglitore a secco pensato per le gelaterie: grazie alla sua forma e dimensione è ideale per coperture in cioccolato di gelati e semifreddi su stecco. Presentato con colorazione classica, che ricorda i toni del cioccolato, per adattarsi ad ogni tipologia di arredo e per essere utilizzato direttamente sul banco. Le caratteristiche tecniche dello scioglitore analogico, tra cui il termostato che consente di regolare la temperatura e la vasca estraibile in alluminio anodizzato per una più facile pulizia, fanno di DEEP-MELTINCHOC un articolo essenziale.

Dry melter designed for ice-cream shops: thanks to its shape and size it is ideal for chocolate coatings of ice-creams and semifreddos on sticks. Presented with classic colours, reminiscent of chocolate tones, to adapt to all types of furnishings and to be used directly on the counter.

The technical features of the analogue melter, including the thermostat that allows you to adjust the temperature and the removable tank in anodised aluminium for easier cleaning, make DEEP-MELTINCHOC an essential item.



1,7 L

**Deep MeltinChoc  
MC10**

Ø 20,5 h21,2 cm



**Vaschetta - Basin  
MC001001**

Vasca estraibile in alluminio anodizzato  
Removable basin in anodized aluminum  
Ø 14 h18 cm

Scocca, coperchio e fondo in resistente materiale plastico  
Body, lid and bottom in durable plastic material

Su richiesta disponibili scioglitori con cablaggio GB / USA / GIAPPONE / AUSTRALIA / CINA.  
UK / US / JAPAN / AUSTRALIA / CHINA wirings available upon request.

# Chocobig

## EVOLUTION

Versatile, di facile utilizzo e di sicuro effetto. Ideale per pasticcerie, gelateria, ristoranti, alberghi e servizi catering.

La fontana Martellato, realizzata in Italia, è completamente in acciaio inox, ha la vasca smontabile per rendere svuotamento e pulizia molto facili. La manopola consente di regolare la temperatura e lo spegnimento automatico ne evita il surriscaldamento. Per il funzionamento richiede circa 3,5 kg di cioccolato e può contenerne fino a 8 kg.

Versatile, easy to use and highly impactful. Ideal for pastry shops, ice cream parlours, restaurants, hotels and catering services.

The Martellato fountain, made in Italy, is completely in stainless steel and has a removable basin to make emptying and cleaning very easy. The control knob allows you to adjust the temperature and the automatic switch-off prevents overheating. It requires about 3.5 kg of chocolate to operate and can hold up to 8 kg.



- ✓ MADE IN ITALY
- ✓ FUNZIONAMENTO SILENZIOSO  
SILENT OPERATION
- ✓ COCLEA IN ACCIAIO INOX  
STAINLESS STEEL AUGER
- ✓ VASCA SMONTABILE  
DISASSEMBLING BOWL

**CHOCOBIGEV**  
Ø 380 h800 mm  
Cap: ~ 3,5 lt  
230V - 50 Hz  
Amps 1.6A - 370W

## ACCESSORI - ACCESSORIES

Copri fontana in plexiglass con comodi ripiani.  
Plexiglass ring cover for chocolate fountain with useful displayers.

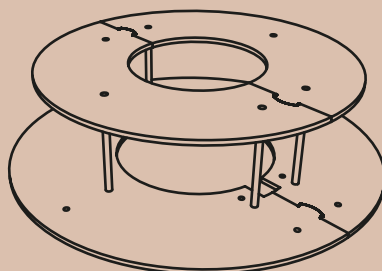

**CHOCOBIGRING06**  
Satinato - Satin-finish  
Ø 650 mm x h 170mm

# Chocolate Fountain



## CHOCOFONT

Ø 210mm h390mm  
Cap.: ~ 1 lt  
220 - 240V - 50 Hz  
Amps 0,77A - 170W

Compatta e leggera, la più piccola delle nostre fontane è adatta a sciogliere e mantenere il cioccolato alla temperatura desiderata nelle occasioni più informali o con spazi contenuti.

Compact and light, the smallest of our fountains is suitable for melting and maintaining chocolate at the desired temperature on the most informal occasions or with limited space.

- ✓ FONTANA IN ACCIAIO INOX  
STAINLESS STEEL FOUNTAIN
- ✓ COCLEA IN PLASTICA RESISTENTE  
AUGER IN HEAT RESISTANT PLASTIC
- ✓ PIEDINI REGOLABILI  
ADJUSTABLE FEET

Mantiene la cioccolata alla temperatura di 36/39°C.  
It keeps the chocolate at a temperature of 36/39°C.

## ACCESSORI - ACCESSORIES

Copri fontana in plexiglass con comodi ripiani.  
Plexiglass ring cover for chocolate fountain with useful displays.

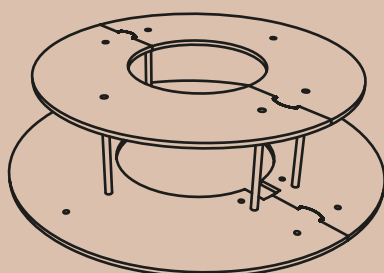

## CHOCORING06

Satinato - Satin-finish  
Ø 520mm x h 160mm



# SEMIFREDDO & BAKING

TRAVEL CAKE  
—○—  
**Geometric**  
by  
FRANK HAASNOOT

Dalla collaborazione tra Martellato e **Frank Haasnoot** nascono **nuove forme** per interpretare l'iconico Travel cake. **Stampi in acciaio inox**, realizzati in Italia, con inserto tubolare facilmente estraibile dopo la cottura, per consentire la farcitura del dolce anche con ripieni non da forno.

Made in Italy.





**New shapes** come from the collaboration between Martellato and **Frank Haasnoot**, to interpret the iconic Travel cake. Made in Italy **stainless steel moulds** with an easily removable after baking tubular insert, to fill the cakes with non-baked fillings.



Made in Italy.



## CARRÉ

### 30TC51F

Mould 82 x 290 h 64 mm  
 Cake 60 x 250 h 60 mm  
 Vol. ~ 900 ml  
 Prod. su teglia/on tray 60x40: 8 pcs

### 30TC50F

Mould 103 x 190 h 70 mm  
 Cake 80 x 150 h 69 mm  
 Vol. ~ 850 ml  
 Prod. su teglia/on tray 60x40: 10 pcs



## TRIANGLE

### 30TC52F

Mould 88 x 290 x h 85 mm  
 Cake 82 x 250 h 80 mm  
 Vol. ~ 890 ml  
 Prod. su teglia/on tray 60x40: 6 pcs



## FANCY

### 30TC53F

Mould 83,5 x 290 h 86 mm  
 Cake 60 x 250 h 80 mm  
 Vol. ~ 960 ml  
 Prod. su teglia/on tray 60x40: 8 pcs



## ROUND

### 30TC54F

Mould Ø 82 x 290 mm  
Cake Ø 78 x 250 mm  
Vol. ~ 1050 ml  
Prod. su teglia/on tray 60x40: 8 pcs



## CUBÓ

### 30TC55

Mould 130 x 86 h 83 mm  
Cake 80 x 80 h 80 mm  
Vol. ~ 510 ml  
Prod. su teglia/on tray 60x40: 20 pcs

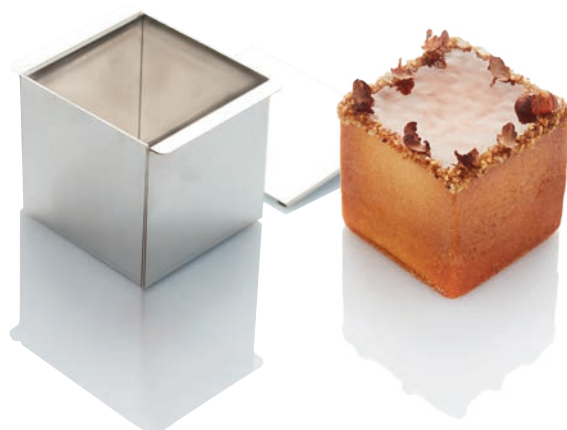

## BLOCK & OVAL

### 30TC56

Mould 255 x 84 h 62 mm  
Cake 250 x 60 h 60 mm  
Block Vol. ~ 900 ml - Oval Vol. ~ 790 ml  
Prod. su teglia/on tray 60x40: 8 pcs



# i MICRO BANDS FORATI

## The perfect baking solution

Fasce in silicone microforato, che abbinato agli stampi in acciaio inox, garantiscono cottura omogenea e senza umidità, sformatura facile senza rotture e una texture regolare ed elegante.

*Micro-perforated silicone bands, which combined with the stainless steel moulds, guarantee even cooking without humidity, easy demoulding without breakings and a regular and elegant texture.*



Watch the video in  
Martellato's YouTube channel.

"I MicroforatiBands sono la soluzione ideale per la razionalizzazione della produzione, la riduzione degli sprechi e un risultato estetico ineguagliabile."

*"The MicroforatiBands are the ideal solution for production optimization, waste reduction and unique aesthetics results"*

Denis Dianin AMPI Pastry Chef



## EFFICIENZA PRODUTTIVA

- **RAZIONALIZZAZIONE DELLA PRODUZIONE**  
semplificando i passaggi e riducendo i tempi di circa il 30%
- **COTTURA OMOGENEA E SENZA IMPERFEZIONI**  
in quanto permette la fuoriuscita dell'umidità
- **SFORMATURA VELOCE E SENZA ROTTURE**  
favorendo la rimozione del prodotto sia a caldo che a freddo
- **RIDUZIONE DEGLI SPRECHI E DEI COSTI**  
meno spreco di prodotto perché si avrà il 99 % di successo nella produzione



## PRODUCTION OPTIMIZATION

- **PRODUCTION RATIONALIZATION**  
by simplifying the steps and reducing times by around 30%
- **EVEN COOKING WITH ZERO IMPERFECTIONS**  
because they allow moisture to escape
- **QUICK DEMOULDING WITHOUT BREAKINGS**  
by allowing the unmoulding of both hot and cold products
- **WASTE AND COST REDUCTION**  
less product waste because you will have a 99% success rate with your production





## RISULTATI PERFETTI







- **ADATTABILITÀ A TUTTE LE FORME E A TUTTE LE RICETTE**
- **TEXTURE ELEGANTE** ed esclusiva
- **BORDI SOTTILI e DRITTI**  
che non collassano perché sostenuti dalla fascia
- **MINIMO SPAZIO DI STOCCAGGIO e FACILE GESTIONE**  
lavaggio ed asciugatura rapidi

## PERFECT RESULTS

- **ADAPTABILITY TO ALL SHAPES AND RECIPES**
- **ELEGANT AND EXCLUSIVE** texture
- **THIN AND STRAIGHT EDGES**  
that don't collapse because supported by the band
- **MINIMUM STORAGE AREA AND EASY MANAGEMENT**  
quick washing and drying



# MODELLI MODELS

<b>30BANDS01</b>	500xh25 mm 10 pcs	for	Ø 14 - 16	h 2,5 cm	
<b>30BANDS02</b>	625xh25 mm 10 pcs	for	Ø 18 - 20	h 2,5 cm	
<b>30BANDS03</b>	750xh25 mm 10 pcs	for	Ø 22 - 24	h 2,5 cm	
<b>30BANDS04</b>	500xh35 mm 10 pcs	for	Ø 14 - 16	h 3,5 cm	
<b>30BANDS05</b>	625xh35 mm 10 pcs	for	Ø 18 - 20	h 3,5 cm	
<b>30BANDS06</b>	750xh35 mm 10 pcs	for	Ø 22 - 24	h 3,5 cm	
<b>30BANDS07</b>	260xh20 mm 20 pcs	for	Ø 8	h 2 cm	



 +230°C  
+446°F



## PRODOTTI CORRELATI

### RELATED PRODUCTS

#### Fasce inox Stainless steel bands



<b>1H2X8</b>	Ø8 h2 cm
<b>1H25X14</b>	Ø14 h2,5 cm
<b>1H25X16</b>	Ø16 h2,5 cm
<b>1H25X18</b>	Ø18 h2,5 cm
<b>1H25X20</b>	Ø20 h2,5 cm
<b>1H25X22</b>	Ø22 h2,5 cm
<b>1H25X24</b>	Ø24 h2,5 cm
<b>1H35X14</b>	Ø14 h3,5 cm
<b>1H35X16</b>	Ø16 h3,5 cm
<b>1H35X18</b>	Ø18 h3,5 cm
<b>1H35X20</b>	Ø20 h3,5 cm
<b>1H35X22</b>	Ø22 h3,5 cm
<b>1H35X24</b>	Ø24 h3,5 cm



<b>5H25X14</b>	14X14 h2,5 cm
<b>5H25X16</b>	16X16 h2,5 cm
<b>5H25X18</b>	18X18 h2,5 cm
<b>5H35X14</b>	14X14 h3,5 cm
<b>5H35X16</b>	16X16 h3,5 cm
<b>5H35X18</b>	18X18 h3,5 cm

#### Tappeto in silicone microforato Micro-perforated silicone mat

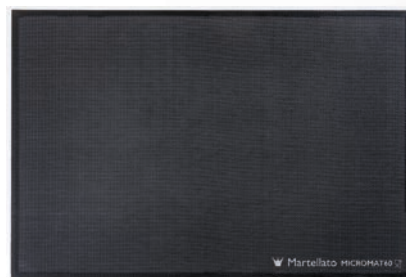

 +230°C  
+446°F

<b>MICROMAT60</b>	38,5 x 58,5 cm
<b>MICROMAT30</b>	38,5 x 28,5 cm

#### Dime - Template

Dime in plastica trasparente per il taglio in strisce regolari di pastafrolla, cioccolato e biscuit.  
Transparent plastic grids for cutting regular strips of pastry, chocolate and biscuit.

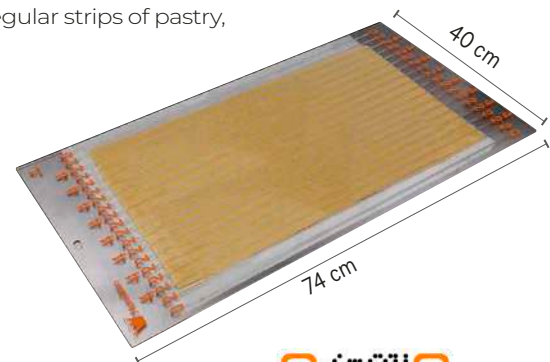

<b>50GD0022</b>	prod. 15 str.	60 x h2,2 cm
<b>50GD0027</b>	prod. 12 str.	60 x h2,7 cm
<b>50GD0037</b>	prod. 9 str.	60 x h3,7 cm

Guarda il video  
Watch the video



# i MICRO FORATI

stampi silicone  
silicone moulds

30x40

1 box: 2 stampi/moulds

Una linea di prodotti per cotture in forno, realizzati in silicone e fibra di vetro, pensati per facilitare il lavoro in laboratorio.

Le caratteristiche che li contraddistinguono, come l'alta qualità dei materiali e la texture microforata, consentono la diffusione uniforme del calore e l'uscita dell'umidità, riducendo i tempi di cottura e garantendo un risultato perfetto.

Tante forme ideali per le diverse preparazioni sia dolci che salate, come tartellette classiche e moderne, brioche e muffin.

Le creazioni risulteranno perfettamente croccanti e dalla forma impeccabile, senza bolle o cedimenti. Sono ideali anche per i lievitati, pasta frolla e brisée. I tappeti sono antiaderenti e possono essere usati da entrambi i lati, per preparare tartellette vuote o già farcite.

A line of products for oven baking, made of silicone and fibreglass, designed to simplify work in the laboratory.

The characteristics that distinguish them, such as the high quality of the materials and the micro-perforated texture, allow the uniform diffusion of heat and the exit of humidity, reducing cooking times and guaranteeing a perfect result.

The many different shapes are ideal for various preparations, both sweet and savoury, such as classic and modern tartlets, brioche and muffins. The creations will be perfectly crunchy and impeccably shaped, without bubbles or sagging. They are also ideal for leavened products, shortcrust pastry and brisée.

The mats are non-stick and can be used on both sides to prepare empty or already filled tartlets.

1 confezione = 2 stampi 30x40 per teglie 60x40

1 pack = 2 moulds 30x40 for 60x40 trays

# PLUS

Scopri i valori aggiunti che rivoluzionano la cottura in forno.  
Discover the added values that revolutionise oven cooking.

## RESISTENTI

Il silicone arricchito con fibra di vetro garantisce alta qualità e maggiore durata degli stampi.

Resiste a temperature fino a:  
+230°C +450°F

## RESISTANT

The silicone enriched with glass fibre guarantees high quality and longer life of the moulds.

Resistent up to:  
+ 230 ° C + 450 ° F

## PRATICI

Le sfornature sono più facili grazie all'antiaderenza del materiale

## PRACTICAL

Demoulding is easier thanks to the material non-stick qualities

## FUNZIONALI

La microforatura assicura una cottura veloce e uniforme, priva dell'umidità in eccesso

## FUNCTIONAL

Microperforation ensures even and quick cooking with no humidity excess

## VERSATILI

Possono essere usati da entrambi i lati per risultati creativi

## VERSATILE

Can be used on both sides for creative results

## MULTIUSO

Consentono di realizzare qualsiasi tipo di ricetta, dolce o salata

## MULTI-USE

Allow making any type of sweet or savoury recipe

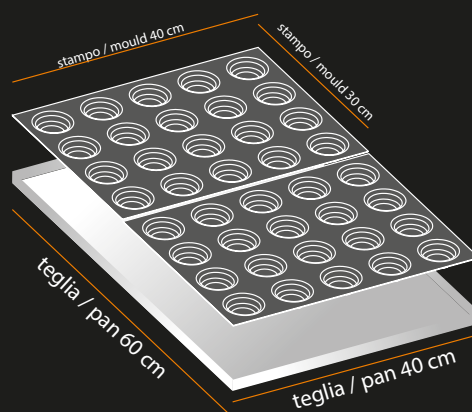

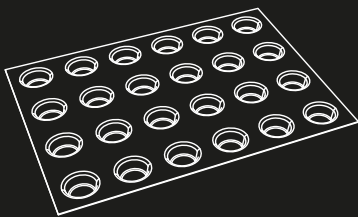

h16

Ø40mm

**30MICRO01**

Prod: 24+24 pcs

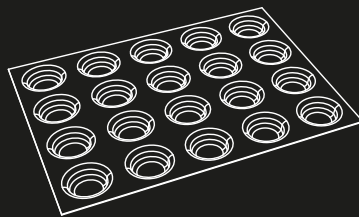

h16

Ø50mm

**30MICRO02**

Prod: 20+20 pcs

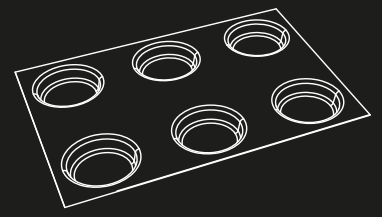

h20

Ø85mm

**30MICRO04**

Prod: 6+6 pcs

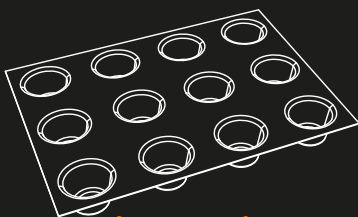

h40mm

Ø60mm

**30MICRO03**

Prod: 12+12 pcs

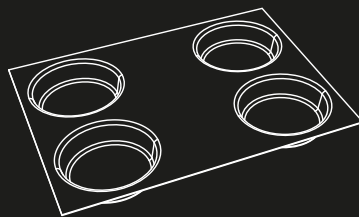

h30mm

Ø120mm

**30MICRO05**

Prod: 4+4 pcs

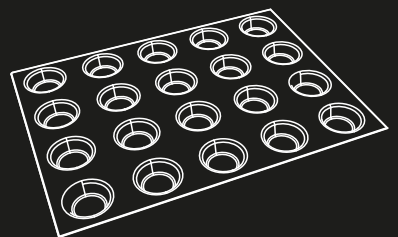

h22

Ø48mm

**30MICRO10**

Prod: 20+20 pcs

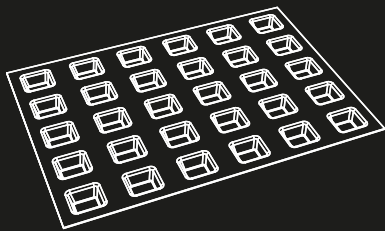

h16  
35x35mm  
**30MICRO06**  
Prod: 30+30 pcs

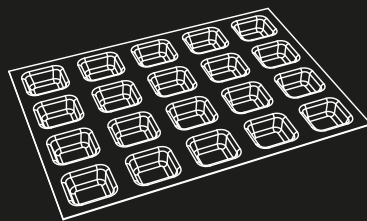

h20  
50x50mm  
**30MICRO07**  
Prod: 20+20 pcs

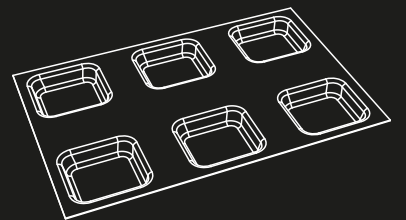

h20  
85x85mm  
**30MICRO08**  
Prod: 6+6 pcs

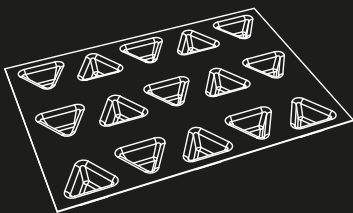

h25mm  
60mm  
**30MICRO09**  
Prod: 15+15 pcs

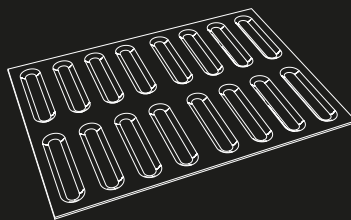

h6mm  
120mm  
**30MICRO11**  
Prod: 16+16 pcs  
120x25 - h6mm

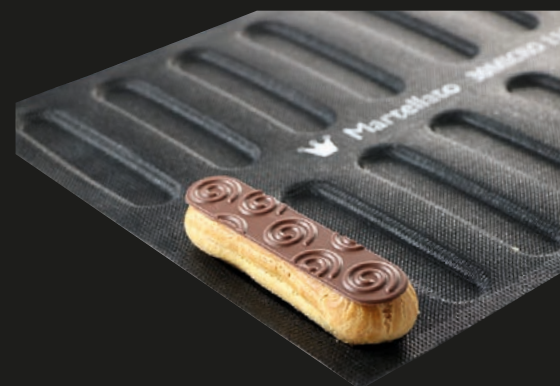

# One STRIP



## IL FUTURO È IN UN GESTO

Una nuova generazione di stampi Made in Italy che stanno cambiando il modo di lavorare in laboratorio.

Pratici, economici e veloci, gli stampi monouso per torte e individual cake consentono di velocizzare la produzione di semifreddi, risparmiando tempo, riducendo i costi, eliminando l'uso di detergenti e il consumo di acqua dovuto ai lavaggi.

## THE FUTURE IS IN ONE MOVE

A new generation of Made in Italy moulds that are changing the way professionals work in the laboratory.

Practical, economical and fast, disposable moulds for cakes and individual cakes allow you to speed up production of semifreddo, saving time, reducing costs and eliminating the use of detergents and water consumption due to washing.

100%   
**RECYCLABLE**





## PERCHÉ SCEGLIERE ONE STRIP?

### Con One Strip avrai:

- **30%** dei TEMPI di produzione
- **15%** del COSTO dei materiali
- **20%** della MANODOPERA
- **25%** dei CONSUMI

## WHY CHOOSE ONE STRIP?

### One Strip saves:

- **30%** of production TIMES
- **15%** of the COSTS of materials
- **20%** of LABOUR
- **25%** of CONSUMPTION

## CAKE MOULD

### ONE14H35

Ø 140 x h 35 mm  
Pack 140 pcs

### ONE14H40

Ø 140 x h 40 mm  
Pack 140 pcs

### ONE16

Ø 160 x h 40 mm  
Pack 100 pcs

### ONE18

Ø 180 x h 40 mm  
Pack 100 pcs

### ONE20

Ø 200 x h 40 mm  
Pack 100 pcs

### ONE22

Ø 220 x h 40 mm  
Pack 100 pcs



## INDIVIDUAL

### ONE06

Ø 63 x h 40 mm  
Prod. 6 pcs/bar  
Pack 72 bars  
Prod. for 60x40 tray  
6x9=54 pcs





# BLACK sil

Silicone Moulds

Una linea di stampi in silicone alimentare di alta qualità e design per esaltare l'estetica ed il gusto delle vostre produzioni. Forme moderne ed essenziali, facili da sformare, che assicurano sempre ottimi risultati. Adatti per preparazioni sia dolci che salate, gli stampi made in Italy Martellato mantengono inalterate nel tempo le loro caratteristiche.

High quality and top design food grade silicone moulds to enhance the aesthetics and taste of your products. Modern and essential shapes, easy to unmould, that always ensure excellent results. Suitable for both sweet and savoury preparations, Martellato's made in Italy moulds maintain their characteristics and quality unchanged over time.



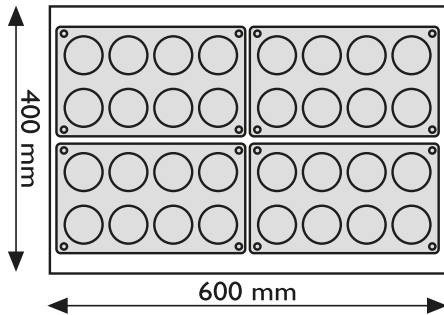

Stampi in silicone con scatola  
Silicone moulds with box  
Stampo/mould: **297 x 176 mm**

**Una teglia 60x40** può contenere  
**4 stampi** 297 x 176 mm.  
**A 60x40 tray** can contain  
**4 moulds** 297 x 176 mm.

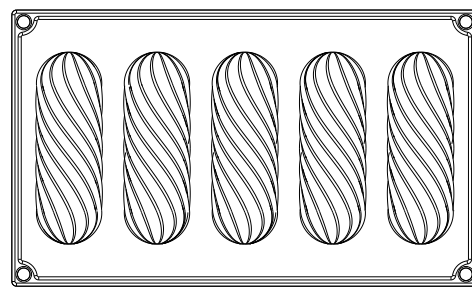

## TWIST ECLAIR

**30SIL505**

Single portion: 120 x 40 h 33 mm  
Vol. ~ 110 ml - Prod. 5 pcs

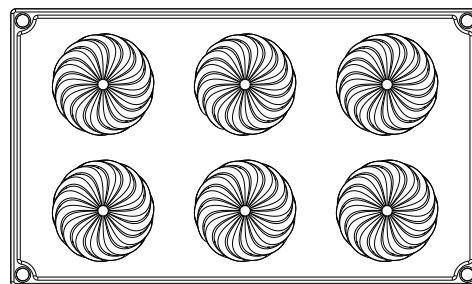
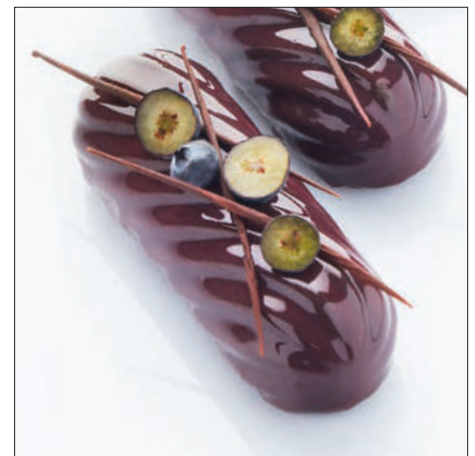

## TWIST

**30SIL506**

Single portion: Ø 62 h 55 mm  
Vol. ~ 110 ml - Prod. 6 pcs



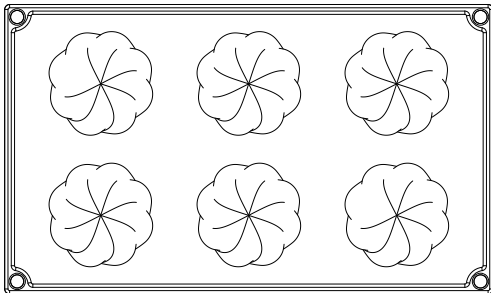

## HARMONY

**30SIL508**

Single portion: 63 x 63 h 53 mm  
Vol. ~ 110 ml - Prod. 6 pcs

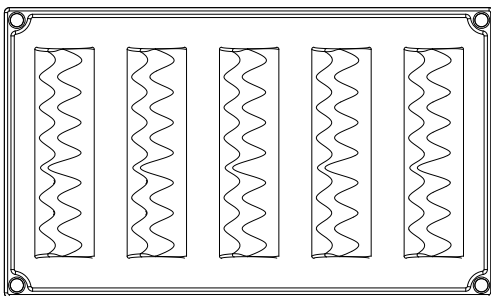

## RITMO

**30SIL509**

Single portion: 128 x 36 h 32,5 mm  
Vol. ~ 108 ml - Prod. 5 pcs





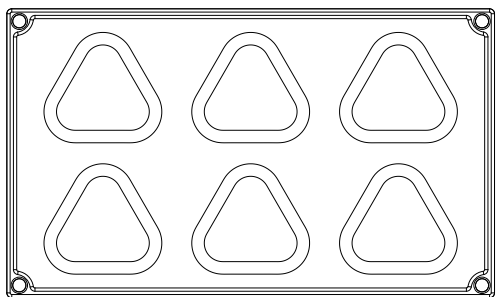

## TRIANGLE

**30SIL507**

Single portion: 71,5 x 67 h 35,5 mm  
Vol. ~ 104 ml - Prod. 6 pcs

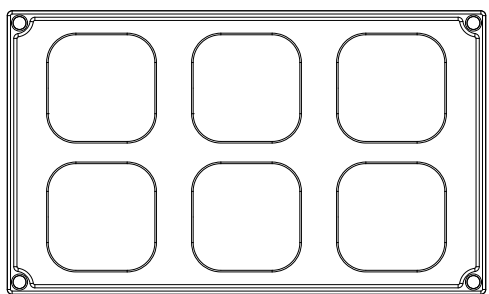

## BOX

**30SIL501**

Single portion: 64 x 64 h 34 mm  
Vol. ~ 115 ml - Prod. 6 pcs

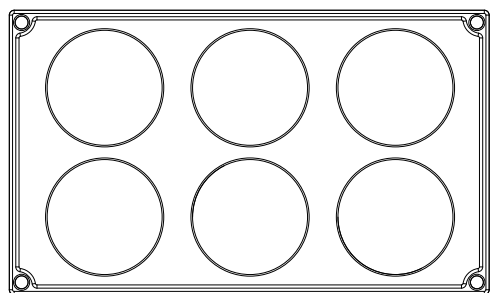

## CIRCLE

**30SIL500**

Single portion: Ø 69 h 35 mm  
Vol. ~ 110 ml - Prod. 6 pcs



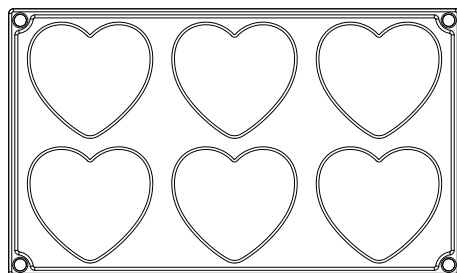

## LOVE

**30SIL502**

Single portion: 74,5 x 68 h 30 mm  
Vol. ~ 89 ml - Prod. 6 pcs

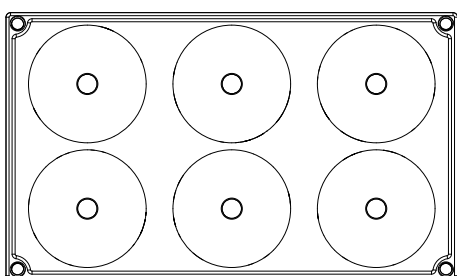

## DONUTS

**30SIL503**

Single portion: Ø 75 h 25 mm  
Vol. ~ 89 ml - Prod. 6 pcs

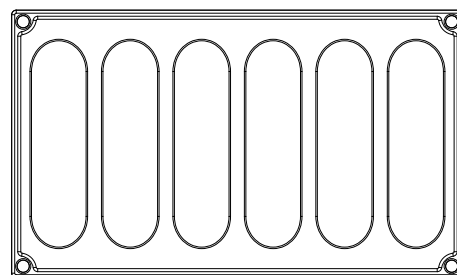

## ECLAIR

**30SIL504**

Single portion: 130 x 30 h 28 mm  
Vol. ~ 84 ml - Prod. 6 pcs



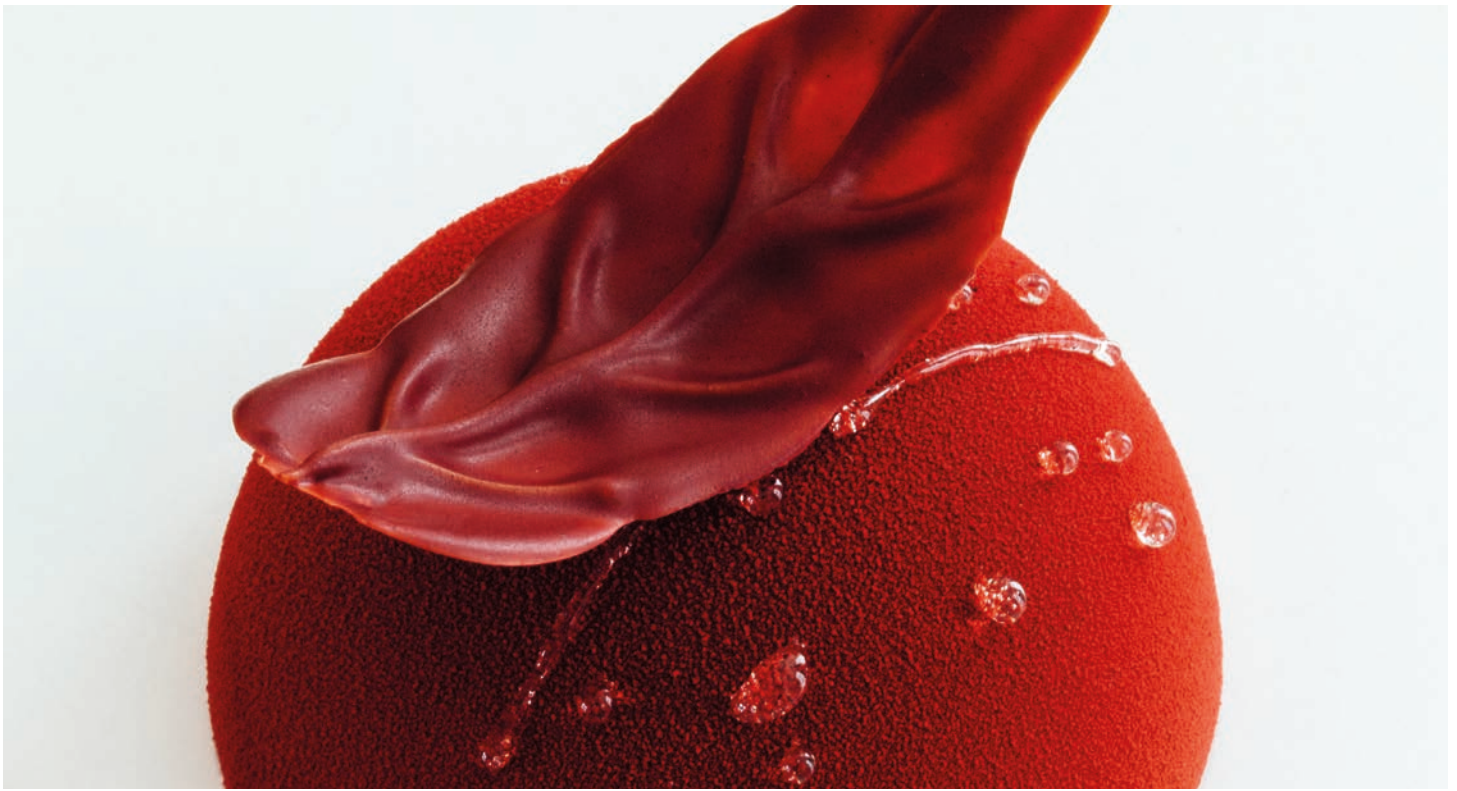

## HALF-SPHERES



**30SF001**

Ø 80 h 40 mm  
Prod. 5 pcs



**30SF002**

Ø 70 h 35 mm  
Prod. 6 pcs



**30SF003**

Ø 60 h 30 mm  
Prod. 6 pcs



**30SF004**

Ø 50 h 25 mm  
Prod. 8 pcs



**30SF005**

Ø 40 h 20 mm  
Prod. 15 pcs



**30SF006**

Ø 30 h 15 mm  
Prod. 24 pcs



**30SF500**

Ø 45 h 22,5 mm  
Prod. 15 pcs



**30SF501**

Ø 35 h 17,5 mm  
Prod. 18 pcs



**30SF502**

Ø 25 h 12,5 mm  
Prod. 28 pcs



# OTHERS SHAPES



**30SF032**

68x45 h 17 mm  
Prod. 9 pcs



**30SF031**

44x34 h 10 mm  
Prod. 15 pcs

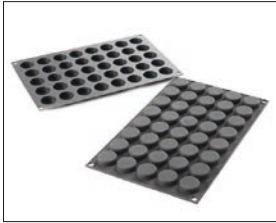

**30SF180**

Ø27 h11 mm  
Prod. 40 pcs

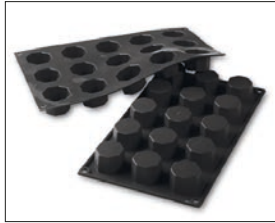

**30SF037**

Ø38 h 26 mm  
Prod. 15 pcs



**30SF044**

Ø50 h 14 mm  
Prod. 15 pcs



**30SF045**

Ø60 h 17 mm  
Prod. 8 pcs



**30SF046**

Ø70 h 17 mm  
Prod. 6 pcs



**30SF047**

Ø80 h 18 mm  
Prod. 6 pcs



**30SF042**

Ø100 h 20 mm  
Prod. 3 pcs



**30SF102**

Ø68 h 38 mm  
Prod. 6 pcs



**30SF023**

Ø 69 h 35 mm  
Prod. 6 pcs



**30SF052**

Ø75 h 60 mm  
Prod. 6 pcs



**30SF024**

Ø 81 h 32 mm  
Prod. 5 pcs



**30SF022**

Ø 51 h 28 mm  
Prod. 11 pcs





**30SF007**

71x71 h 40 mm  
Prod. 6 pcs



**30SF008**

36x36 h 22 mm  
Prod. 15 pcs



**30SF009**

Ø 34 h 16 mm  
Prod. 24 pcs



**30SF013**

Ø 45 h 10 mm  
Prod. 15 pcs

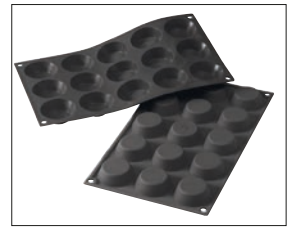

**30SF014**

Ø 50 h 15 mm  
Prod. 15 pcs



**30SF015**

Ø 60 h 17 mm  
Prod. 8 pcs



**30SF016**

Ø 70 h 20 mm  
Prod. 6 pcs



**30SF017**

55x33 h 20 mm  
Prod. 16 pcs



**30SF057**

Ø55 h 36 mm  
Prod. 8 pcs



**30SF019**

Ø 35 h 38 mm  
Prod. 15 pcs



**30SF020**

Ø 45 h 48 mm  
Prod. 11 pcs



**30SF021**

Ø 55 h 60 mm  
Prod. 8 pcs



**30SF022**

Ø 51 h 28 mm  
Prod. 11 pcs



**30SF023**

Ø 69 h 35 mm  
Prod. 6 pcs



**30SF024**

Ø 81 h 32 mm  
Prod. 5 pcs



**30SF030**

Ø35 h 5 mm  
Prod. 24 pcs



**30SF027**

Ø40 h 20 mm  
Prod. 15 pcs



**30SF028**

Ø60 h 35 mm  
Prod. 8 pcs



**30SF029**

Ø60 h 12 mm  
Prod. 8 pcs



**30SF155**

130x81 h 17mm  
Prod. 4 pcs



**30SF056**

Ø70 h 28 mm  
Prod. 6 pcs



**30SF033**

Ø35 h 35 mm  
Prod. 18 pcs



**30SF034**

Ø76 h 37 mm  
Prod. 6 pcs



**30SF035**

Ø79 h 30 mm  
Prod. 6 pcs



**30SF168**

69x69 h 60mm  
Prod. 6 pcs



**30SF058**

Ø70 h 36 mm  
Prod. 6 pcs



**30SF059**

Ø45 h 45 mm  
Prod. 18 pcs



**30SF060**

50x25 h 20 mm  
Prod. 20 pcs



**30SF061**

Ø75 h 40 mm  
Prod. 2x3 pcs



**30SF103**

127,5x47 h 17 mm  
Prod. 6 pcs



**30SF036**

Ø65 h 60 mm  
Prod. 6 pcs



**30SF040**

Ø60 h 35 mm  
Prod. 8 pcs



**30SF054**

95x45 h 12 mm  
Prod. 7 pcs



**30SF114**

95x35 h 25 mm  
Prod. 7 pcs



**30SF161**

125x28 h 5mm  
Prod. 4 pcs



**30SF048**

Ø35 h 23 mm  
Prod. 18 pcs

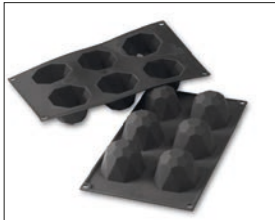

**30SF049**

Ø68 h 45 mm  
Prod. 6 pcs



**30SF050**

Ø55 h 50 mm  
Prod. 8 pcs



**30SF051**

Ø57 h 57 mm  
Prod. 8 pcs



**30SF025**

49x26 h 11 mm  
Prod. 20 pcs



**30SF026**

79x29 h 30 mm  
Prod. 12 pcs





Stampi per alta produttività.  
High productivity moulds.

Silicone moulds 595x395 mm



## MUFFIN

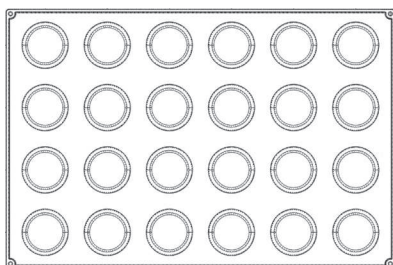

**30SILO7N**

Ø69 h 39 mm - Vol. ~ 120 ml  
Prod. 24 pcs

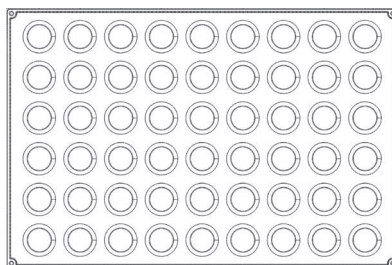

**30SILO6N**

Ø50 h 28 mm - Vol. ~ 40 ml  
Prod. 54 pcs





## HALF-SPHERE

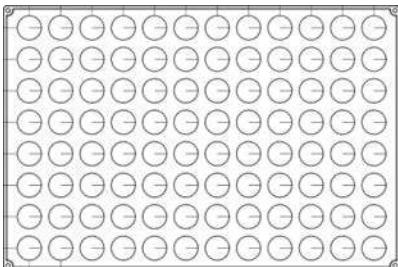

### 30SILO5N

Single portion: Ø 35 h 17,5 mm  
Vol. ~ 10 ml - Prod. 96 pcs

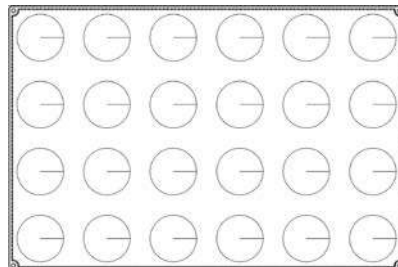

### 30SILO4N

Single portion: Ø 70 h 35 mm  
Vol. ~ 90 ml - Prod. 24 pcs



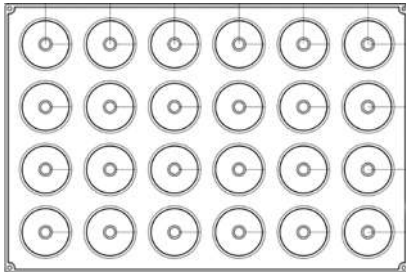

## DONUTS

**30SIL01N**

Single portion: Ø 75 h 25 mm  
Vol. ~ 89 ml - Prod. 24 pcs

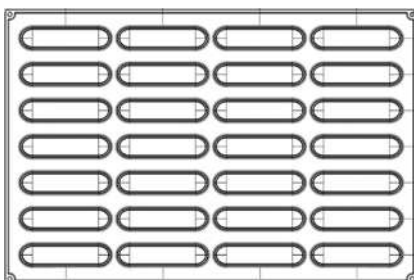

## ECLAIR

**30SIL02N**

Single portion: 130 x 30 h 28 mm  
Vol. ~ 84 ml - Prod. 28 pcs



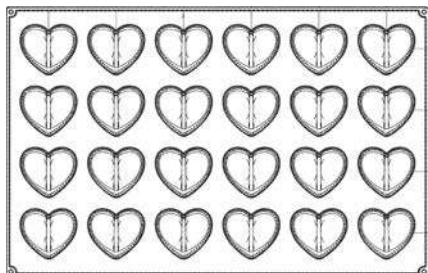

## LOVE

**3OSILO3N**

Single portion: 74,5 x 68 h 30 mm  
Vol. ~ 89 ml - Prod. 24 pcs

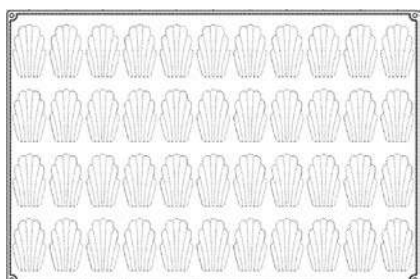

## MADELINE

**3OSILO8N**

Single portion: 74 x 45 h 18 mm  
Vol. ~ 35 ml - Prod. 44 pcs



# Baking Pan

## Silicone Moulds

Stampi in silicone alimentare antiaderente e sono adatti all'uso in abbattitore e in forno.

Moulds made of non-stick food grade silicone suitable for use in blast chillers and ovens.



+230° / -60°C  
+446° / -76°F



CUORE - HEART

**SFT 210/Y**

220x218 h 40 mm



MARGUERITE

**SFT 220/Y**

Ø220 h 45 mm



CIAMBELLA - SAVARIN

**SFT 224/Y**

Ø240 h 60 mm



GUGELHOPF

**SFT 250/Y**

Ø220 h 110 mm



ROSA - ROSE

**SFT 251/Y**

Ø220 h 100 mm



RECTANGULAR

**SFT 300/Y**

280x220 h 40 mm

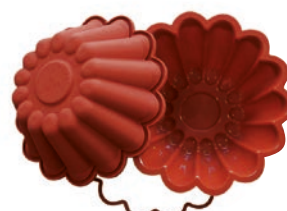

BRIOCHE

**SFT 522/Y**

Ø220 h 80 mm

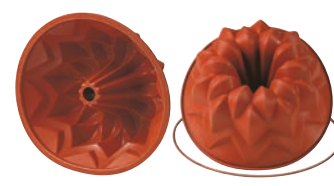

STAR BUNDT

**SFT 600/Y**

Ø240 h 100 mm



PLUM CAKE

**SFT 326/Y**

240x105 h 65 mm

**SFT 330/Y**

260x100 h 70 mm  
con anello/with ring



CROSTATATA - FLAN PAN

**SFT 424/Y**

Ø240 h 30 mm

**SFT 426/Y**

Ø260 h 30 mm

**SFT 428/Y**

Ø280 h 30 mm



TONDO - ROUND

**SFT 118/Y**

Ø180 h 40 mm

**SFT 124/Y**

Ø240 h 42 mm

**SFT 120/Y**

Ø200 h 40 mm

**SFT 128/Y**

Ø280 h 47 mm

**SFT 122/Y**

Ø220 h 42 mm

**SFT 126/Y**

Ø260 h 45 mm

Stampi per gelatine, in puro silicone alimentare, per la realizzazione di gelatine alla frutta, fondenti, ecc. Cornice in plastica. Stampo: 180x335 mm.

Jelly moulds, in pure food-grade silicone, for making fruit jellies, fondants, etc. Plastic frame. Mould: 180x335 mm



**FETTA ARANCIA**  
**ORANGE SLICE**

**SG 01**

Size:45x18 h 15 mm  
24 fig.



**CUORE**  
**HEART**

**SG 03**

Size:34x30 h 18 mm  
24 fig.



**ANANAS**  
**PINEAPPLE**

**SG 07**

Size:33x23 h 18 mm  
24 fig.



**FRAGOLA**  
**STRAWBERRY**

**SG 08**

Size:36x30 h 20 mm  
24 fig.



**PESCA**  
**PEACH**

**SG 09**

Size:35x25 h 20 mm  
24 fig.



**MORA**  
**BERRY**

**SG 06**

Size:Ø30 h 24 mm  
24 fig.



**SEMISFERE**  
**HALFSPHERE**

**SG 04**

Size:Ø27 h 13,5 mm  
24 fig.



**PERA**  
**PEAR**

**SG 02**

Size:40x26 h 15 mm  
24 fig.



**BON BON**  
**PASTILLE**

**SG 05**

Size:Ø30 h 11 mm  
24 fig.

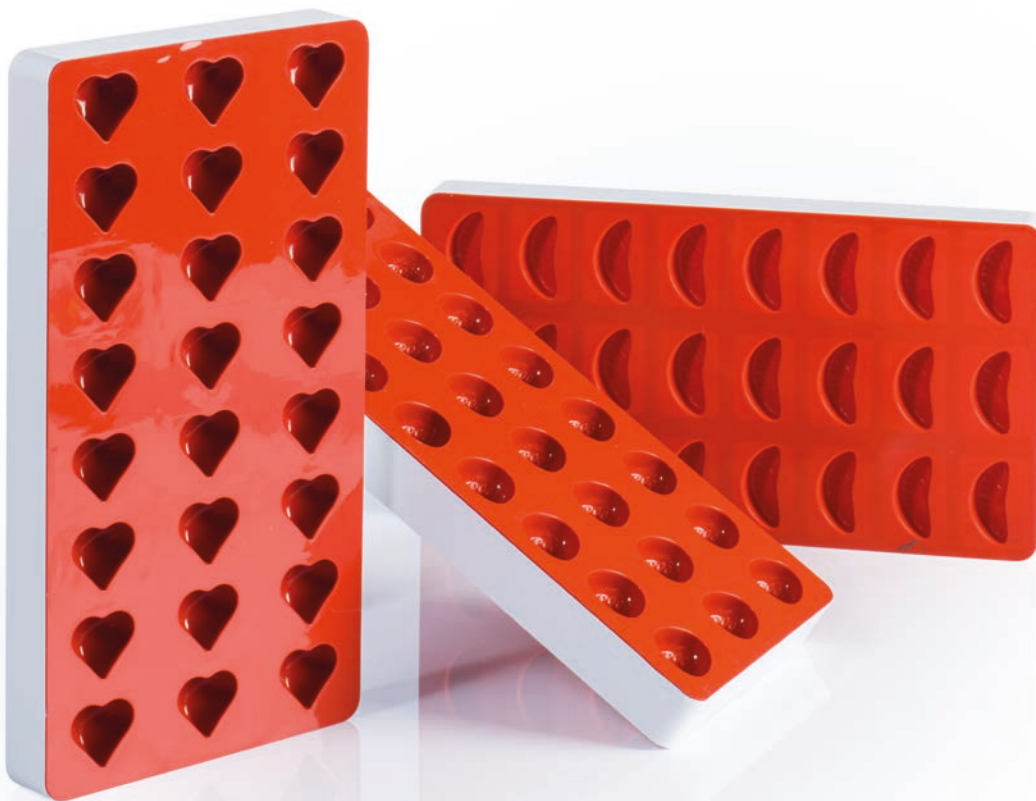

# Eclair

MANIA



## TAPPETI SILICONE SILICONE MATS

**Eclair 25x125mm**

**30TE6001R**

58,5x38,6 cm - 36 pcs

**30TE3001R**

29,8x39,8 cm - 18 pcs

**Mini Eclair 18x60mm**

**30TE6002R**

58,5x38,6 cm - 70 pcs

**30TE3002R**

29,8x39,8 cm - 35 pcs



STAMPI PER DECORAZIONI DI CIOCCOLATO  
MOULDS FOR CHOCOLATE DECORATIONS

**Eclair 25x125mm**

**20EC01**

Kit 6 stampi / moulds  
prod 36 pcs

**Mini Eclair 18x60mm**

**20EC02**

Kit 6 stampi / moulds  
prod 72 pcs



TAGLIAPASTA PER DECORAZIONI  
PASTRY CUTTER FOR DECORATIONS

**Eclair 25x125mm**

**31CUT01**

**Mini Eclair 18x60mm**

**31CUT02**

# Macaron MANIA



## TAPPETI SILICONE SILICONE MATS

Macaron Ø40mm

**30TM6001R**

58,5x38,6 cm

70 gusci/shells

Macaron Ø40mm

**30TM3001R**

30x40cm

34 gusci/shells

## DIME / TEMPLATE

Il prodotto va posizionato su foglio di carta da forno, la cui trasparenza permette di vedere dove posizionare l'impasto di Eclaire / Macaron, e sfilato prima della cottura.

**Non adatto alla cottura**

The product must be placed on a sheet of baking paper, whose transparency allows to see where to place the mixture of Eclaire / Macaron, and removed before baking.

**Not suitable for cooking**

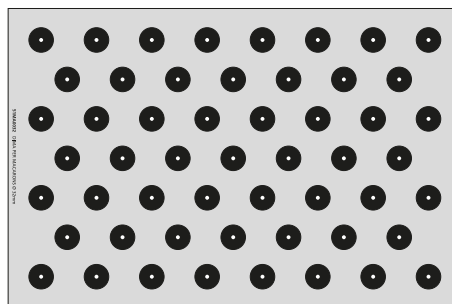

Macaron Ø32mm

**51MA0032**

Dima in plastica - Plastic template 59x39 cm  
Prod. 53 gusci/shells



Created by  **FRANK  
HAASNOT**

# pastry RING

Fasce in acciaio inox di alta qualità con **bordi perfettamente dritti**, spessi per maggiore indeformabilità e **superficie liscia** per facilità di sformatura e dessert impeccabili. Adatti all'utilizzo sia in forno, dove assicurano cottura uniforme che in congelatore ed in abbattitore, per un completo e veloce raffreddamento., La varietà di forme e dimensioni, unita alle ampie possibilità di personalizzazione del soggetto su richiesta, rendono le fasce Martellato delle **soluzioni versatili** in grado di soddisfare anche i pasticceri più esigenti.

High quality stainless steel cake band with **perfectly straight edges**, more thickness for greater non-deformability and **smooth surface** for ease demoulding and flawless desserts. Suitable for use in freezer and blast chiller for a complete and fast cooling and ensure even cooking. The variety of shapes and sizes, combined with the wide customization opportunities upon request, make Martellato rings **very versatile products** able to satisfy even the most demanding pastry chefs.





## STRIPE

H. 40 mm

**49H4X25** 62 x 252 600 ml

**49H4X27** 81 x 272 850 ml

**49H4X29** 92 x 292 1000 ml



## QUENELLE

H. 40 mm

**48H4X18** 92 x 182 440 ml

**48H4X23** 124 x 227 750 ml

**48H4X25** 142 x 249 1000 ml



## PILLOW

H. 40 mm

<b>46H4X18</b>	67 x 182	360	ml
<b>46H4X21</b>	94 x 209	600	ml
<b>46H4X27</b>	121 x 270	1000	ml



## TRIS

H. 40 mm

<b>47H4X15</b>	146 x 134	510	ml
<b>47H4X17</b>	170 x 159	750	ml
<b>47H4X20</b>	197 x 184	1000	ml



## DONUT

H. 40 mm

**43H4X18** Ø 180 - foro/hole Ø 100 713 ml

**43H4X20** Ø 200 - foro/hole Ø 120 813 ml



## CALISSON

H. 40 mm

**41H4X9** 90 x 50 127 ml

**41H4X15** 150 x 83 353 ml

**41H4X22** 220 x 122 759 ml



## DIAMOND CIRCLE

H. 40 mm

**44H4X14** Ø 144 604 ml

**44H4X17** Ø 171 850 ml

**44H4X20** Ø 202 1200 ml



## DIAMOND HEART

H. 40 mm

<b>45H4X15</b>	150 x 138	550	ml
<b>45H4X19</b>	186 x 171	850	ml
<b>45H4X20</b>	202 x 184	1000	ml

## HEART

### H. 50 mm

<b>42H5X10</b>	100 x 94	324	ml
<b>42H5X12</b>	120 x 113	466	ml
<b>42H5X14</b>	140 x 131	634	ml
<b>42H5X16</b>	160 x 150	828	ml
<b>42H5X18</b>	180 x 169	1048	ml
<b>42H5X20</b>	200 x 187	1294	ml
<b>42H5X22</b>	220 x 207	1550	ml
<b>42H5X24</b>	240 x 225	1845	ml
<b>42H5X26</b>	260 x 244	2170	ml
<b>42H5X28</b>	280 x 263	2540	ml

### H. 40 mm

<b>42H4X10</b>	100 x 94	259	ml
<b>42H4X12</b>	120 x 113	373	ml
<b>42H4X14</b>	140 x 131	507	ml
<b>42H4X16</b>	160 x 150	663	ml
<b>42H4X18</b>	180 x 169	839	ml
<b>42H4X20</b>	200 x 187	1035	ml
<b>42H4X22</b>	220 x 207	1240	ml
<b>42H4X24</b>	240 x 225	1480	ml
<b>42H4X26</b>	260 x 244	1730	ml
<b>42H4X28</b>	280 x 263	2030	ml



## INCLINED HEART

### H. 40 mm

<b>18H4X17</b>	175 x 180	1490	ml
<b>18H4X20</b>	200 x 206	1010	ml
<b>18H4X26</b>	260 x 267	1704	ml

### H. 50 mm

<b>18H5X17</b>	175 x 180	1863	ml
<b>18H5X20</b>	200 x 206	1262	ml
<b>18H5X26</b>	260 x 267	2130	ml

# ROUND



## H. 60 mm

<b>1H6X6</b>	Ø 60	565	ml
<b>1H6X8</b>	Ø 80	754	ml
<b>1H6X10</b>	Ø 100	942	ml
<b>1H6X12</b>	Ø 120	1130	ml
<b>1H6X14</b>	Ø 140	1319	ml
<b>1H6X16</b>	Ø 160	1507	ml
<b>1H6X18</b>	Ø 180	1696	ml
<b>1H6X20</b>	Ø 200	1884	ml
<b>1H6X22</b>	Ø 220	2072	ml
<b>1H6X24</b>	Ø 240	2261	ml
<b>1H6X26</b>	Ø 260	3184	ml
<b>1H6X28</b>	Ø 280	3693	ml

## H. 50 mm

<b>1H5X10</b>	Ø 100	393	ml
<b>1H5X12</b>	Ø 120	566	ml
<b>1H5X14</b>	Ø 140	770	ml
<b>1H5X16</b>	Ø 160	1005	ml
<b>1H5X18</b>	Ø 180	1272	ml
<b>1H5X20</b>	Ø 200	1571	ml
<b>1H5X22</b>	Ø 220	1901	ml
<b>1H5X24</b>	Ø 240	2262	ml
<b>1H5X26</b>	Ø 260	2655	ml
<b>1H5X28</b>	Ø 280	3079	ml
<b>1H5X30</b>	Ø 300	3534	ml

## ROUND



### H. 40 mm

<b>1H4X8</b>	Ø 80	202	ml
<b>1H4X10</b>	Ø 100	314	ml
<b>1H4X12</b>	Ø 120	452	ml
<b>1H4X14</b>	Ø 140	616	ml
<b>1H4X16</b>	Ø 160	804	ml
<b>1H4X18</b>	Ø 180	1018	ml
<b>1H4X20</b>	Ø 200	1257	ml
<b>1H4X22</b>	Ø 220	1521	ml
<b>1H4X24</b>	Ø 240	1810	ml
<b>1H4X26</b>	Ø 260	2124	ml
<b>1H4X28</b>	Ø 280	2463	ml
<b>1H4X30</b>	Ø 300	2827	ml

### H. 35 mm

<b>1H35X14</b>	Ø 140	539	ml
<b>1H35X16</b>	Ø 160	704	ml
<b>1H35X18</b>	Ø 180	891	ml
<b>1H35X20</b>	Ø 200	1100	ml
<b>1H35X22</b>	Ø 220	1330	ml
<b>1H35X24</b>	Ø 240	1583	ml

### H. 30 mm

<b>1H3X10</b>	Ø 100	150	ml
<b>1H3X18</b>	Ø 180	848	ml

### H. 25 mm

<b>1H25X14</b>	Ø 140	385	ml
<b>1H25X16</b>	Ø 160	503	ml
<b>1H25X18</b>	Ø 180	636	ml
<b>1H25X20</b>	Ø 200	785	ml
<b>1H25X22</b>	Ø 220	950	ml
<b>1H25X24</b>	Ø 240	1131	ml

### H. 20 mm

<b>1H2X8</b>	Ø 80	101	ml
<b>1H2X10</b>	Ø 100	157	ml
<b>1H2X12</b>	Ø 120	226	ml
<b>1H2X14</b>	Ø 140	308	ml
<b>1H2X16</b>	Ø 160	402	ml
<b>1H2X18</b>	Ø 180	509	ml
<b>1H2X20</b>	Ø 200	628	ml
<b>1H2X22</b>	Ø 220	760	ml
<b>1H2X24</b>	Ø 240	905	ml
<b>1H2X26</b>	Ø 260	1062	ml
<b>1H2X28</b>	Ø 280	1232	ml

# SQUARE



## H. 60 mm

<b>5H6X6</b>	60 x 60	216 ml
<b>5H6X8</b>	80 x 80	384 ml
<b>5H6X10</b>	100 x 100	600 ml
<b>5H6X12</b>	120 x 120	3744 ml

## H. 50 mm

<b>5H5X10</b>	102 x 102	520 ml
<b>5H5X12</b>	122 x 122	744 ml
<b>5H5X14</b>	142 x 142	1008 ml
<b>5H5X16</b>	162 x 162	1312 ml
<b>5H5X18</b>	182 x 182	1656 ml
<b>5H5X20</b>	202 x 202	2040 ml
<b>5H5X22</b>	222 x 222	2464 ml
<b>5H5X24</b>	242 x 242	2928 ml
<b>5H5X26</b>	262 x 262	812 ml
<b>5H5X28</b>	282 x 282	3976 ml
<b>5H5X30</b>	302 x 302	4560 ml

## H. 40 mm

<b>5H4X10</b>	102 x 102	416 ml
<b>5H4X12</b>	122 x 122	595 ml
<b>5H4X14</b>	142 x 142	807 ml
<b>5H4X16</b>	162 x 162	1050 ml
<b>5H4X18</b>	182 x 182	1325 ml
<b>5H4X20</b>	202 x 202	1632 ml
<b>5H4X22</b>	222 x 222	1971 ml
<b>5H4X24</b>	242 x 242	2343 ml
<b>5H4X26</b>	262 x 262	650 ml
<b>5H4X28</b>	282 x 282	3181 ml
<b>5H4X30</b>	302 x 302	3648 ml

## H. 35 mm

<b>5H35X14</b>	142 x 142	706 ml
<b>5H35X16</b>	162 x 162	913 ml
<b>5H35X18</b>	182 x 182	1159 ml

## H. 25 mm

<b>5H25X14</b>	142 x 142	504 ml
<b>5H25X16</b>	162 x 162	652 ml
<b>5H25X18</b>	182 x 182	828 ml

## OVAL

### H. 40 mm

<b>2H4X12</b>	135 x 100	429 ml
<b>2H4X14</b>	160 x 120	610 ml
<b>2H4X16</b>	185 x 135	796 ml
<b>2H4X18</b>	205 x 155	1009 ml
<b>2H4X20</b>	225 x 175	1248 ml
<b>2H4X22</b>	253 x 190	1528 ml
<b>2H4X26</b>	300 x 220	2102 ml
<b>2H4X28</b>	320 x 250	2535 ml
<b>2H4X30</b>	345 x 260	2850 ml



## DROP

### H. 40 mm

<b>8H4X10</b>	128 x 82	273 ml
<b>8H4X12</b>	156 x 100	391 ml
<b>8H4X14</b>	176 x 115	511 ml
<b>8H4X16</b>	206 x 127	650 ml
<b>8H4X18</b>	226 x 146	831 ml
<b>8H4X20</b>	251 x 165	1049 ml
<b>8H4X22</b>	271 x 180	1240 ml
<b>8H4X24</b>	300 x 196	1490 ml
<b>8H4X26</b>	325 x 210	1724 ml
<b>8H4X28</b>	330 x 255	1986 ml
<b>8H4X30</b>	355 x 270	2315 ml



## HEXAGONAL

### H. 50 mm

<b>3H5X7</b>	121 x 140	637 ml
<b>3H5X8</b>	139 x 160	831 ml
<b>3H5X10</b>	173 x 200	1299 ml
<b>3H5X12</b>	208 x 240	1871 ml
<b>3H5X14</b>	242 x 280	2546 ml

### H. 40 mm

<b>3H4X7</b>	120 x 140	509 ml
<b>3H4X8</b>	140 x 160	665 ml
<b>3H4X10</b>	175 x 200	1039 ml
<b>3H4X11</b>	195 x 220	1257 ml
<b>3H4X12</b>	210 x 240	1497 ml
<b>3H4X13</b>	235 x 255	1756 ml
<b>3H4X14</b>	245 x 280	2037 ml



## RECTANGULAR



### H. 50 mm

<b>11H5L24</b>	240 x 142	1704	ml
<b>11H5L26</b>	263 x 164	2157	ml
<b>11H5L28</b>	282 x 183	2580	ml
<b>11H5L30</b>	302 x 222	3352	ml
<b>11H5L36</b>	360 x 165	2970	ml
<b>11H5L38</b>	382 x 262	5004	ml
<b>11H5L39</b>	390 x 80	1751	ml
<b>11H5L40</b>	403 x 320	6448	ml

### H. 40 mm

<b>11H4L24</b>	243 x 142	1380	ml
<b>11H4L26</b>	263 x 164	1725	ml
<b>11H4L28</b>	282 x 183	2064	ml
<b>11H4L30</b>	302 x 222	2682	ml
<b>11H4L36</b>	360 x 165	2376	ml
<b>11H4L38</b>	382 x 262	4003	ml
<b>11H4L39</b>	390 x 80	1248	ml
<b>11H4L40</b>	403 x 320	5158	ml

## BIG RECTANGULAR



### H. 50 mm

<b>RETH5</b>	380 x 580	11020	ml
<b>11H5L56</b>	560 x 360	8280	ml
<b>11H5L59</b>	595 x 395	11751	ml

### H. 40 mm

<b>RETH4</b>	380 x 580	8816	ml
<b>11H4L56</b>	460 x 360	6624	ml
<b>11H4L59</b>	595 x 395	9401	ml

## FANCY



**H. 50 mm**

**23H5X25** 250 x 90 1125 ml

**23H5X30** 300 x 91 1365 ml

**23H5X35** 350 x 92 1610 ml

**H. 40 mm**

**23H4X25** 250 x 90 900 ml

**23H4X30** 300 x 91 1092 ml

**23H4X35** 350 x 92 1288 ml

## SPECIAL

Telaio regolabile in lunghezza ed in larghezza.  
Extendable st. steel frame, length and width adjustable.

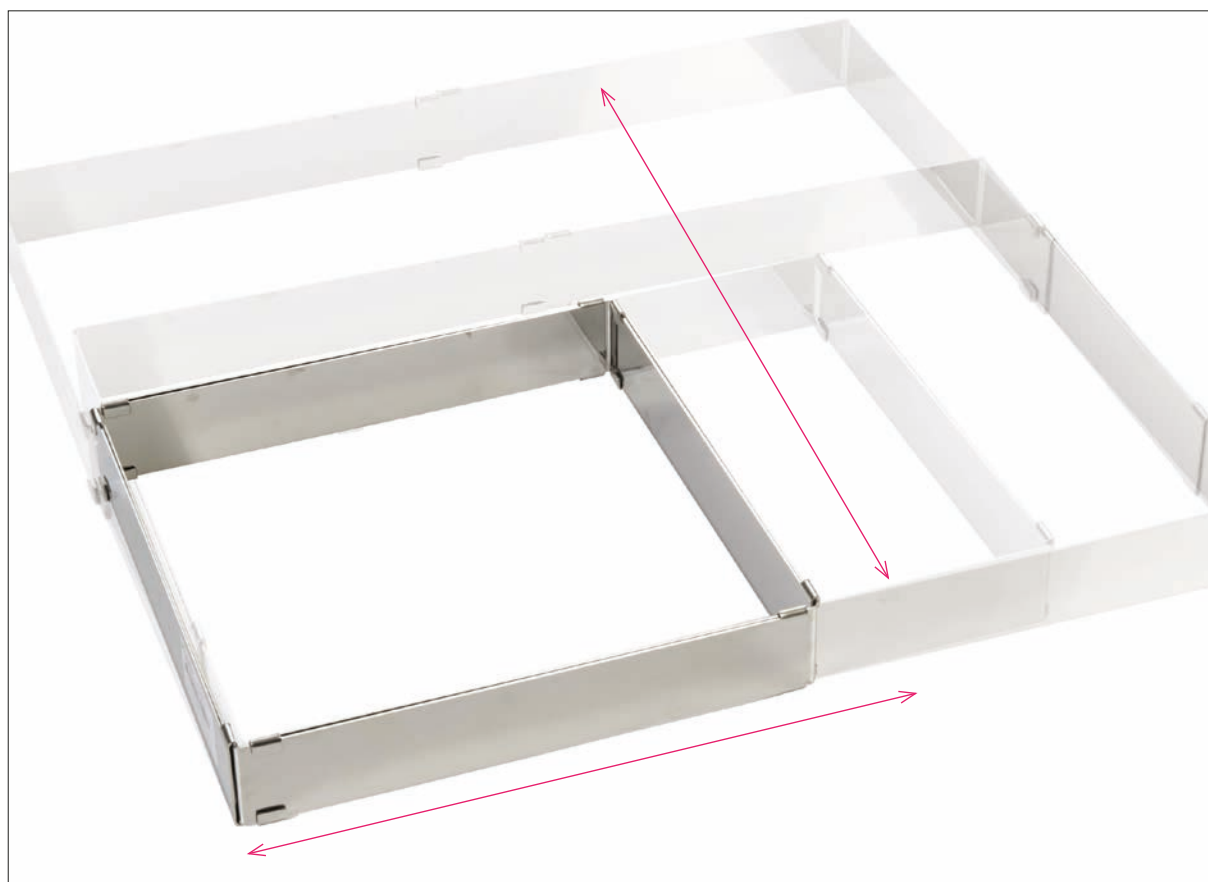

**H. 50 mm**

**RETSPECIAL 1** min. 305 x 305 - max 570 x 560

**H. 40 mm**

**RETSPECIAL 2** min. 305 x 305 - max 570 x 560

# Easter

## EGG

H. 40 mm

<b>27H4X12</b>	121 x 180	667	ml
<b>27H4X13</b>	134 x 200	823	ml
<b>27H4X14</b>	148 x 220	997	ml
<b>27H4X16</b>	161 x 240	1184	ml



## DOVE

H. 40 mm

<b>15H4X25</b>	236 x 132	840	ml
<b>15H4X30</b>	283 x 160	1209	ml
<b>15H4X34</b>	320 x 180	1560	ml



# Christmas

## TREE

H. 40 mm

<b>14H4X16</b>	153 x 128	371	ml
<b>14H4X20</b>	208 x 141	552	ml
<b>14H4X24</b>	245 x 180	950	ml
<b>14H4X30</b>	300 x 235	1408	ml



## COMET

H. 40 mm

<b>13H4X15</b>	158 x 68	245	ml
<b>13H4X23</b>	248 x 98	531	ml
<b>13H4X30</b>	320 x 133	882	ml



## ROUND

H. 60 mm

**70H602** kit 2 pcs Ø 100 - 120

H. 40 mm

**70H402** kit 2 pcs Ø 100 - 120

## SQUARE

H. 60 mm

**71H602** kit 2 pcs 100 x 100 - 120 x 120

H. 40 mm

**71H402** kit 2 pcs 100 x 100 - 120 x 120



# NUMBERS CAKE



## H. 30 mm

Number	Size H.300 mm	Cod. Code	Cap. ml
0	300x160h40	40H4X10	1900
1	300x93 h 40	40H4X01	1200
2	300x160h40	40H4X02	1800
3	300x160h40	40H4X03	1650
4	300x170h40	40H4X04	1750
5	300x160h40	40H4X05	1800
6	300x160h40	40H4X06	1950
7	300x160h40	40H4X07	1350
8	300x160h40	40H4X08	2000
9	300x160h40	40H4X09	1950

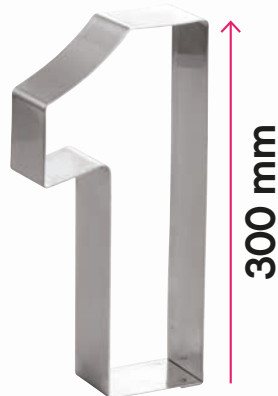

## H. 20 mm

Number	Size H.200 mm	Cod. Code	Cap. ml
0	200x160h40	30H4X10	850
1	200x93 h 40	30H4X01	520
2	200x160h40	30H4X02	800
3	200x160h40	30H4X03	740
4	200x170h40	30H4X04	780
5	200x160h40	30H4X05	800
6	200x160h40	30H4X06	870
7	200x160h40	30H4X07	600
8	200x160h40	30H4X08	900
9	200x160h40	30H4X09	870

# SPECIALE NATALE CHRISTMAS SPECIAL

Stampi pandoro in alluminio 10/10  
Aluminium 10/10 pandoro moulds

250 gr  
**30SP0250**  
Ø 16,5 h 13 cm

500 gr  
**30SP0500**  
Ø 19,5 h 14,5 cm

750 gr  
**30SP0750**  
Ø 20,5 h 15,5 cm

1000 gr  
**30SP1000**  
Ø 23 h 17 cm



100 gr  
**30SP0100**  
Ø 10,8 h 8 cm



Stampo Casetta di Natale  
Gingerbread House Cutter

**30CH001**

Acciaio inox - Stainless steel  
120x138 h 140mm

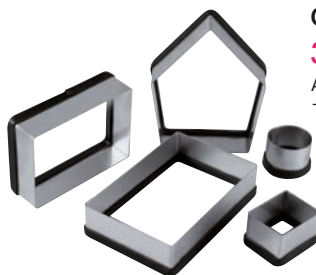

## GHIERA PER LIEVITATI

Realizzata con punte in acciaio inox, è adatta al contatto alimentare.

**Di facile impilamento sia su carrelli che su rastrelliere murali.**

Perfetto ancoraggio con tutti i tipi di stampi (colombe-stelle-cake-alberi etc..).

Impugnatura salda e sicura.

Ghiera in acciaio inox che permette una chiusura ottimale.

**Support with nails for leavened doughs**

Tips made of stainless steel and therefore suitable for food contact.

**Easy to stack both on trolleys and wall racks.**

Perfect adhesion on all types of moulds (colombe-stars-cake-trees etc..)

Firm and safe grip.

Stainless steel nail for optimal fastening.

Aghi girapanettoni lievitati  
Pin to turn "panettoni"

**53GP01** - 10 PCS

Spessore ago - Pin thickness: 2 mm

Lunghezza totale - Total length: 600 mm

Puntale perfettamente rifinito - Perfectly finished tip

Lunghezza puntale - Tip length: 8 mm

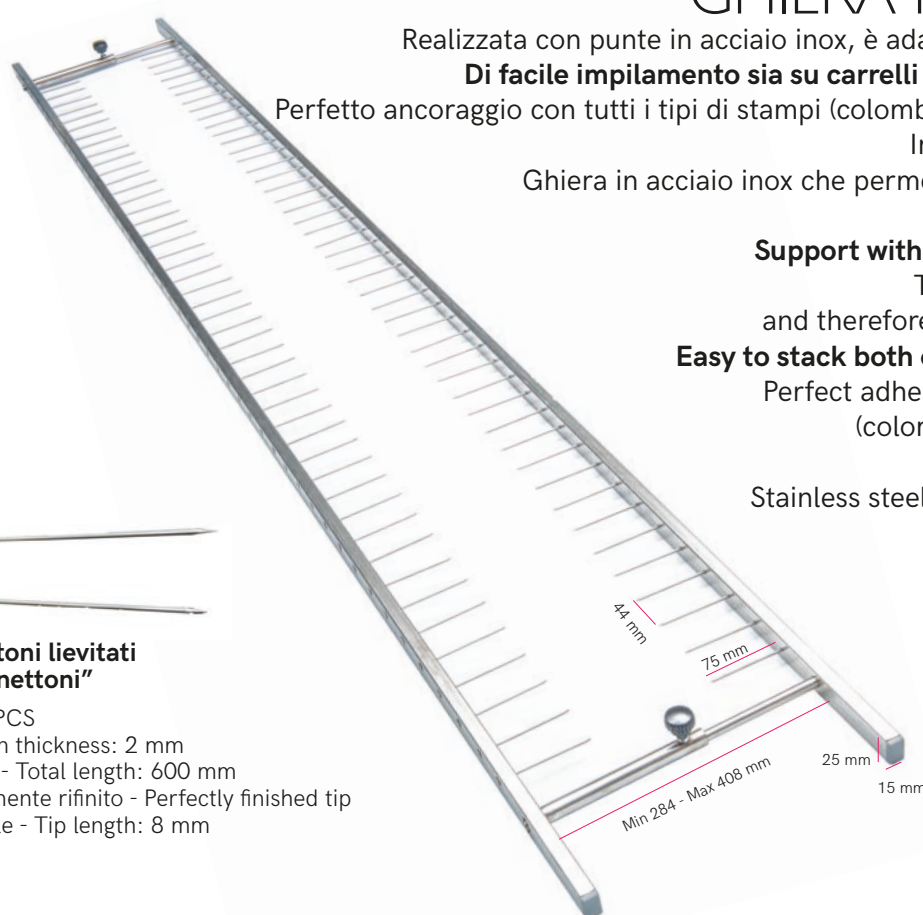

**50GIRA02**

Asse girapanettoni

"Panettoni" cake turning rod

Acciaio inox - Stainless steel

Lunghezza - Total size: 221 cm

Aghi fissi - fixed pins Ø2,7 mm



## LE COMPONENTI INOX

CAKE IDEA presenta un nuovo concetto di componibilità verticale, per consentire ai pasticceri più innovativi e creativi di offrire torte multigusto e multiconsistenza, sempre più sorprendenti, con preparazioni semplici e veloci. Gli stampi permetteranno una costruzione stratificata del dolce, grazie alla presenza di un top essenziale per la creazione con diverse consistenze e che funge anche da elemento decorativo, permettendo giochi di volumi.

CAKE IDEA presents a new concept of vertical modularity, to allow the most innovative and creative confectioners to offer multi-flavoured and multiconsistency cakes, more and more surprising, with simple and quick preparations. The moulds will allow a layered construction of the cake, thanks to the presence of a top essential for creating with different consistencies and which also acts as a decorative element, allowing games of volumes.



### Gli stampi dei CAMPIONI DEL MONDO

CAKE IDEA è stata protagonista dell'edizione 2020 della Coppa del Mondo della Gelateria. Le squadre in gara si sono contestate il titolo di Campioni del Mondo con le ultime novità del sistema di fasce inox componibili, grazie alle quali è possibile dare forma alla creatività.

### The moulds of the WORLD CHAMPIONS

CAKE IDEA was the protagonist of the 2020 edition of the Ice Cream World Cup. The participating teams competed for the title of World Champion with the latest innovations in the system of modular stainless steel bands, thanks to which it is possible to give shape to creativity.



## ELLIPSE

### 52KIT27

KIT COMPONENTI

Pack 3 pcs

Base: 27x12 h3 cm

Insert: 25x10 h2 cm

Top: 23x8 h2 cm

Cap. 1100 ml



## 4 TASTE

**38H4X22S**

4 Moulds: 10x10 h4 cm  
Pack 4 pcs  
Cap. 1600ml



## 4 TASTE KIT

**38KITH4X22**

Pack 9 pcs  
4 Insert: 8x8 h2 cm  
4 Moulds: 10x10 h4 cm  
1 Base: 22x22 h2 cm  
Cap. 1600ml

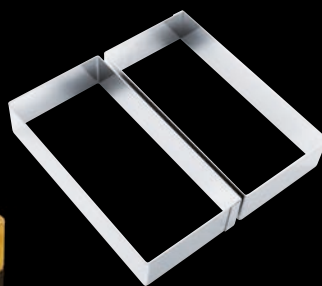

## DOUBLE

**37H4X22S**

2 Moulds: 10x20 h4 cm  
Pack 2 pcs  
Cap. 1600ml

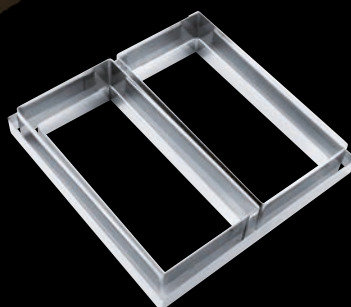

## DOUBLE KIT

**37KITH4X22**

Pack 5 pcs  
2 Insert: 18x8 h2 cm  
2 Moulds: 10x20 h4 cm  
1 Base: 22x22 h2 cm  
Cap. 1600ml



## DEMI 18

### 39H4X20S

Mould: Ø18 h4 cm  
Pack 2 pcs  
Cap. 985ml

### 39KITH4X20

KIT COMPONIBILI  
Pack 6 pcs  
Insert: Ø16 h2 cm  
Mould: Ø18 h4 cm  
Base: Ø20 h2 cm  
Cap. 985ml



## DEMI 22

### 39H4X24S

Mould: Ø22 h4 cm  
Pack 2 pcs  
Cap. 1473ml

### 39KITH4X24

KIT COMPONIBILI  
Pack 6 pcs  
Insert: Ø20 h2 cm  
Mould: Ø22 h4 cm  
Base: Ø24 h2 cm  
Cap. 1473ml

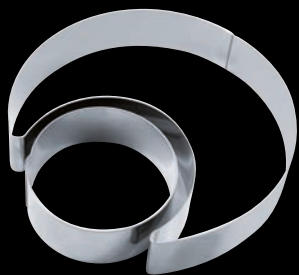

## MOON

### 36H4X22S

2 Moulds: Ø20 h4 cm  
Pack 2 pcs  
Cap. 1100ml



## MOON KIT

### 36KITH4X22

Pack 5 pcs  
2 Inserts: Ø28 h2 cm  
2 Moulds: Ø20 h4 cm  
1 Base: Ø22 h2 cm  
Cap. 1100ml





DUETTO 19

**33H4X20S**  
2 Moulds: Ø19 h4 cm  
Pack 2 pcs  
Cap. 950ml

DUETTO 23

**33H4X24S**  
2 Moulds: Ø23 h4 cm  
Pack 2 pcs  
Cap. 1400ml



DUETTO 19 KIT

**33KITH4X20**  
2 Insert: Ø17 h2 cm  
2 Moulds: Ø19 h4 cm  
2 Base: Ø22 h2 cm  
Cap. 950ml

DUETTO 23 KIT

**33KITH4X24**  
2 Insert: Ø21 h2 cm  
2 Moulds: Ø23 h4 cm  
2 Base: Ø25 h2 cm  
Cap. 1400ml



HEART 14

**35H4X14S**  
2 Moulds: 14x14 h4 cm  
Pack 2 pcs  
Cap. 530ml

HEART 19

**35H4X19S**  
2 Moulds: 19x19 h4 cm  
Pack 2 pcs  
Cap. 1000ml



HEART 19 KIT

**35KITH4X19**  
2 Insert: 15x8 h2 cm  
2 Moulds: 19x19 h4 cm  
Cap. 1000ml



## TWINS 16

### 34H4X16S

2 Moulds: 16x16 h4 cm  
Pack 2 pcs  
Cap. 950ml

## TWINS 20

### 34H4X20S

2 Moulds: 20x20 h4 cm  
Pack 2 pcs  
Cap. 1400ml



## TWINS 16 KIT

### 34KITH4X16

2 Insert: 13x13 h2 cm  
2 Moulds: 16x16 h4 cm  
2 Base: 17x17 h2 cm  
Cap. 950ml

## TWINS 20 KIT

### 34KITH4X20

2 Insert: 16x16 h2 cm  
2 Moulds: 20x20 h4 cm  
2 Base: 24x24 h2 cm  
Cap. 1400ml



## TRILOGY 18

### 32H4X18S

3 Moulds: Ø18 h4 cm  
Pack 3 pcs  
Cap. 950ml

## TRILOGY 22

### 32H4X22S

3 Moulds: Ø22 h4 cm  
Pack 3 pcs  
Cap. 1400ml



# CLASSIC SYSTEM



Barre in plastica per la produzione, sia dolce che salata, di monoporzioni e mignon. Il materiale rigido conferisce stabilità per una maggior precisione nella preparazione e maneggiabilità durante la lavorazione. Facili da riempire, anche senza teglia, e da spatolare per la chiusura. L'estrazione risulta facile anche con il prodotto non completamente congelato e grazie all'acetato non sarà necessario glassare.

Plastic bars for the production, both sweet and savoury, of single portions and mignons. The rigid material gives stability for greater precision in preparation and handling during processing. Easy to fill, even without baking tray, and to spatulate for closing. Extraction is easy even when the product is not completely frozen and thanks to acetate there is no need to glaze.



**Kit completo**  
**Complete kit**

L'articolo include vassoio e barre  
The article includes tray and bars

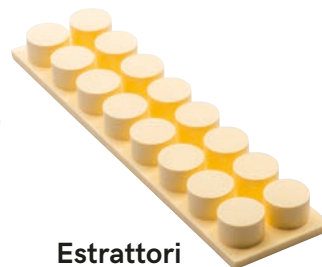

**Estrattori**  
**Extractors**

Non inclusi  
Not included



**Tagliapasta**  
**Cutters**

Non inclusi  
Not included



# MIGNON

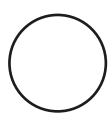

**CIRCLE**  
Ø 42,5 h 25 mm  
CAP. 23 ML

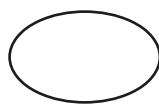

**OVAL**  
53x32 h 25 mm  
CAP. 33 ML

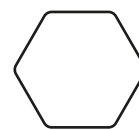

**EXAGONAL**  
46x41 h 25 mm  
CAP. 36 ML

Prod.	Codice - Code	Extractor	Cutter
32	MIGNON A001	ED 1	TPM 1
48	MIGNON B001	ED 1	TPM 1
96	MIGNON C001	ED 1	TPM 1

Prod.	Codice - Code	Extractor	Cutter
32	MIGNON A002	ED 2	TPM 2
48	MIGNON B002	ED 2	TPM 2
96	MIGNON C002	ED 2	TPM 2

Prod.	Codice - Code	Extractor	Cutter
32	MIGNON A003	ED 3	TPM 3
48	MIGNON B003	ED 3	TPM 3
96	MIGNON C003	ED 3	TPM 3



**SQUARE**  
37x37 h 25 mm  
CAP. 24 ML



**HEART**  
48x44 h 25 mm  
CAP. 35 ML



**COMMA**  
55x35 h 25 mm  
CAP. 32 ML

Prod.	Codice - Code	Extractor	Cutter
32	MIGNON A005	ED 5	TPM 5
48	MIGNON B005	ED 5	TPM 5
96	MIGNON C005	ED 5	TPM 5

Prod.	Codice - Code	Extractor	Cutter
32	MIGNON A007	ED 7	TPM 7
48	MIGNON B007	ED 7	TPM 7
96	MIGNON C007	ED 7	TPM 7

Prod.	Codice - Code	Extractor	Cutter
32	MIGNON A009	ED 9	TPM 9
48	MIGNON B009	ED 9	TPM 9
96	MIGNON C009	ED 9	TPM 9

**MIGNON A**  
**20X40CM**  
2 Barre/Moulds  
32 mignon

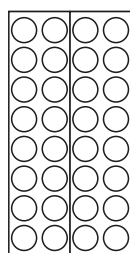

**MIGNON B**  
**30X40CM**  
3 Barre/Moulds  
48 mignon

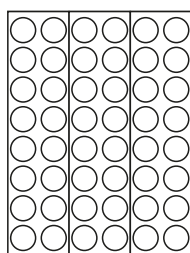

**MIGNON C**  
**60X40CM**  
6 Barre/Moulds  
96 mignon

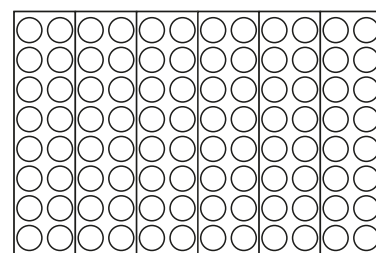



# INDIVIDUAL DESSERT

**MONOP. A**

**17X40CM**

2 Barre/Moulds

10 monoportion

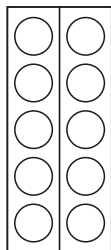

**MONOP. B**

**26X40CM**

3 Barre/Moulds

15 monoportion

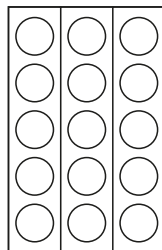

**MONOP. C**

**60X40CM**

7 Barre/Moulds

35 monoportion

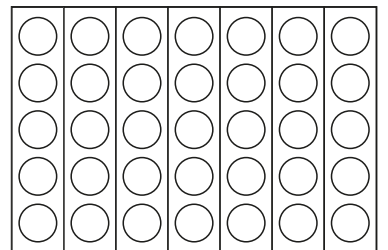

**Kit completo**  
**Complete kit**

L'articolo include vassoio e barre  
The article includes tray and bars



**Estrattori**  
**Extractors**

Non inclusi  
Not included



**Tagliapasta**  
**Cutters**

Non inclusi  
Not included

## CIRCLE

Ø65 h.40 mm

CAP. 133 ML

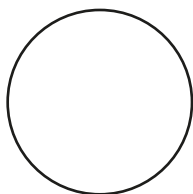

Prod.	Codice - Code	Extractor	Cutter
10	MONOP. A001	EM 1	TPG 1
15	MONOP. B001	EM 1	TPG 1
35	MONOP. C001	EM 1	TPG 1

## CIRCLE

Ø60 h 45 mm

CAP. 127 ML

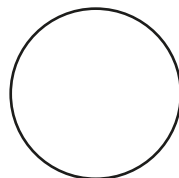

Prod.	Codice - Code	Extractor	Cutter
10	MONOP. A1	EM 01	TPG 01
15	MONOP. B1	EM 01	TPG 01
35	MONOP. C1	EM 01	TPG 01

## OVAL

87x51 h 40 mm

CAP. 139 ML

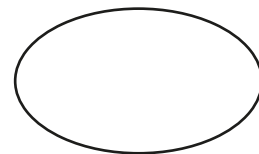

Prod.	Codice - Code	Extractor	Cutter
10	MONOP. A002	EM 2	TPG 2
15	MONOP. B002	EM 2	TPG 2
35	MONOP. C002	EM 2	TPG 2

## SQUARE

59x59 h 40 mm

CAP. 139 ML

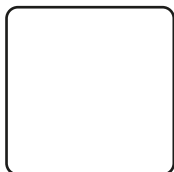

Prod.	Codice - Code	Extractor	Cutter
10	MONOP. A005	EM 5	TPG 5
15	MONOP. B005	EM 5	TPG 5
35	MONOP. C005	EM 5	TPG 5

## HEART

78,5x72,5 h 40 mm

CAP. 143 ML

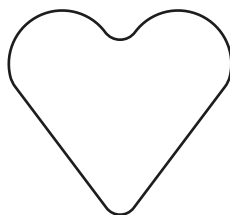

Prod.	Codice - Code	Extractor	Cutter
10	MONOP. A007	EM 7	TPG 7
15	MONOP. B007	EM 7	TPG 7
35	MONOP. C007	EM 7	TPG 7

## DROP

89x57,5 h 40 mm

CAP. 138 ML

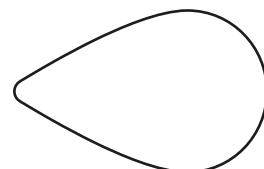

Prod.	Codice - Code	Extractor	Cutter
10	MONOP. A008	EM 8	TPG 8
15	MONOP. B008	EM 8	TPG 8
35	MONOP. C008	EM 8	TPG 8

## COMMA

92x60 h 40 mm

CAP. 143 ML

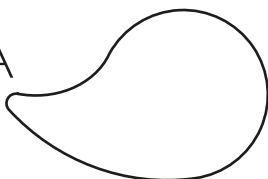

Prod.	Codice - Code	Extractor	Cutter
10	MONOP. A009	EM 9	TPG 9
15	MONOP. B009	EM 9	TPG 9
35	MONOP. C009	EM 9	TPG 9

## OBLONG

94x38 h 40 mm

CAP. 130 ML



Prod.	Codice - Code	Extractor	Cutter
10	MONOP. A0013	EM 13	TPG 13
15	MONOP. B0013	EM 13	TPG 13
35	MONOP. C0013	EM 13	TPG 13



# CAKE SLICE

SLICE 150 ML  
117x62 h 40 mm



Prod.	Codice - Code	Extractor	Cutter
8	MONOP. A0016	EM 16	TPG 16
12	MONOP. B0016	EM 16	TPG 16
28	MONOP. C0016	EM 16	TPG 16

12 fette/slices = 1 torta/cake Ø24cm  
L'articolo include vassoio e barre  
The article includes tray and bars



# SPECIAL SIZE

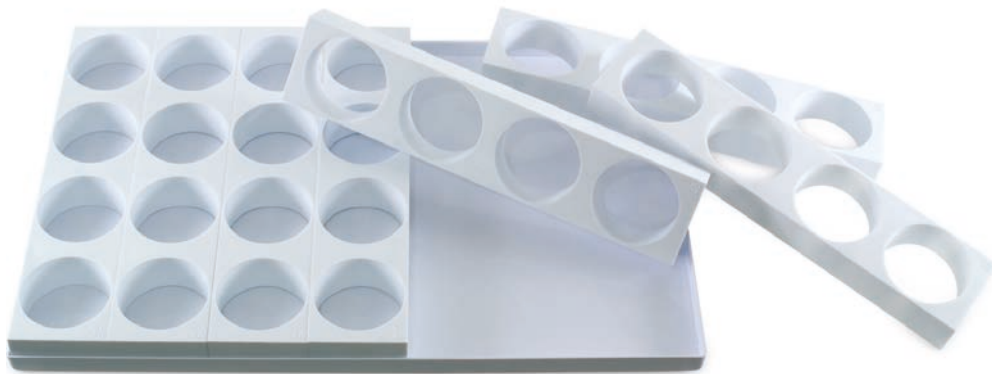

Stampi per **monoporzioni extra size** per rispondere alle esigenze di misure diverse dall'ordinario. L'articolo include vassoio 60x40 cm e 7 barre.

Moulds for extra-size single-portion to meet the needs of non-standard sizes. The item includes 60x40 cm tray and 7 bars.

Prod. 28 dolci / cake

ml	mm	h mm	Cod.	Cutter
200	Ø 80	40	EXTRA C	TPEX 1



Stampi per pratici **mini cake biporzione** adatti alle richieste delle moderne tendenze.

L'articolo include vassoio 60x40 cm e 5 barre.

Moulds for practical mini double portion cakes suitable for modern trends' demands.

The article includes 60x40 cm tray and 5 moulds

Prod. 15 dolci / cake

ml	mm	h mm	Cod.	Cutter
350	Ø 100	45	MONOP. C101	TPB1

# ACETATI - ACETATE

Extra trasparenti, super resistenti, prodotti con materiale di alta qualità. Facili da usare per rivestire stampi e per realizzare e sformare monoporzioni e mignon. Antiaderenti per uso alimentare. Adatti al raffreddamento in abbattitore, congelatore e frigo, ma non adatti alla cottura.

Extra-clear, super-strong, made of high-quality material. Easy to use for coating moulds and for making and unmoulding monoportions and mignons. Non-stick for food use. Suitable for cooling in blast chillers, freezers and fridges, but not suitable for baking.

## NASTRI - RIBBONS



h (mm)	Codice - Code
h 25	<b>NSA H 25</b>
h 30	<b>NSA H 30</b>
h 35	<b>NSA H 35</b>
h 40	<b>NSA H 40</b>

h (mm)	Codice - Code
h 45	<b>NSA H 45</b>
h 50	<b>NSA H 50</b>
h 55	<b>NSA H 55</b>
<b>h 60</b>	<b>NSA H 60</b>

### Specifiche / features

spessore / thickness  
80 my

lunghezza  
length 305 mt



anima / core  
Ø 70 mm

misura esterna  
external size  
Ø 210 mm

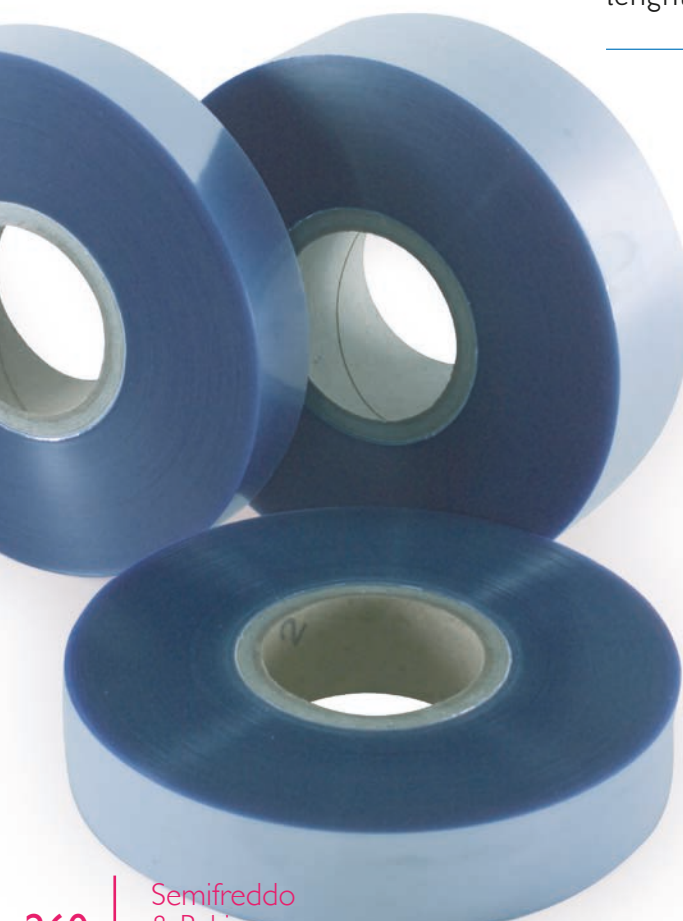

Il materiale multistrato con il quale sono realizzati i nostri nastri proviene parzialmente da plastica riciclata. La loro speciale composizione li rendono idonei al contatto alimentare e rispettosi dell'ambiente.

The multi-layer material with which our ribbons are made comes partly from recycled plastic. Their special composition makes them suitable for food contact and environment-friendly.



Tutti i rotoli sono adatti alla taglianastri  
All ribbons are suitable for ribbon cutter

**50MC001**

**MART  
CUTTER**  
AUTOMATIC RIBBON CUTTER



## FOGLI CHITARRA - GUITAR SHEETS

---



Ideali per creare decorazioni di cioccolato, trasferiscono lucentezza al prodotto finito e facilitano il distacco.  
Ideal for creating chocolate decorations as they transfer shine to the finished product and facilitate the detachment.

### **NSA60X40MO**

590x390 mm  
Pack 50 pcs - 120 my

### **NSA39X39MO**

390x390 mm  
Pack 100 pcs - 75 my

### **NSA27X27MO**

270x270 mm  
Pack 100 pcs - 75 my  
ideal for 50TLMINI

## FOGLI - SHEETS

---

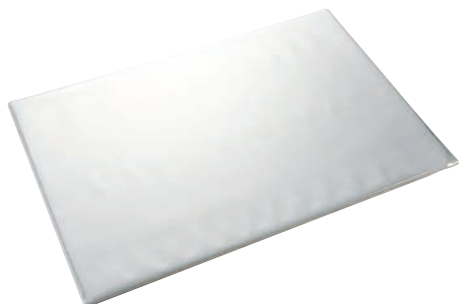

80 my - 50 pcs  
Disponibili altre misure e spessori su richiesta.  
On request other sizes and thicknesses.

### **NSA400X600**

388x588 mm

### **NSA300X300**

300x300 mm

## STRISCE - STRIPS

---



90 my - 1000 pcs

### **NSA30X240**

h 30x240 mm

### **NSA40X240**

h 40x240 mm

### **NSA25X150**

h 25x150 mm



## LA TRADIZIONE CREA LA MODERNITÀ

Combinare gli elementi per dare vita a monoporzioni che, giocando con le proporzioni dei sapori, creano nuove armonie di gusto. Nasce con questo intento un progetto di dessert, pensato per la ristorazione, ma perfetto per la pasticceria moderna, che utilizzando semplici attrezzature consente risultati di alto livello.

Monoporzioni che accostano gusti, consistenze e colori per stimolare la voglia di assaggiare dei clienti, combinandoli a misure e forme diverse.

## TRADITION CREATES MODERNITY

Combining the elements to give life to single portions that, playing with the proportions of flavors, create new harmonies of taste. With this intent a dessert project was born, designed for catering, but perfect for modern pastry making, which by using simple equipment allows high level results.

Monopotions that combine flavors, textures and colors to stimulate customers' desire to taste, combining them with different sizes and shapes.



Circle

**3OIDEA01**

Ø83 h 25mm ~ 130ml  
Prod. 12 pcs  
3 barre-bars + 1 estrattore-extractor



Tagliapasta - Cutter

**TPIDEA01**

2 pcs - 2 sizes



Rectangle

**3OIDEA02**

62x48 h 25mm ~ 70ml  
Prod. 18 pcs  
3 barre-bars + 1 estrattore-extractor



Tagliapasta - Cutter

**TPIDEA02**

2 pcs - 2 sizes



Log

**3OIDEA03**

118x47 h 25mm ~ 130ml  
Prod. 9 pcs  
3 barre-bars + 1 estrattore-extractor



Tagliapasta - Cutter

**TPIDEA03**

2 pcs - 2 sizes



Triangle

**3OIDEA04**

42x38 h 25mm ~ 25ml  
Prod. 48 pcs  
3 barre-bars + 1 estrattore-extractor



Dot

**3OIDEA05**

Ø35 h 25mm ~ 25ml  
Prod. 48 pcs  
3 barre-bars + 1 estrattore-extractor



Square

**3OIDEA06**

31,5x31,5 h 25mm ~ 25ml  
Prod. 48 pcs  
3 barre-bars + 1 estrattore-extractor

Ogni confezione comprende:  
3 barre ed 1 estrattore.



# EASY LOG



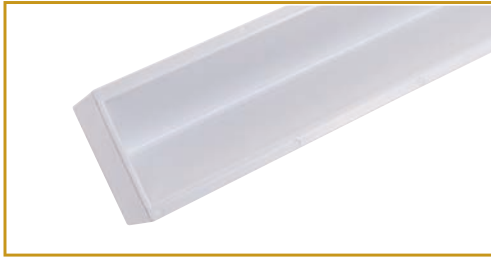

## CLASSIC



**30TT104S**  
400x100 - h60 mm



## DOME



**ST2**  
480x65 - h50 mm

**ST4**  
480x50 - h40 mm

### ACCESSORI - ACCESSORIES



#### Stampi per inserti/Moulds for inserts

#### **30TB3S**

Kit 2 stampi plastica/2 plastic moulds kit  
35x180 h30 mm



#### **Pralina Stella**

#### **MA1984**

Polycarbonate mould  
40x42 h16 mm  
15 pcs ~ 10 gr

# SEMIFREDDO MATS

360x163 mm  
FOR CLASSIC MOULD

I tappeti in silicone sapranno arricchire i vostri tronchetti.  
Il materiale rende possibile un'ottimale sformatura del semifreddo  
donando al dessert decori di grande effetto.

The silicone mats will enrich your log-shaped dessert.  
The material features ensure easy removal of the semifreddo from the  
mould, creating impressive decorations.

LISCIO/SMOOTH  
30TS000



ARABIC  
30TS001



FLOREAL  
30TS002



O'CLOCK  
30TS003



MEDIEVAL  
30TS005



STONE  
30TS006

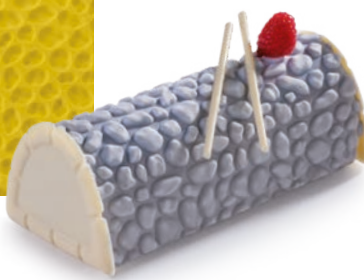

WAVES  
30TS007

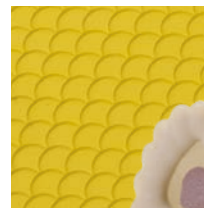

**HOLLY**  
30TS008



**SNOWFLAKE**  
30TS009



**COMET**  
30TS010



**BRICK**  
30TS012



**QUADRI**  
30TS016



## DECORATIONS

Kit 2 plastic moulds to realize 12 decorations

**ARABIC**  
20TES001



**FLOREAL**  
20TES002



**FLOWER**  
20TES004



**MEDIEVAL**  
20TES005



**STONE**  
20TES006



**WAVES**  
20TES007





# ICE CREAM

# Ice Tube

Lo stampo best seller per rinfrescare l'estate. Con Ice Tube si ottengono splendidi ghiaccioli da esporre in vetrina per ingolosire i clienti e da consegnare loro come contenitore. Riutilizzabili e lavabili in lavastoviglie: 50 lavaggi, 100% riciclabile, BPA free.

The best seller mould to refresh the summer. With Ice Tube you can obtain wonderful icicles to display in the window to tempt customers and to give them as a container. Reusable and dishwasher safe: 50 washes, 100% recyclable, BPA free.





**Ice tube**  
**CLP01**  
 100 pcs ~150 ml  
 Ø53 x 174 mm

## PLEXIGLASS DISPLAYS



**Supporto plastica bianca per abbattitore**  
**White plastic holder for blast chiller**  
**CLPESPOB**  
 290x390 h120 mm  
 28 sedi - holes



**Espositore trasparente vetrina verticale**  
**Transparent display for vertical cabinets**  
**CLPESPOBTRA**  
 280x360 h120 mm  
 25 sedi - holes



**Espositori satinati per vetrina gelato**  
**Satin-finish displays for standard ice-cream**  
**CLPESPO21**  
 250x360 h45 mm  
 21 sedi - holes

STECCO  MOULDS



Stampo in **silicone alimentare** per dolci da passeggio a forma di lingotto. Proposto con due diverse grammature consente di produrre gelati e mini snack, ricoperti per diventare ancora più golosi.

**Food grade silicone** mould for ice creams on stick in the shape of an ingot. Proposed with two different weights allows you to produce ice cream and mini snacks, that once covered become even more delicious.



## BRICK

**104002**

Ice cream: 35 x 25 h 93 mm  
Prod. 12 pcs - Weight ~ 74 ml

2 Stampi/moulds 390 x 146 mm  
Vassoio/tray 410 x 305 mm  
50 Bastoncini/sticks



## DISPLAY

**10E007**

370x230 h 50 mm - Cap. 24 pcs  
Ideal for Brick

**10E006**

370x235 h 39 mm - Cap. 40/48 pcs  
Ideal for Brick Mini

## BRICK MINI

**104003**

Ice cream: 26,5 x 21 h 70 mm  
Prod. 16 pcs - Weight ~ 35 ml

2 Stampi/moulds 390 x 118 mm  
Vassoio/tray 410 x 255 mm  
50 Bastoncini/sticks



## STICKS

**10SL114**

9,5 h 114 mm - 500 pcs  
Ideal for Brick

**10SL072**

8 h 72 mm - 500 pcs  
Ideal for Brick Mini

STECCO  MOULDS



Lo **stampo in silicone** perfetto per realizzare ricoperti o semplici gelati su stecco.  
La sua forma classica e lineare consente di creare infinite proposte, sia dolci che salate.

**Classic silicone mould** to prepare covered or simple ice creams on a stick.  
Its linear shape allows to create endless proposals, both sweet and savory.



## CLASSIC

**104000**

Ice-cream: 44x22 h 93 mm  
Prod: 12 pcs - 80 ml

2 Stampi/Moulds 390x146 mm  
Vassoio/Tray 410x310 mm  
50 Bastoncini/Sticks



## DISPLAY

**10E007**

370x230 h 50 mm - Cap. 24 pcs  
Ideal for Classic

**10E006**

370x235 h 39 mm - Cap. 40/48 pcs  
Ideal for Classic Mini



## CLASSIC MINI

**104001**

Ice-cream: 33x18 h 69 mm  
Prod: 16 pcs - 35 ml

2 Stampi/Moulds 390x118 mm  
Vassoio/Tray 410x255 mm  
50 Bastoncini/Sticks



## STICKS

**10SL114**

9,5 h 114 mm - 500 pcs  
Ideal for Classic

**10SL072**

8 h 72 mm - 500 pcs  
Ideal for Classic Mini

# GhiaccioloFlex

La rivoluzione dedicata alla produzione artigianale di ghiaccioli su stecco. Lo straordinario materiale plastico utilizzato per la sua produzione lo rende particolarmente flessibile e assolutamente indeformabile.

The revolution dedicated to the artisan production of ice lollies on stick. The extraordinary plastic material selected and used for its production makes it absolutely non-deformable and particularly flexible.





## WAVE

105000

86 ml

49x22 h 125 mm

Prod: 24 pcs ~ 80/85 gr



## RECOUVERT

105002

90 ml

56x33 h 102 mm

Prod: 24 pcs ~ 80/85 gr



## TWIG

105003

90 ml

Ø35 h 100 mm

Prod: 24 pcs ~ 80/85 gr

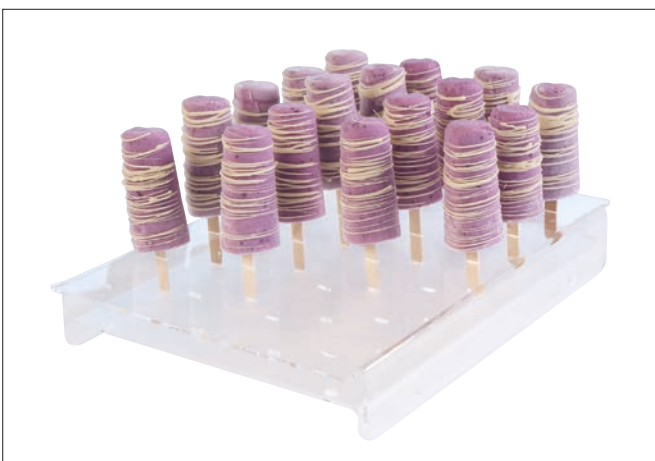

**Espositore in plexiglass per vetrina orizzontale**  
**Plexiglass display for horizontal showcases**

10-E002

Misura - Size: 360x250 h50mm

Cap. 24 pcs

# Baby Ice®

Un ottimale connubio di simpatia delle forme e genuinità degli ingredienti che solo la vera produzione artigianale può offrire. Grazie agli stampi in plastica a forma di animali si potranno produrre coloratissimi e freschissimi ghiaccioli. Lavabili in lavastoviglie e riutilizzabili.

The perfect mix of funny shapes and genuine ingredients that can be provided only by artisan production. A kit of plastic moulds to produce colorful and fresh animal shaped ice lollies. Reusable and dishwasher safe.



Cow x10 pcs  
65x33 h90mm

Bear x10 pcs  
66x28 h87mm

Cat x10 pcs  
61x35 h89mm

Mouse x10 pcs  
60x35 h80mm

Dog x10 pcs  
74x29 h90mm

Pig x10 pcs  
53x37 h87mm

Hippo x10 pcs  
68x31 h95mm

Chick x10 pcs  
85x33 h90mm

## SBIKIT01

80 pcs (8 mod.x10 pcs)  
bastoncini inclusi - stick included

## BST100

Sticks 100 pcs (mix)



## PLEXIGLASS DISPLAYS

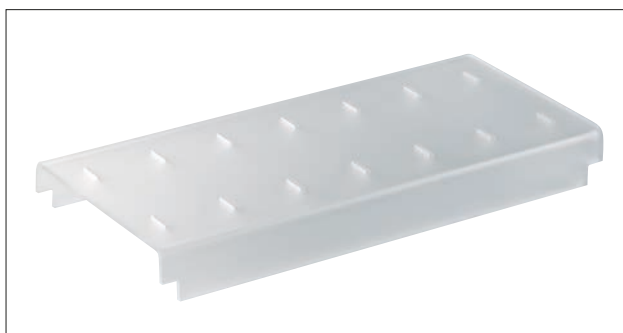

**Espositore per vetrina orizzontale**  
**Display for horizontal showcases**

### ESPICE14

Size: 160x360 h35 mm  
Cap. 14 pcs



L'equilibrato mix di caratteristiche che rendono questo prodotto unico nel suo genere sono: funzionalità, praticità, eleganza e versatilità. Lo stampo, dopo la produzione, diventa un sistema di esposizione in vetrina o negli eleganti banchetti. Ideale per la realizzazione di dolci semifreddi o stuzzicanti aperitivi. Lavabili in lavastoviglie e riutilizzabili.

The balanced mix of features that make this product unique are: functionality, practicality, elegance and versatility. After production, the mould becomes a display system in the showcase or in elegant banquets. Ideal for making semifreddo desserts or tasty appetizers. Reusable and dishwasher safe.



**TONDI -  
ROUNDS**

**GST01**

100 pcs  
Ø40 h 188mm ~ 90ml



**MINI**

**GST10**

100 pcs  
Ø35 h 196mm ~ 50ml

## PUSH UP POPS DISPLAYS



**Supporto plastica bianca per abbattitore  
White plastic holder for blast chiller**

**GSTESPOB**

310x400 h90 mm  
28 sedi - holes

# Black & White

IL TUO STILE INVETRINA  
YOUR STYLE IN THE SHOP WINDOW



Vaschette porta gelato conferiscono un tocco di modernità all'interno delle gelaterie.  
Le nuove vaschette in plastica bianca o nera sono un'originale alternativa all'acciaio e danno risalto ai colori del gelato.  
Possono essere personalizzate con il vostro logo, sono resistenti agli urti e sono lavabili in lavastoviglie.  
Personalizzabili con logo.

Ice cream basins to give a touch of modernity inside the ice cream parlors.  
The new white and black plastic basins are an original alternative to steel and they will emphasize the colors of ice cream. They can be customized with your logo, are shock resistant and dishwasher safe. Customizable with logo.



25 x 36 h 8 cm - **3,6 L**

Bianco - White  
**AG36258POLB**

Nero - Black  
**AG36258POLN**



25 x 36 h 12 cm - **5,8 L**

Bianco - White  
**AG362512POLB**

Nero - Black  
**AG362512POLN**



## ACCESSORI PER VASCHE BASINS ACCESSORIES



**Portaconi piccoli**  
**Small ice cream holders**

**AG09002**

Cap. 27 pcs  
Misure/Size: 350x140 h52 mm  
Fori/Holes: Ø18mm



**Portaconi piccoli**  
**Small ice cream holders**

**AG09003**

Cap. 45 pcs  
Misure/Size: 350x223 h52 mm  
Fori/Holes: Ø18mm

# ICE CREAM SPATULAS

Una linea completa di spatole per dare un tocco di colore alle vetrine gelato. Disponibili in vari colori, nelle versioni classica o per carapina, le spatole Martellato sono interamente made in Italy. I materiali sono di alta qualità: cucchiaio in acciaio inox e manico ergonomico in plastica, personalizzabile su richiesta con scritte e loghi.

A complete line of spatulas to give a touch of color to the ice cream display cases. Available in different colors, in classic or carapina versions, Martellato spatulas are entirely made in Italy. The materials are of high quality: stainless steel spoon and ergonomic plastic handle, customizable on request with lettering and logos.



**Super confort, con impugnatura ergonomica.**  
**Super comfort, with ergonomic handle.**

## CLASSIC

Lunghezza totale/ Total length: 26cm  
Manico/ Handle: 13cm

**10SG00**  
Trasparente  
Transparent

**10SG01**  
Bianco  
White

**10SG04**  
Azzurro  
Sky Blue

**10SG05**  
Verde  
Green

**10SG06**  
Giallo  
Yellow

**10SG07**  
Nero  
Black

**10SG100**  
Finto legno  
Wood-like

## CARAPINA

Lunghezza totale/ Total length: 20cm  
Manico/ Handle: 10cm



**10SGC00**  
Trasparente  
Transparent

**10SGC01**  
Bianco  
White

**10SGC02**  
Lilla  
Lilac

**10SGC03**  
Rosa  
Pink

**10SGC05**  
Verde  
Green

**10SGC07**  
Nero  
Black

**10SGC100**  
Finto legno  
Wood-like

## FLUO



Lunghezza totale/ Total length: 27cm  
Manico/ Handle: 14cm



**SGM00**  
Trasparente  
Transparent



**SGM001**  
Arancio  
Orange



**SGM003**  
Bianco  
White



**SGM004**  
Giallo  
Yellow



**SGM007**  
Rosa  
Pink



**SGM008**  
Rosso  
Red



**SGM100**  
Finto legno  
Wood-like

## PORZIONATORI ICE CREAM SCOOPS



Ideali per realizzare palline di gelato di diverse dimensioni e grammature. I porzionatori a molla Martellato sono realizzati in acciaio inox e presentano un pratico manico rivestito in plastica isolante.

Ideal for making ice cream balls of different sizes and weights. The Martellato spring-loaded portioners are made of stainless steel and feature a practical handle covered in insulating plastic.

<b>1/65 Lt</b>	<b>1/40 Lt</b>	<b>1/30 Lt</b>	<b>1/24 Lt</b>	<b>1/20 Lt</b>
Ø 38 mm	Ø 44 mm	Ø 48 mm	Ø 50 mm	Ø 57 mm
<b>10PG01</b>	<b>10PG02</b>	<b>10PG03</b>	<b>10PG04</b>	<b>10PG05</b>

## CUCCHIAI SPOONS



I cucchiai in alluminio ultraleggero consentono una perfetta maneggiabilità.

The ultralight aluminum spoons allow perfect handling.

Cap. <b>30 gr</b>	Cap. <b>42 gr</b>	Cap. <b>60 gr</b>	Cap. <b>70 gr</b>
<b>10CG01</b>	<b>10CG02</b>	<b>10CG03</b>	<b>10CG04</b>

# SEGNAGUSTO - FLAVOUR MARKER

## IMMERSIONE - IMMERSION



### 10SI001B

Segnagusto in plexiglass ad immersione  
Immersion plexiglass flavour marker

150x70 mm bianco opalino/opaline white  
pack 10 pcs

### 10SI002B

Segnagusto in plexiglass ad immersione  
Immersion plexiglass flavour marker

180x84 mm bianco opalino/opaline white  
pack 10 pcs

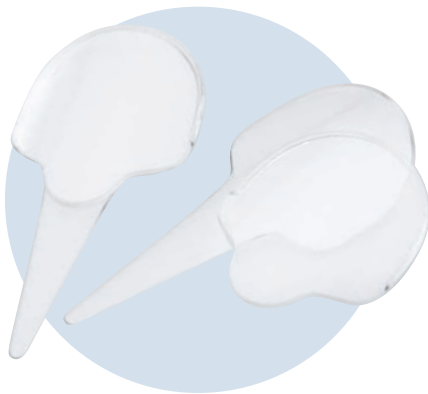

Supporti in plastica per segnagusto  
Plastic supports for ice-cream flavour

### 10SEG

Cartellini non inclusi/Labels not included  
kit 10 pcs - h 19 cm



Inserti neutri  
Neutral inserts

### 10SEG05

INSERTI NEUTRI PER SEGNAGUSTO 10SEG  
(supporti in plastica non inclusi)  
neutral inserts for plastic support 10SEG  
(plastic supports not included)  
kit 30 pcs



## APPOGGIO - FREE-STANDING



### 10SA001B

Segnagusto in plexiglass da appoggio  
Free-standing plexiglass flavour marker

85 x h 50,5 mm bianco opalino/opaline white  
pack 10 pcs

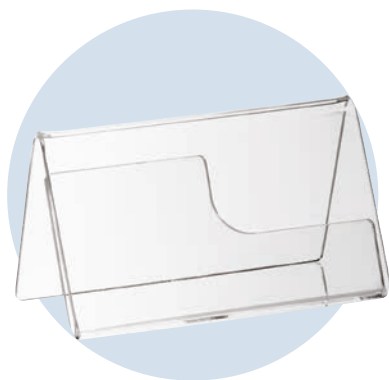

Porta cartellino in plastica  
Transparent plastic marker holder

### 10SEGB

Misure - Size: 87x52mm

Cartellini non inclusi/Labels not included

kit 10 pcs



Inserti neutri  
Neutral inserts

### 10SEG06

INSERTI NEUTRI PER SEGNAGUSTO 10SEGB  
(supporti in plastica non inclusi)

neutral inserts for plastic support 10SEGB  
(plastic supports not included)

kit 30 pcs

raschietti - scrapers

### RTRA1-5

Set 5 raschietti decorativi misti - Set composed of 5 different decorative scrapers

Misura - Size 14,5x15cm

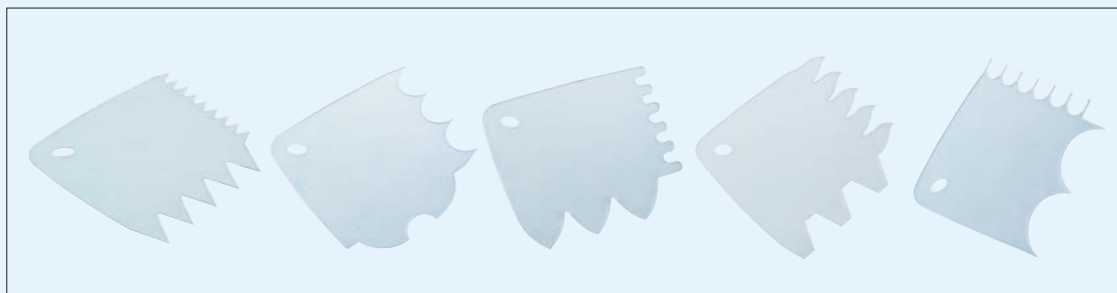

# DeepMeltinChoc

MADE IN ITALY

Scioglitore a secco pensato per le gelaterie, grazie alla sua forma e dimensione è ideale per coperture in cioccolato di gelati e semifreddi su stecco. Presentato con colorazione classica, che ricorda i toni del cioccolato per adattarsi ad ogni tipologia di arredo e per essere utilizzato direttamente sul banco. Le caratteristiche tecniche del scioglitore analogici, tra cui il termostato che consente di regolare la temperatura e la vasca estraibile in alluminio anodizzato per una più facile pulizia, fanno di DEEP-MELTINCHOC un articolo essenziale.

Dry melter designed for ice cream parlours, thanks to its shape and size it is ideal for chocolate coatings of ice creams and semifreddi on sticks. Presented with the classical colour that recalls chocolate to be adaptable to any type of environment and to be used straight on the counter. The technical features of the analogical melter, including the thermostat that allows the temperature to be adjusted and the removable anodised aluminium tank for easier cleaning, make DEEP-MELTINCHOC an essential item.



Scocca, coperchio e fondo in resistente materiale plastico  
Body, lid and bottom in durable plastic material

**1,7 L**

**Deep MeltinChoc**

**MC10**

Ø20,5 h21,2 cm



**Vaschetta - Basin**

**MC001001**

Vasca estraibile in alluminio anodizzato  
Removable basin in anodized aluminum  
Ø14 h18 cm



**Barattoli con coperchio**  
**Jars with lid**

Misura/size	Cod.
ø 20 h 8 cm	<a href="#">BA2008</a>
ø 20 h 15 cm	<a href="#">BA2015</a>
ø 20 h 20 cm	<a href="#">BA2020</a>
ø 20 h 25 cm	<a href="#">BA2025</a>
ø 20 h 30 cm	<a href="#">BA2030</a>

Misura/size	Cod.
ø 18 h 8 cm	<a href="#">BA1808</a>
ø 18 h 15 cm	<a href="#">BA1815</a>
ø 18 h 20 cm	<a href="#">BA1820</a>
ø 18 h 25 cm	<a href="#">BA1825</a>
ø 18 h 30 cm	<a href="#">BA1830</a>

Misura/size	Cod.
ø 15 h 8 cm	<a href="#">BA1508</a>
ø 15 h 15 cm	<a href="#">BA1515</a>
ø 15 h 20 cm	<a href="#">BA1520</a>

Misura/size	Cod.
ø 12 h 8 cm	<a href="#">BA1208</a>
ø 12 h 15 cm	<a href="#">BA1215</a>
ø 12 h 20 cm	<a href="#">BA1220</a>

Misura/size	Cod.
ø 10 h 8 cm	<a href="#">BA1008</a>
ø 10 h 15 cm	<a href="#">BA1015</a>
ø 10 h 20 cm	<a href="#">BA1020</a>



**Contenitore con mezzo coperchio ruotabile**  
**Container with rotating half lid**

[AG03720](#) - ø 20 x h 20 cm

[AG03730](#) - ø 20 x h 30 cm



**Contenitori multiuso**  
**Multipurpose container**

[AG01410](#) - 25 x 18,5 h 20 cm

[AG01420](#) - 30 x 18,5 h 30 cm

[AG01430](#) - 35 x 18,5 h 40 cm



**Reggi coni da banco satinato 3 sedi**  
**Glazed counter cones stand 3 holes**

**AG03000**

25 x 7,5 h 13 cm (Fori/Holes Ø 3,5 cm)



**Reggi coni da banco 3 sedi**  
**Counter cones stand 3 holes**

**AG03108**

24,5 x 8,5 h 13,5 cm (Fori/Holes Ø 3,5 cm)



**Reggi coni da banco 4 sedi**  
**Counter cones stand 4 holes**

14 x 14 h 24 cm (Fori/Holes Ø 3 cm)

**AG00208N**

**base nera/black base**

**AG00206N**

**base satinata/glazed base**



**Reggi coni da banco satinato**  
**Glazed counter cones stand**

**AG03206**

**3 sedi/holes** - 21x 9 h 13 cm (Fori/Holes Ø 3,5 cm)

**AG03306**

**4 sedi/holes** - 28,5 x 9 h 13 cm (Fori/Holes Ø 3,5 cm)



**Porta coni con divisorio estraibile**  
**Cones holder with removable partition**  
**AG04610**  
43 x 40 h 43 cm



**Porta coni con coperchio**  
**Cones holder with lid**  
**AG03650**  
30 x 37 h 32 cm



**Porta coni a tre vani tubolari con coperchi**  
**3-compartment tubular cones holder with lids**  
**AG03640**  
36 x 32,5 h 39 cm



**Porta coni 12 sedi/Cones holder 12 holes**  
33 x 25 h 50 cm (Fori/Holes Ø 3,5 cm)

**AG00908**

**base nera/black base**

**AG00906**

**base satinata/glazed base**

**AG00908P**

**base nera con porta/black base with door**

**AG00906P**

**base satinata con porta/glazed base with door**

# PLEXIGLASS ACCESSORIES



**Porta coni con cassetto estraibile**  
**Cones holder with removable drawer**

**AG00930**

25,5 x 18 h 60,5 cm



**Porta coni girevole 18 sedi**  
**Revolving cones holder 18 holes**

Ø 32 h 60cm cm (Fori/Holes Ø 3,5 cm)

**AG00708** - nero/black

**AG00706** - satinato/glazed

**AG00708P** - nero con porta/black with door

**AG00706P** - satinato con porta/glazed with door



**Porta coppette 3 scomparti**  
**Cups holder 3 compartments**

**AG00501**

30,5 x 11,5cm h 30 cm (int.: Ø 8, Ø 9, Ø 10 cm)



**Porta coppette con vano porta palette e tasca per cartellini / Cup holder with spoons compartment and pocket for tags**

**AG05301**

28 x 25 cm h 55 cm



**Contenitore porta palette**  
**Spons container**

**AG01701**

18,5 x 30 h 19 cm

**AG01801**

17 x 26 h 16 cm



**Contenitore porta palette**  
**Spons container**

**AG00606**

22 x 26 h 21 cm

**trasparente con fianchi satinati**  
**transparent with glazed sides**



**Contenitore multiuso**  
**Multipurpose container**

**AG01720** - 17,5 x 27 h 31 cm

**AG01710** - 12,5 x 18 h 20,5 cm



# SPECIAL EQUIPMENT



**3500 Lady's Kisses in 26 minutes**



# BALL SHAPING MACHINE

per Baci di Dama e Sfere  
*for Lady's Kisses and Spheres*

**EasySphere è lo strumento rivoluzionario che permette di produrre sfere di pasta perfette, abbattendo al massimo i costi di manodopera.**

Il sistema innovativo consente di realizzare sfere, con impasti di diverso tipo, riducendo di più del 50% i tempi di produzione rispetto al metodo manuale, con risultati a dir poco eccellenti. Grazie al rullo interno è possibile tagliare l'impasto con estrema facilità e modellare sfere dalla forma perfetta. EasySphere può essere usato da qualsiasi operatore mantenendo lo standard di lavorazione e pezzatura.

**Precisione, facilità, velocità: con EasySphere migliorerai il tuo modo di lavorare.**

**EasySphere is the revolutionary tool that allows you to produce perfectly shaped pastry spheres while cutting labour costs to a minimum.**

The innovative system makes it possible to produce spheres with different type of dough, reducing more than 50% on production time compared to the manual method, with results that are nothing short of excellent. Thanks to the internal roller, it is possible to cut the dough very easily and give it a perfect spherical shape. EasySphere can be used by any operator while maintaining the standard of processing and size.

**Precision, ease, speed: with EasySphere you will improve the way you work.**





Watch  
the VIDEO



How to use  
& recipes

Perché scegliere EasySphere?  
**Con EasySphere avrai:**

- **50%** dei TEMPI di produzione
- + **150%** dell' EFFICIENZA produttiva
- **20%** della MANODOPERA

Why choose EasySphere?  
**EasySphere saves:**

- **50%** of production TIMES
- + **150%** of production EFFICIENCY
- **20%** of LABOUR

## EASYSHERE 20

### 50ES01

Misure ingombro/overall dimensions:  
58,5 x 42 x 36,8 cm  
**per realizzare sfere Ø 20 mm**  
**for making Ø 20 mm balls**

## EASYSHERE 24

### 50ES02

Misure ingombro/overall dimensions:  
58,5 x 42 x 36,8 cm  
**per realizzare sfere Ø 24 mm**  
**for making Ø 24 mm balls**



Accessori inclusi: scovolino per la pulizia del rullo interno, e vassoio estraibile in plexiglass trasparente, per posizionare i filoni di impasto prima della lavorazione in macchina / Accessories included: brush for cleaning the inner roller, and removable transparent plexiglass tray, for positioning the dough loaves before processing in the machine.





## ACCESSORI PER EASYPHERE EASYPHERE ACCESSORIES

**Tagliapasta estensibile in acciaio con 5  
lame lisce/ Extensible steel pasta cutter  
with 5 smooth blades**  
**ROTAPINOX 5 P**

Misura ruote/wheel size: Ø 55 mm  
Distanza ruote/wheel distance: 10/120 mm



**Dime di taglio in plastica trasparente**  
**Transparent plastic grids for cutting**

### **50GD0015**

Griglia speciale per tagli da 1,5 cm.  
Special grid to cut 1,5 cm.  
Ideale per/ideal for EasySphere 20

### **50GD0018**

Griglia speciale per tagli da 1,8 cm.  
Special grid to cut 1,8 cm.  
Ideale per/ideal for EasySphere 24





---

## PALLINATORE MANUALE MANUAL BALL MACHINE

---

Per la produzione manuale di  
"Baci di Dama", praline e palline  
di marzapane.

For the manual production of  
"Lady's Kisses", pralines and  
marzipan balls.



### PALL1

Misure ingombro/overall dimensions:  
31 x 39 x 18 cm  
**per realizzare sfere Ø 16 mm**  
**for making Ø 16 mm balls**

artellato

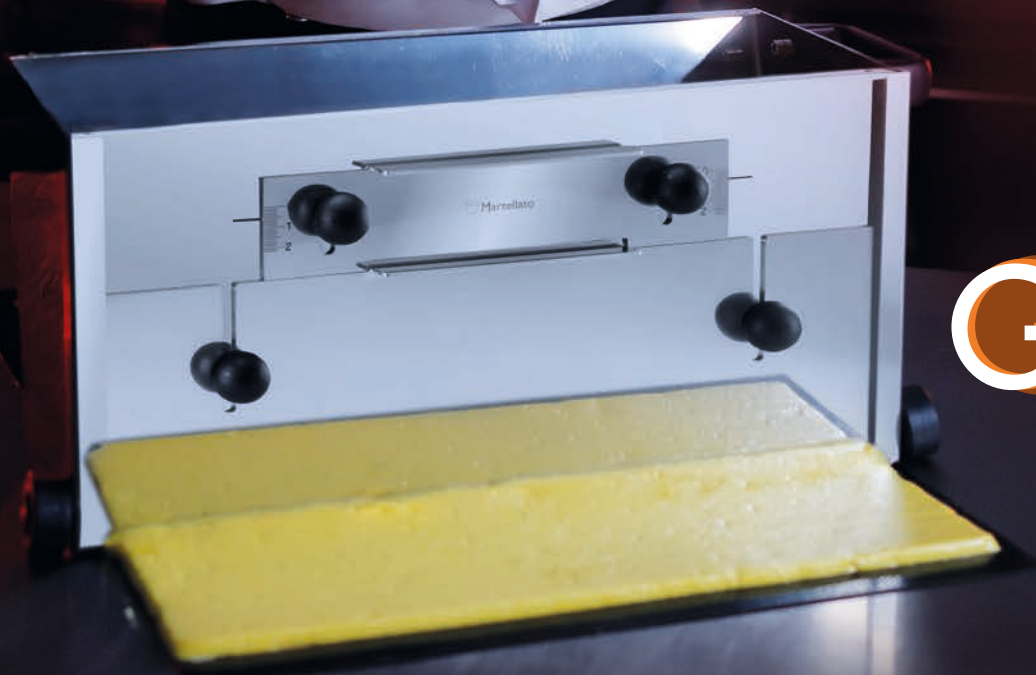

GIUSEPPE  
GAGLIARDI  
MAESTRO  
PASTICCERE

# LEVEL

---

## BISCUIT & MORE

## STRATIFICAZIONE PERFETTA

Level: stendi impasto su ruote maneggevole e pratico che permette di creare rapidamente strati precisi ed uniformi, anche negli spessori più sottili. Facilita e velocizza la stesura uniforme di biscuit, pan di spagna, cioccolato e prodotti simili, scorrendo su diverse superfici, come carta forno o tappeti in silicone. **Level è progettato per razionalizzare la produzione: velocizza i tempi, semplifica i passaggi e riduce i costi.**

## PERFECT LAYERING

Level: handy and practical wheel-mounted dough spreader that allows you to quickly create precise and regular layers, even in the thinnest thicknesses. It facilitates and speeds up the uniform spreading of biscuit, sponge cakes, chocolate and similar products, sliding on different surfaces, such as baking paper and silicone mats. **Level is designed to rationalise production: it speeds up times, simplifies steps and reduces costs.**

*"Level è uno strumento che ho pensato per tutti coloro che come me cercano precisione e funzionalità, per creare prodotti perfetti."*

*"Level is a tool that I have designed for all those who, like me, are looking for precision and functionality to create perfect products."*

## LEVEL

**Stendi impasto in acciaio inox**  
**Stainless steel dough spreader**  
**50LE001**

Misure ingombro/overall  
dimensions: 48 x 20 h 20 cm



## CARATTERISTICHE TECNICHE

**Completamente** in acciaio inox

**Scala graduata** millimetrica

**Manopole** di regolazione

**Ruote direzionali** per scorrimento veloce

**Parete mobile** per regolazione spessore

**Divisori interni** per regolare il flusso

**Kit accessori** per regolazione precisa  
degli spessori sottili

**Capacità max** 12 lt

**Peso:** 4,3 kg

**Misura totale:** 48 x 20 h 20 cm

**Larghezza apertura:** 38 cm

---

## TECHNICAL FEATURES

**Made entirely** of stainless steel

Millimetric **graduated scale**

Adjustment **knobs**

**Directional wheels** for fast sliding

**Movable wall** for thickness adjustment

**Internal dividers** for flow adjustment

**Accessory kit** for precise adjustment of thin  
shims

**Maximum capacity** 12 lt

**Weight:** 4,3 kg

**Total size:** 48 x 20 h 20 cm

**Slot width:** 38 cm

**MADE IN ITALY**

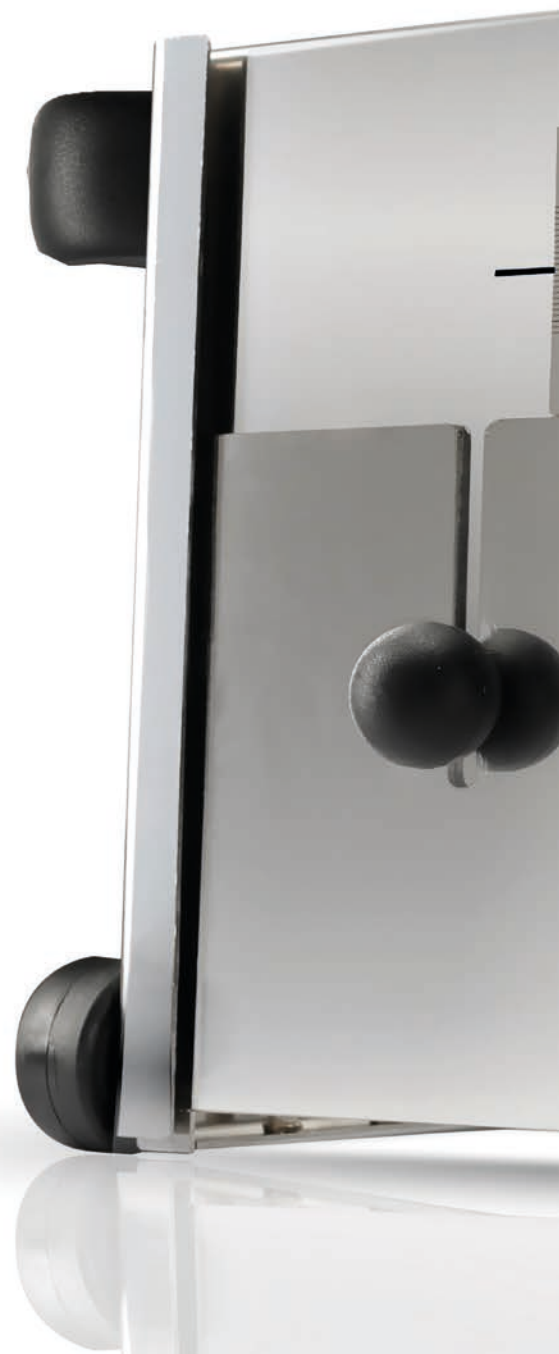



Watch  
the VIDEO

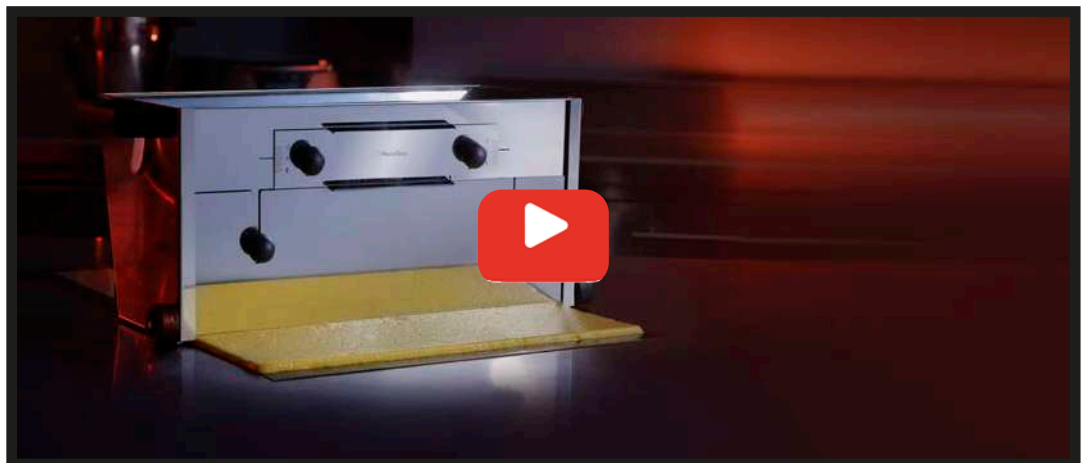

# THERMAL

## WARMING PLATE

**Piastra elettrica riscaldante** con piano in vetro temperato idoneo al contatto alimentare, ideale nella lavorazione del cioccolato. E' inoltre perfetta per riscaldare e mantenere caldi i cibi, risultando la soluzione **adatta ai buffet di catering, alberghi e ristoranti**.

L'apparecchiatura è composta da una robusta struttura metallo, con fondo riscaldante, il piano in vetro temperato, il termostato per la regolazione della temperatura e piedini antiscivolo per garantire **stabilità e sicurezza** anche durante il funzionamento.

Facile da trasportare, grazie al design compatto ed al peso ridotto, e facile da pulire con un panno morbido e umido.

### CARATTERISTICHE PRINCIPALI:

Struttura in metallo

Superficie in vetro temperato

Range temperatura: 30°C - 85°C

Spia luminosa di funzionamento

Potenza 260 W

Peso: 2.5 Kg

**Electric warming plate** with a tempered glass top suitable for food contact, ideal for working with chocolate. Perfect for heating and keeping food warm, it also represents the **solution for catering buffets, hotels and restaurants**.

The equipment has a strong metal structure provided with a heating base, a tempered glass top, a thermostat for temperature regulation and non-slip pads to guarantee **stability and safety**, even during operation. Thanks to the compact design and low weight, it is easy to carry and clean with a soft damp cloth.

### MAIN FEATURES:

Metal construction

Tempered Glass surface

Temperature range: 30°C - 85°C

Operating indicator light

Power 260 W

Weight: 2.5 Kg



Watch  
the VIDEO



## THERMAL

**Piastra riscaldante**  
**Warming Plate**  
**50PR02**

Misure ingombro/overall dimensions:  
64 x 45,5 x h 7,5 cm



Su richiesta disponibili con cablaggio GB - USA - AUSTRALIA/ On request available with GB - USA - AUSTRALIA wiring

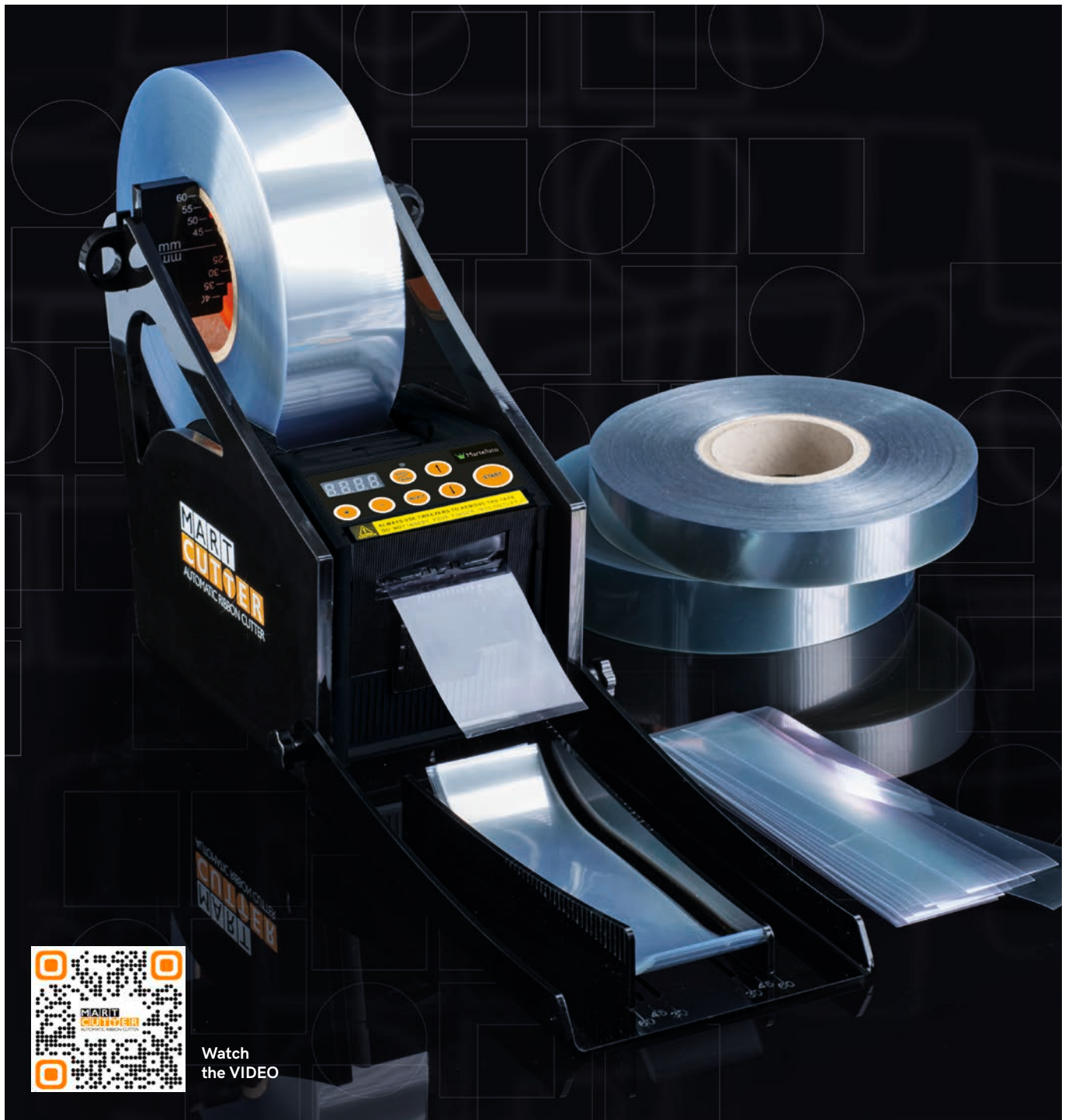

Watch  
the VIDEO

## MART CUTTER

Taglianastri automatico  
Automatic ribbon cutter  
50MC001

Ingombro minimo/min. size: 25 x 17,5 h 29 cm  
Ingombro max/max size: 48,3 x 17,5 h 29 cm



# MART CUTTER

AUTOMATIC RIBBON CUTTER

## TAGLIATO PER LA PASTICCERIA CUT OUT FOR PASTRY

**Mart Cutter** è il **taglianastrì elettrico** ideale per **tagliare automaticamente le bobine di acetato della lunghezza desiderata, nella quantità necessaria**. Lo strumento consente di ottimizzare e gestire con maggiore semplicità lo stock delle diverse misure, producendo la quantità necessaria di ciascuna lunghezza, evitando errori di taglio e perdite di tempo.

**La confezione include** taglianastrì elettrico, supporto per bobine, vassoio in plex per contenere le strisce di acetato e copertura di cotone per riporre il taglianastrì dopo l'uso.

**Mart Cutter** is the ideal **electric ribbon cutter** for **automatically cutting rolls of acetate to the desired length, in the necessary quantity**. The tool makes it easier to optimise and manage the stock of different sizes, producing the necessary quantity of each length, avoiding cutting errors and waste of time.

**Package includes** electric ribbon cutter, reel stand, plex tray to hold acetate strips and cotton cover to store the ribbon cutter after use.



Grazie al display digitale **puoi impostare** sia la **lunghezza di taglio**, scegliendo tra i programmi preimpostati o inserendola manualmente, sia il **numero di strisce** desiderate.

Thanks to digital display you can set both the **cutting length**, choosing from preset programs or entering it manually, and the **desired number of stripes**.

**CARATTERISTICHE PRINCIPALI:**

Larghezza bobine: fino a 60 mm

Ø bobine: max 210 mm

Spessore acetato: 80/150 my

Misure di taglio: da 5 a 999 mm

Lunghezze preimpostabili: fino a 6

Peso 2,9 kg

Potenza 25 W

Tensione elettrica 100V, 120V, 220-240V  
(altri cavi di alimentazione su richiesta)

**MAIN FEATURES:**

Rolls width: up to 60 mm

rolls Ø: max 210 mm

Acetate thickness: 80/150 my

Cutnig sizes: da 5 a 999 mm

Pre-settable lenghts: up to 6

Weight 2,9 kg

Power 25 W

Electric voltage 100V, 120V, 220-240V  
(other power cable on request)



Supporto bobine con sedi per accogliere bobine di diverse larghezze mantenendo la centratura di taglio.

Roll support with slots to accommodate different heights while maintaining cutting centring.



Display digitale a LED per visualizzare le impostazioni scelte e l'avanzamento dello stato del lavoro.

Digital LED display to show selected settings and work status progress.

Vassoio per la raccolta delle strisce tagliate. Dopo l'uso può comodamente essere richiuso per ridurre l'ingombro e proteggere la macchina.

Tray for collecting cut strips. It can be easily folded away after use to reduce clutter and protect the machine.

# ACETATI - ACETATE

Extra trasparenti, super resistenti, prodotti con materiale di alta qualità. Facili da usare per rivestire stampi e per realizzare e sformare monoporzioni e mignon. Antiaderenti per uso alimentare. Adatti al raffreddamento in abbattitore, congelatore e frigo, ma non adatti alla cottura.

Extra-clear, super-strong, made of high-quality material. Easy to use for coating moulds and for making and un moulding monoportions and mignons. Non-stick for food use. Suitable for cooling in blast chillers, freezers and fridges, but not suitable for baking.

## NASTRI - RIBBONS



<i>h (mm)</i>	<i>Codice - Code</i>	<i>h (mm)</i>	<i>Codice - Code</i>
h 25	NSA H 25	h 45	NSA H 45
h 30	NSA H 30	h 50	NSA H 50
h 35	NSA H 35	h 55	NSA H 55
h 40	NSA H 40	<b>h 60</b>	NSA H 60

### Specifiche / features

spessore / thickness  
80 my

lunghezza  
length 305 mt



anima / core  
Ø 70 mm

misura esterna  
external size  
Ø 210 mm

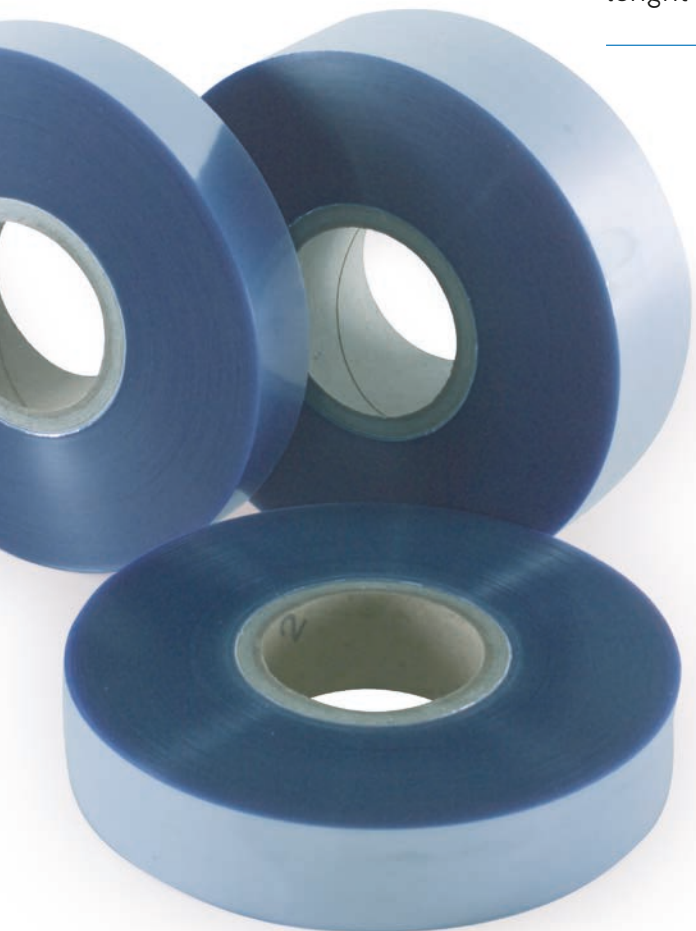

Il materiale multistrato con il quale sono realizzati i nostri nastri proviene parzialmente da plastica riciclata. La loro speciale composizione li rendono idonei al contatto alimentare e rispettosi dell'ambiente.

The multi-layer material with which our ribbons are made comes partly from recycled plastic. Their special composition makes them suitable for food contact and environment-friendly.



Tutti i rotoli sono adatti alla taglianastri  
All ribbons are suitable for ribbon cutter  
**50MC001**

**MART  
CUTTER**  
AUTOMATIC RIBBON CUTTER



# GUITAR

## CUTTER *by* MARTELLATO

**Versatile, funzionale e resistente:** le caratteristiche della nuova chitarra in alluminio la rendono il tuo partner nella produzione quotidiana.

Uno strumento che ti permetterà di lavorare in modo preciso semplificando i passaggi ed **umentando la produttività**. Sarà veloce e facile tagliare cremini, ganache, pasta frolla e sfoglia, tutte le masse morbide, le materie prime ed i prodotti finiti. La struttura é progettata per conferire maggior stabilità e forza nel taglio, ridurre lo sforzo, ottimizzare la produzione, riducendo sprechi, elevando gli standard e l'efficienza.

**Versatile, functional and durable:** thanks to its features, the new aluminum guitar is your essential partner in daily production.

A tool that will allow you to work precisely, simplifying steps and **increasing productivity**. It will be quick and easy to cut creams, ganaches, shortcrust and puff pastry, all soft masses, raw materials and finished products.

The structure is designed to give greater stability and strength in the cutting process, reducing effort and waste, optimizing production, raising standards and efficiency.

**MADE IN ITALY**



### CARATTERISTICHE TECNICHE:

Misura telaio/frames size: 62,2 x 44,2 cm

Misura base/base size: 60 x 40 h 10 cm

Piano di taglio/cutting surface: 38 x 40 mm

Misura totale/total size: 63,6 x 44,2 h 10,9 cm

Peso base/ base weight 5,5 kg

Peso telaio/ frame weight 5,5 kg

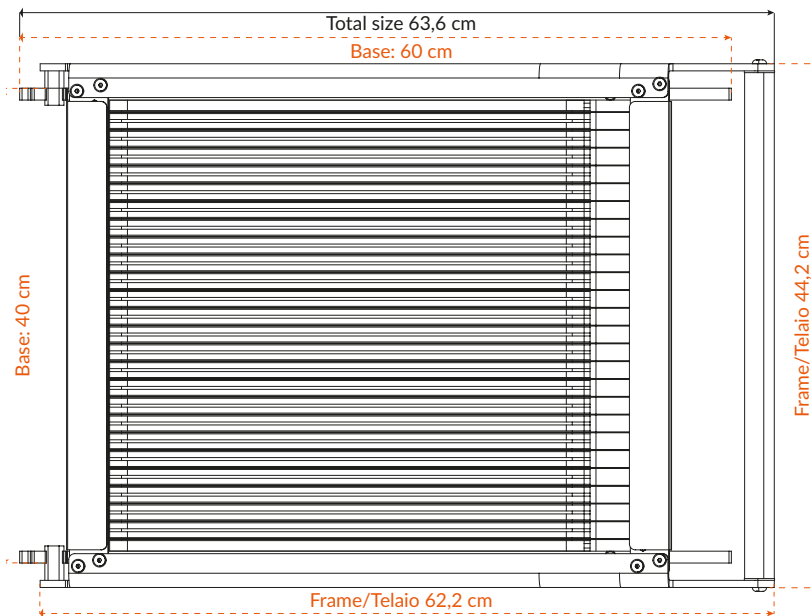
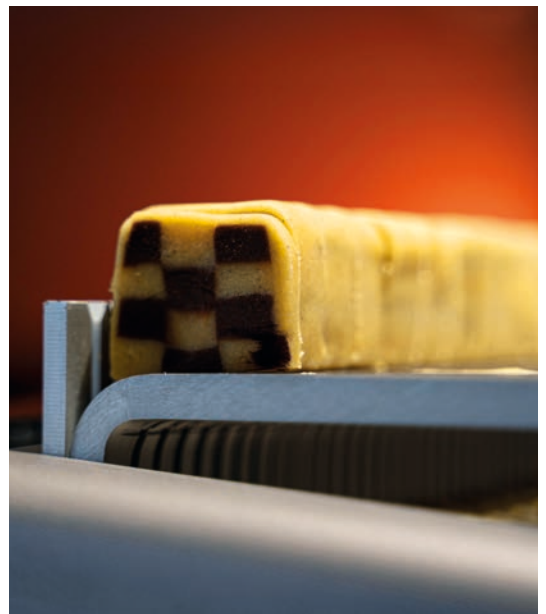

Watch  
the VIDEO



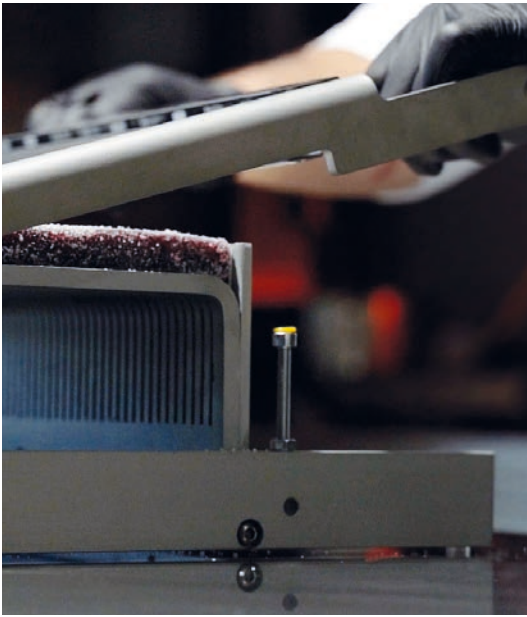

## BASE

La base, realizzata completamente in alluminio, ha l'**angolo di taglio più ampio per dare maggiore forza meccanica** e ridurre lo sforzo del professionista. E' inoltre più ampia ed allungata per una **maggiore stabilità durante il taglio**. La sua struttura garantisce maggiore maneggevolezza e facilità di pulizia.

The base, made entirely of aluminum, has a **wider cutting angle to give greater mechanical strength** and reduce the professional's effort. It is also wider and longer to give **more stability during cutting**. Its structure ensures greater handling and ease of cleaning.

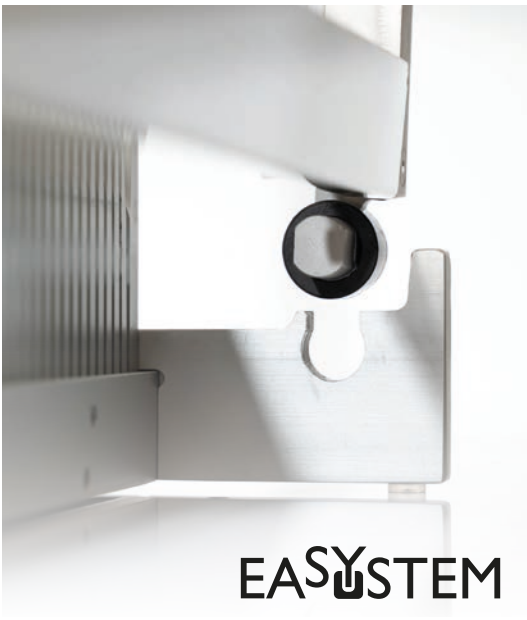

## TELAIO /FRAME

**Telai in acciaio**, con manico ergonomico, facilmente intercambiabili grazie a **Easy System**, l'esclusivo sistema di incastro che ne facilita l'inserimento. Sono **disponibili in diverse misure di taglio per consentire varie combinazioni** e creare mignon, monoporzioni, cremini, praline e altro.

Sono inclusi vassoio in acciaio e la raplette in plastica per facilitare lo spostamento dei prodotti.

**Steel frames**, with ergonomic handle, are easily interchangeable thanks to the **Easy System**, the exclusive interlocking system that facilitates insertion. They are **available in different cut sizes to allow various combinations** and create mignons, single portions, cremini, pralines and more. The steel tray and the plastic raplette are included to facilitate the movement of the products.

EASY SYSTEM



# Every Day

# with you

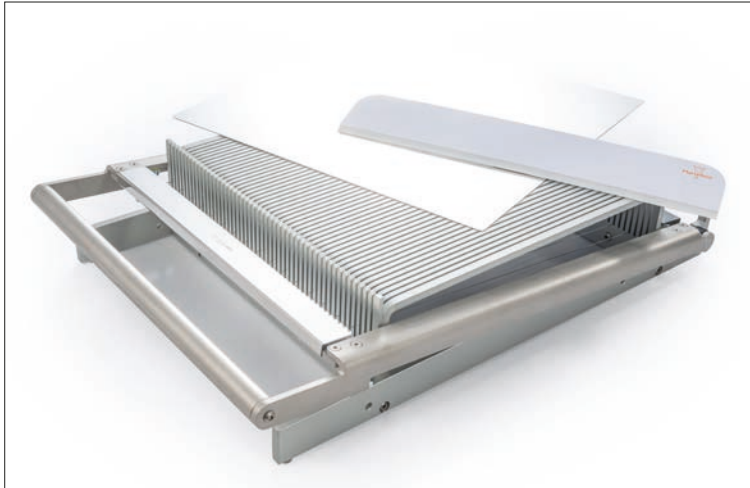

## GUITAR CUTTER

**FULL SET**  
**50CS200**

- 1 Base 60 x 40 h 10 cm
- 3 telai/frames, misure di taglio/cutting distances: 22,5 - 30 - 45 mm
- 1 Raplette
- 1 Piano acciaio inox/Stainless steel plate
- 1 Kit assistenza/Service kit
- Misura totale/Total size: 636 x 441 h 109 mm



## GUITAR CUTTER

**BASE**  
**50CSBA**

Piano di taglio/Cutting surface: 38 x 40 cm  
Misura totale/Total size: 60 x 40 h 10 cm



## GUITAR CUTTER

**TELAI/FRAMES**

**50CSTE15**

Misura taglio/Cutting size: 15 mm

**50CSTE22**

Misura taglio/Cutting size: 22,5 mm

**50CSTE30**

Misura taglio/Cutting size: 30 mm

**50CSTE37**

Misura taglio/Cutting size: 37,5 mm

**50CSTE45**

Misura taglio/Cutting size: 45 mm

# CHITARRE - GUITARS

## EASY SYSTEM

Il sistema ad incastro facilita l'inserimento ed il cambio dei telai, riducendo i tempi di montaggio, smontaggio e manutenzione.  
The interlocking system makes it easier to insert and change frames, reducing assembly, disassembly and maintenance time.

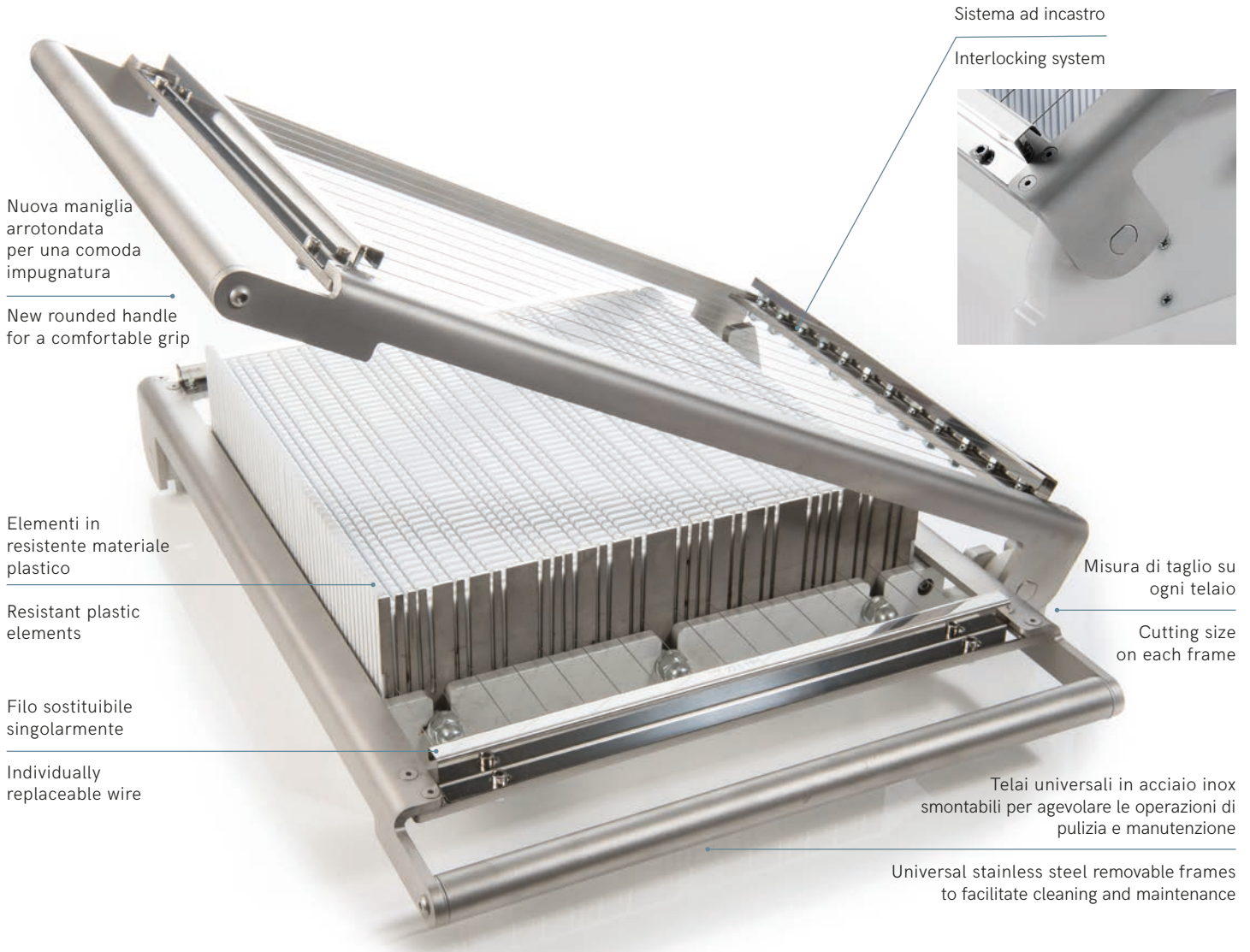

La chitarra è lo strumento ideale per tagliare in modo preciso **cremini, ganache, gelatine, mignon e masse morbide**. La base di taglio è realizzata in resistente materiale plastico, i telai sono in acciaio inox e i fili intercambiabili singolarmente.

**La chitarra è composta da una solida base e da telai di diverse misure, fornibili separatamente** in base alle esigenze del singolo operatore, oltre ad essere predisposta per il taglio e il calibro di grandi quantità di prodotti in modo preciso e privo di imperfezioni. Nella confezione delle basi sono presenti: 1 piatto in acciaio inox - 1 racla PST - 3 fili di ricambio - 2 chiavi per il fissaggio fili.

The guitar is the ideal tool for cutting **cremini, ganache, jellies, mignons and soft masses** precisely. The cutting base is made of strong plastic material, the frames are made of stainless steel and the wires are individually interchangeable.

**The guitar consists of a solid base and frames of different sizes, which can be supplied separately** according to the needs of the individual operator, as well as being predisposed for cutting and calibrating large quantities of products precisely and without imperfections. In the packaging of the bases there are: 1 stainless steel plate - 1 plastic spatula - 3 spare wires - 2 keys for fixing wires.

## DOUBLE

La chitarra doppia permette di tagliare rapidamente il prodotto in un unico passaggio. Ideale per produrre perfetti quadrati e rettangoli di diverse dimensioni.

The double guitar allows you to quickly cut the product in a single operation. Ideal for producing perfect squares and rectangles of different sizes.

### 50-CD100N

BASE CON PIANO DI TAGLIO  
BASE WITH CUTTING SURFACE

## 36X35CM

TELAI NON INCLUSI.  
FRAMES NOT INCLUDED.



Telaio base in alluminio  
Aluminum base frame

## SINGLE

### 50-CS100

BASE CON PIANO DI TAGLIO  
BASE WITH CUTTING SURFACE

## 36X42CM

TELAI NON INCLUSI.  
FRAMES NOT INCLUDED.



Base in polietilene  
Polyethylene base

## TELAI - FRAMES

Misura-Size: 615x427 mm

Maniglia arrotondata per una comoda impugnatura  
Rounded handle for a comfortable grip

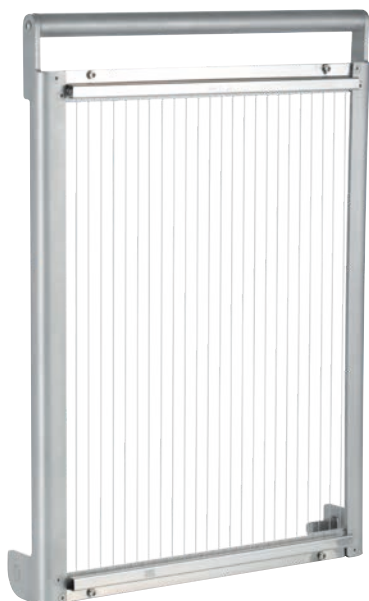

TELAIO PER TAGLIO FRONTALE  
FRAME FOR FRONTAL CUTTING

15 mm  
50-C015

TELAI PER TAGLIO FRONTALE E LATERALE  
FRAMES FOR FRONTAL AND SIDE CUTTING

22 MM                      30 MM                      45 MM  
50-C022                      50-C030                      50-C045

### Parti ricambio - Spare parts

Piatto Inox  
Steel Sheet  
CHITRIC 6/D

Spatola Plastica  
Plastic spatula  
50SPB43  
430 h80 mm

Chiavi fissaggio  
Special Spanner  
CHITRIC 8  
2 pcs

Filo Inox  
Inox wire  
CHITRIC 9  
1 pc

Viti e Dadi  
Bolts and Nuts  
CHITRIC 10  
2+2 pcs

# MINI CHITARRE - MINI GUITARS

## EASY SYSTEM

Il sistema ad incastro facilita l'inserimento ed il cambio dei telai, riducendo i tempi di montaggio, smontaggio e manutenzione.  
The interlocking system makes it easier to insert and change frames, reducing assembly, disassembly and maintenance time.

Filo sostituibile singolarmente

Individually replaceable wire

Elementi in resistente materiale plastico

Resistant plastic elements

Base in polietilene leggera e maneggevole

Base in light and handy polyethylene

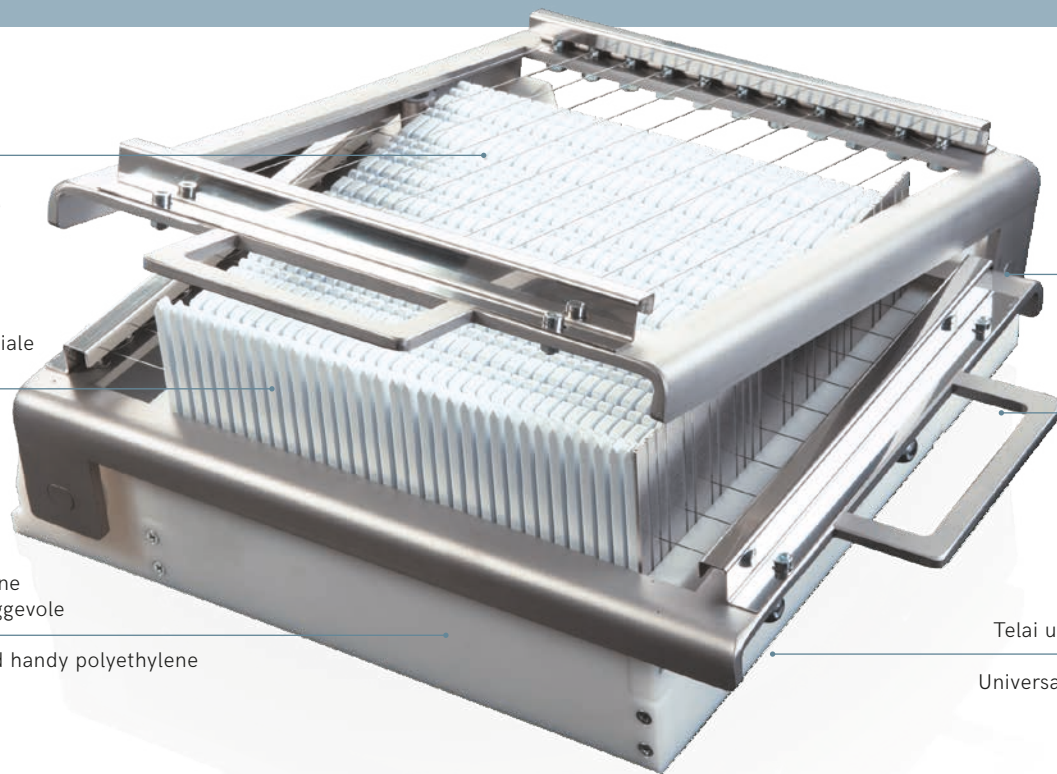

Sistema ad incastro

Interlocking system

Misura di taglio su ogni telaio

Cutting size on each frame

Telai universali in acciaio inox

Universal stainless steel frames

**La MiniChitarra**, ideale per ristoranti, gelaterie e cioccolaterie, è adatta a piccole produzioni di prodotti dolciari. Grazie alle dimensioni contenute può essere facilmente riposta anche in piccoli spazi e utilizzata all'occorrenza. Inclusi nella confezione: 1 piatto inox - 1 racla PST - 3 fili di ricambio - 2 chiavi per il fissaggio fili.

**The Mini Guitar**, ideal for restaurants, ice-cream and chocolate shops, is suitable for small productions of confectionery products. Thanks to its small size it can be easily stored even in small spaces and used when necessary. Included in the package: 1 stainless steel plate - 1 plastic spatula - 3 spare wires - 2 keys for wire fixing.

## SINGLE

BASE CON PIANO DI TAGLIO  
BASE WITH CUTTING SURFACE

### 25X28CM

1 TELAIO INCLUSO.  
1 FRAME INCLUDED.

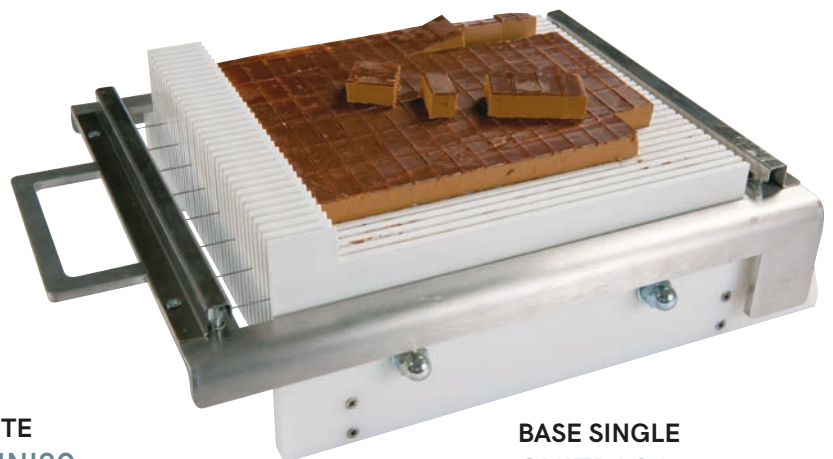

**COMPLETE CHITMINI15**  
con 1 telaio 15 mm  
with 1 frame 15 mm

**COMPLETE CHITMINI**  
con 1 telaio 22 mm  
with 1 frame 22 mm

**COMPLETE CHITMINI30**  
con 1 telaio 30 mm  
with 1 frame 30 mm

**BASE SINGLE CHITBA24**  
Base - senza telai  
Base - without frames

## DOUBLE



La chitarra doppia permette di tagliare rapidamente il prodotto in un unico passaggio. Ideale per produrre perfetti quadrati e rettangoli di dimensioni differenti. Telai smontabili per agevolare le operazioni di pulizia e manutenzione.

The double guitar allows you to quickly cut the product in one step. Ideal for producing perfect squares and rectangles of different sizes. Removable frames to facilitate cleaning and maintenance.

BASE CON PIANO DI TAGLIO  
BASE WITH CUTTING SURFACE

### 24X25CM

2 TELAI INCLUSI  
2 FRAMES INCLUDED

**COMPLETE**  
**CHITMINID22**  
con 2 telai da 22 mm  
with 2 frames 22 mm

**COMPLETE**  
**CHITMINID30**  
con 2 telai da 30 mm  
with 2 frames 30 mm



**BASE DOUBLE**  
**CHITBAD24**  
Base - senza telai  
Base - without frames

## TELAI - FRAMES

Misura-Size: 443x314 mm



**TELAIO PER TAGLIO FRONTALE**  
**FRAME FOR FRONTAL CUTTING**

**15 mm**  
**CHIT15**

**TELAIO PER TAGLIO FRONTALE E LATERALE**  
**FRAME FOR FRONTAL AND SIDE CUTTING**

**22,5 mm**  
**CHIT22**  
intercambiabile  
interchangeable

**30 mm**  
**CHIT30**  
intercambiabile  
interchangeable

## Parti ricambio - Spare parts

**Piatto Inox**  
**St. steel Sheet**  
**CHITP**

**Spatola Plastica**  
**Plastic spatula**  
**50SPB30**  
300 h80 mm

**Chiavi Fissaggio**  
**Special Spanner**  
**CHITRIC 8**  
2 pcs

**Filo Inox**  
**Inox wire**  
**CHITRIC 9**  
1 pc

**Viti e Dadi**  
**Bolts and Nuts**  
**CHITRIC 10**  
2+2 pcs

# CHITARRE A SPINTA DRIVING-FORCE GUITARS

Ideale per tagliare **cremini e ganache con frutta secca o prodotti duri e piccola pasticceria anche a bassa temperatura**. L'avanzamento del piano di lavoro avviene manualmente, attraverso un volantino azionato dall'operatore, che può controllarne la velocità. Il filo corto garantisce una maggiore resistenza meccanica e consente quindi di tagliare in porzioni precise anche gli impasti più duri o congelati. Facile da pulire, questo strumento non richiede alcuna manutenzione.

Ideal for cutting **cremini and ganache with dried fruit or hard products and small pastries even at low temperature**. The advancement of the work table is done manually, through a handwheel operated by the user, who can control its speed. The short wire guarantees greater mechanical resistance and therefore allows even the hardest or frozen dough to be cut into precise portions. Easy to clean, this tool does not require any maintenance.

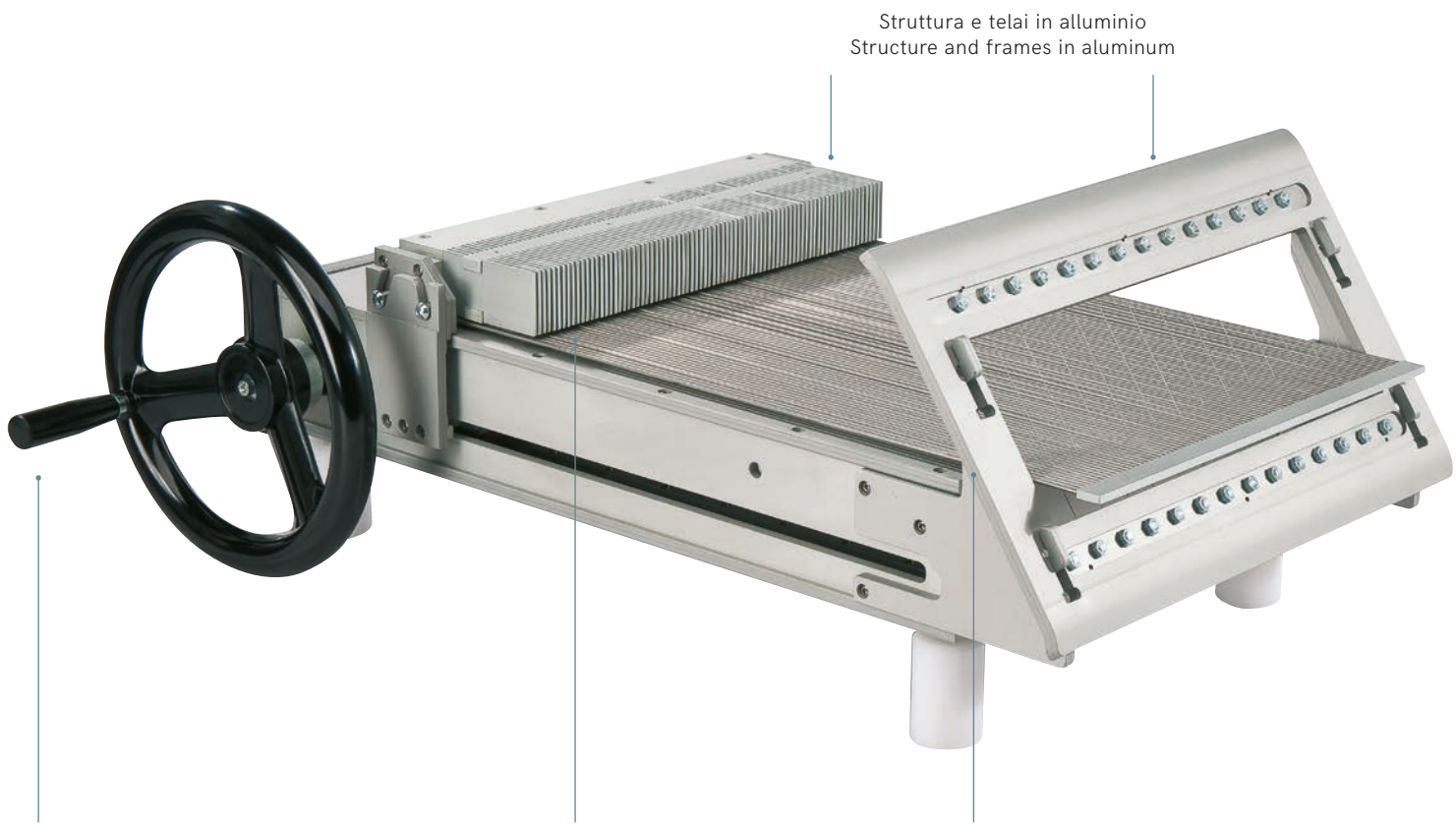

Struttura e telai in alluminio  
Structure and frames in aluminum

Manopola di avanzamento grande per permettere un taglio più preciso e delicato

Large hand wheel to allow a more precise and delicate cut

Base di avanzamento asportabile per una migliore pulizia

Removable base for better cleaning

Inserimento dei telai ad incastro  
Frame insertion by interlocking

## Parti ricambio - Spare parts

**Piatto Inox  
Steel Sheet**  
**CSM0602**  
Ideal for:  
CSM060 BIG

**Spatola  
Spatula**  
**CSMSPB60**  
Ideal for:  
CSM060 BIG

**Piatto Inox  
Steel Sheet**  
**CSM0402**  
Ideal for:  
CSM040 SMALL

**Spatola  
Spatula**  
**CSMSPB40**  
Ideal for:  
CSM040 SMALL

**Chiavi di fissaggio  
Spanners**  
**CHITRIC 8**

**Filo Inox  
Inox wire**  
**CHITRIC 9**

Inclusi nella confezione delle basi: 1 piatto inox - 1 racla PST - 2 chiavi per il fissaggio fili.  
Included in the package: 1 stainless steel plate - 1 plastic spatula - 2 keys for wire fixing.



### CSM060

PIANO DI TAGLIO  
CUTTING SURFACE

## 60X60CM

TELAI NON INCLUSI.  
FRAMES NOT INCLUDED.

Misura chitarra chiusa  
Closed guitar size:  
**73x103 h30 cm**  
Misura apertura massima  
Maximum open size:  
**73x167 cm**

## 60X60CM

### TELAI - FRAMES

10 MM - CSM06001  
15 MM - CSM06002  
20 MM - CSM06003  
25 MM - CSM06004  
30 MM - CSM06005  
35 MM - CSM06006  
40 MM - CSM06007  
50 MM - CSM06008  
60 MM - CSM06009

### CSM040

PIANO DI TAGLIO  
CUTTING SURFACE

## 40X40CM

TELAI NON INCLUSI.  
FRAMES NOT INCLUDED.

Misura chitarra chiusa  
Closed guitar size:  
**53x83 h30 cm**  
Misura apertura massima  
Maximum open size:  
**53x126 cm**

## 40X40CM

### TELAI - FRAMES

10 MM - CSM04001  
15 MM - CSM04002  
20 MM - CSM04003  
25 MM - CSM04004  
30 MM - CSM04005  
35 MM - CSM04006  
40 MM - CSM04007  
50 MM - CSM04008  
60 MM - CSM04009



# PERFECT LAYERS

Stratificazione perfetta! Telai precisi e facili da usare per creare cremini, ganache e gelatine di frutta multi-strato con pesi ed altezze sempre costanti.

Perfect layering! Precise and easy to use frames to create cremini, ganaches and multi-layer fruit jellies with constant weights and heights.

## 50TLSPECIAL

MISURA INTERNA  
INTERNAL SIZE

### 36X36 CM

2+2 QUADRI INCLUSI.\*  
2+2 FRAMES INCLUDED.\*

\* h 3 mm

50TLS03

\* h 5 mm

50TLS05

\* Plastic spatula

50SPB43

430 h80 mm

fogli acetato

NSA39X39MO

390x390 mm

pack 100 pcs



## 50TLMINI

MISURA INTERNA  
INTERNAL SIZE

### 24X24 CM

2+2 QUADRI INCLUSI.\*  
2+2 FRAMES INCLUDED.\*

\* h 3 mm

50TLM03

\* h 5 mm

50TLM05

\* Plastic spatula

50SPB30

300 h80 mm

fogli acetato

NSA27X27MO

270x270 mm

pack 100 pcs



# SINGLE LAYERS

Telai in acciaio inox per creare precise stratificazioni in cioccolato, biscuit e altri impasti in modo semplice e veloce.  
Stainless steels frames to produce perfect layers in chocolate, biscuit and other doughs in easy and fast way.

**FIXED FRAMES**  
MISURA INTERNA  
INTERNAL SIZE  
**36X36CM**

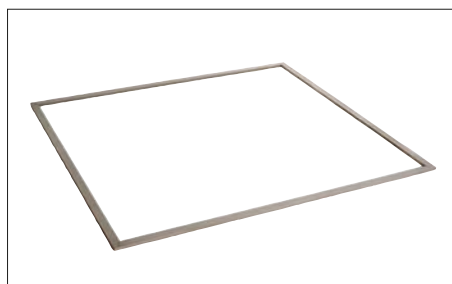

**50QG03**  
h 3 mm  
Misura esterna/External Size: 38x38 cm

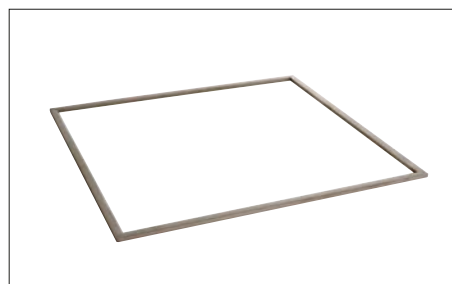

**50QG05**  
h 5 mm  
Misura esterna/External Size: 38x38 cm

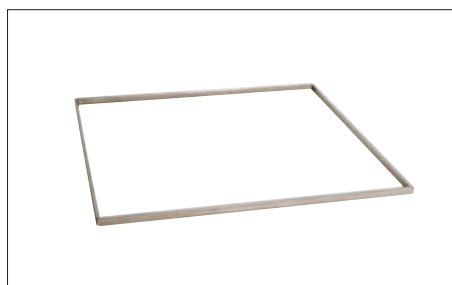

**50QG10**  
h 10 mm  
Misura esterna/External Size: 37x37 cm

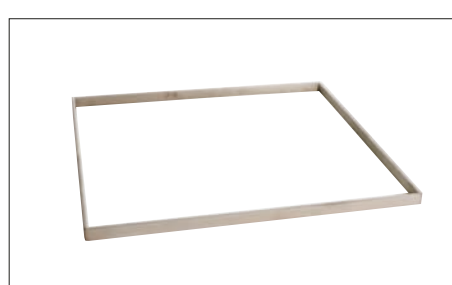

**50QG15**  
h 15 mm  
Misura esterna/External Size: 37x37 cm

**PLASTIC FRAMES**  
MISURA INTERNA  
INTERNAL SIZE  
**37X57CM**  
Misura esterna  
External Size: 47x67 cm

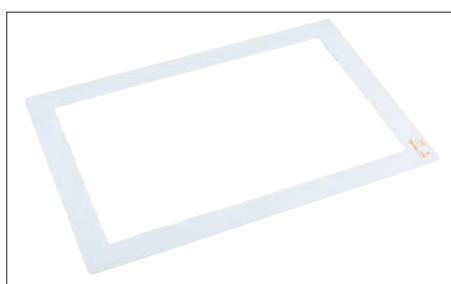

**TL 03**    **TL 04**    **TL 05**  
h 3 mm    h 4 mm    h 5 mm

**CHARLOTTE FRAME**  
MISURA INTERNA  
INTERNAL SIZE  
**38X58CM**  
Misura esterna  
External Size: 39x59 cm

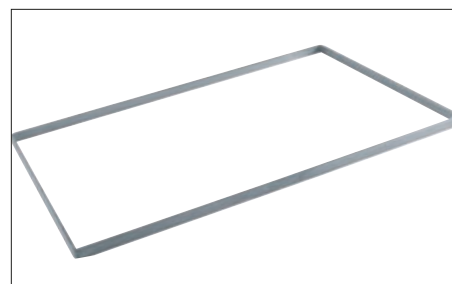

**TL 15**  
h 15 mm

# SPINNER

*E-Turning Cake*

L'indispensabile giratorta elettrico per il tuo laboratorio  
*Electric Cake Turntable: an essential tool for your laboratory*



Composto da un **corpo stabile** con trascinatore circolare sul quale ruota un **piano perfettamente planare** in plexiglass, con **scala graduata** in cm ed inch, consente il corretto e costante posizionamento del prodotto e la misurazione del decoro.

The cake turntable is composed by a **stable base** with circular guide and **planar Plexiglas plate**, with **graduated scale** for the correct and constant positioning of the product and the measurement of the decoration.

Con il regolatore puoi **variare la velocità** e il **senso di rotazione**. I **led direzionali** indicano il senso di rotazione ed in base all'intensità la velocità. Il pratico tappetino in silicone antiscivolo garantirà maggiore stabilità durante la lavorazione.

The regulator allow to **vary speed** and **direction of rotation**. **LEDs indicate direction** and speed of rotation. The practical non-slip silicone mat will ensure greater stability during processing.

Il giratorta elettrico: compatto, pratico e leggero, che semplifica e aiuta il tuo lavoro.

The electric turning cake: compact, practical and light, that simplifies and helps your work.

## SPINNER

Misure / Size: 27 x 26 h 12 cm

Peso / Weight: 1,6 Kg

MADE IN ITALY



Watch  
the VIDEO



Regolatore di velocità

Speed regulator

Piatto con scala graduata  
da 60 a 220 mm

Graduated plate between  
2,36 and 8,66 inch

Anello trascinatore circolare

Roller ring support

Luminosità LED proporzionale  
alla velocità

LED brightness proportional  
to speed

Piatto in plexiglass  
e tappeto in silicone

Plexiglass plate and silicone mat

Rotazione oraria  
ed antioraria

Clockwise  
and anti-clockwise rotation



# GIRATORTA - CAKE TURNTABLE



**PROFESSIONAL**  
Giratorta in lega di alluminio  
anodizzato/Anodised aluminium  
alloy cake turntable

**GIRA6** - Ø 30 H 13 CM

Resistente alle abrasioni, agli acidi e facile  
da pulire/Resistant to abrasion, acids and  
easy to clean



**BASIC**  
Giratorta in lega di alluminio  
Aluminium alloy cake turntable

**GIRA5** - Ø 29 H 13 CM

Resistente e planare/Resistant and flat



Giratorta in plastica/Plastic cake  
turntable

**GIRA** - Ø 32 H 10 CM



Giratorta in plastica/Plastic cake  
turntable

**GIRA7** - Ø 30,4 H 3,2 CM



**INCLINABILE-TILTING**  
Giratorta in plastica/Plastic cake  
turntable

**40-W125** - Ø 23 H14 CM

Inclinabile fino a 20°, con tappeto  
antiscivolo per mantenere stabile il dolce/  
Tilting up to 20°, with non-slip mat to  
keep cake stable



**PALA PER DOLCI - CAKE  
LIFTER**  
Acciaio inox/stainless steel

**TS1** - Ø 28 CM

Rende facile lo spostamento di  
torte, crostate, pane e articoli  
da forno/For easy handling and  
moving of a whole cakes, tarts,  
pastry, bread and bakery items.



# STENDI PASTA - ROLLING MACHINE

La stendi pasta permette una grande economia di tempo e soprattutto non necessita di personale specializzato per operare. È stata ideata e realizzata per risolvere i problemi di formatura dei dischi per la preparazione di pizze, pane, focacce, tortine, ecc. La macchina lavora a freddo e non altera le caratteristiche della pasta. La stendi pasta è di semplice utilizzo e offre una qualità costruttiva di altissimo livello. Selezionare gli spessori per l'impasto finale è un'operazione rapida ed intuitiva.

The rolling machine allows a great economy of time and above all it does not require specialised personnel to operate. It is designed and manufactured to solve the problems of forming discs for the preparation of pizzas, bread, focaccia, cakes, etc.. The machine works cold and does not alter the characteristics of the dough. The rolling machine is easy to use and offers the highest level of construction quality. Selecting the thicknesses for the final dough is a quick and intuitive operation.



## 31 CM

LUNGHEZZA RULLO  
ROLLER LENGTH

**40-W200**

Ingombro totale - Total overall size:  
45x35,5 - h37,5cm

## 50 CM

LUNGHEZZA RULLO  
ROLLER LENGTH

**40-W20045**

Ingombro totale - Total overall size:  
65x35,5 - h37,5cm

**Scocca di protezione:** protezione dei rulli in plexiglass trasparente per la massima sicurezza, senza alterare la visibilità.

**Protective Shell:** transparent plexiglass roller protection for maximum safety, without altering visibility.

**Monorullo in teflon**  
**Teflon single roller**

**Manopola per la regolazione del spessore**  
**Thickness adjuster knob**

**1 • 2 • 3 • 4 mm**

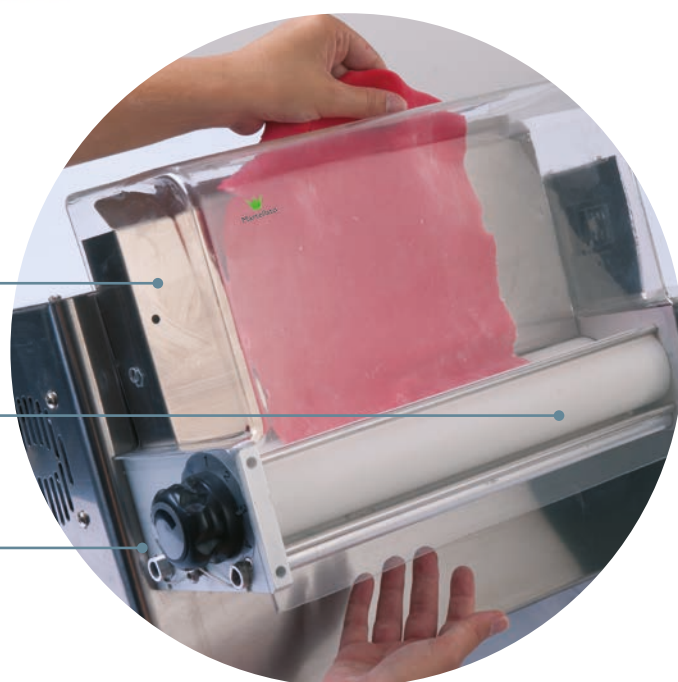

Potenza motore monofase: KW 0,25 - Alimentazione: 230 1ph 50Hz  
Single-phase motor power: KW 0,25 - Power supply: 230 1ph 50Hz

# EASY COVERS

**IL SISTEMA PIÙ COMPLETO PER CONSERVARE I TUOI PRODOTTI**  
*THE MOST COMPLETE SYSTEM TO PROTECT YOUR PRODUCTS*

MADE IN ITALY



## **LEGGEREZZA**

Realizzati in materiale plastico di alta qualità, sono ultra leggeri e facili da trasportare

## **LIGHTNESS**

*Made of high quality plastic material, they are ultra-light and easy to transport*

## **RESISTENZA**

Infrangibili, indeformabili e con elevata elasticità, resistono agli urti anche a bassissime temperature

## **RESISTANCE**

*Unbreakable, non-deformable and with high elasticity, they resist to impact even at very low temperatures*



## **PROTEZIONE**

La superficie trasparente ed opalescente protegge dalla luce e consente di vedere il prodotto all'interno

## **PROTECTION**

*The opalescent and transparent surface protects from light and allows you to see the product inside*





## COPERCHI E VASSOI IN DIVERSE ALTEZZE E MISURE PER STOCCARE E PROTEGGERE LE VOSTRE CREAZIONI

COVERS AND TRAYS OF DIFFERENT HEIGHTS AND SIZES TO STORE AND PROTECT YOUR CREATIONS

### COPERCHI E VASSOI LIDS AND TRAYS

Size cm	Code
59,5x39,5 h 4,2	VC60X404
59,5x39,5 h 6,2	VC60X40
59,5x39,5 h 8,2	VC60X408
30x40 h 6,2	VC30X40

### COPERCHI LIDS

Size cm	Code
59x39 h 4	COVER 3H4
59x39 h 4,5	COVER3H45
59x39 h 4,8	COVER3H48
59x39 h 6	COVER 3
59x39 h 8	COVER 8
30x40 h 6	COVER 4



### VASSOI TRAYS

Size cm	Code
59,8x39,6 h 2	VASSOIOCMI
39,5x29,8 h 2	VASSOIOBMI

### ALTRE MISURE OTHER SIZE

Size cm	Code
59x39,6 h 2,5	VASSOIOCMI
39,5x17,3 h 2	VASSOIOAMO
39,5x20 h 2	VASSOIOAMI
39,5x25,8 h 2	VASSOIOBMO

# CHEF WHIP

## Sifone per panna Cream whipper

Lo Chef Whip è adatto per la preparazione veloce di panna montata, spugne mousse, dolci, schiume fredde e salse calde e fredde, oltre ad essere ideale per guarnire cappuccini, caffè, dolci e gelati.

The Chef Whip is suitable for the quick preparation of whipped cream, mousse sponges, sweets, cold foams and hot and cold sauces, as well as being ideal for garnishing cappuccinos, coffee, sweets and ice creams.



Il kit comprende: bottiglia, testata, 3 beccucci e porta capsule in acciaio. Guarnizione di testata in silicone.

The kit includes: bottle, head, 3 spouts and steel capsule holder. Silicone head gasket.

**500 ml**

**50SI01**

Sifone per panna  
Cream whipper

**1000 ml**

**50SI02**

Sifone per panna  
Cream whipper



**RICARICHE PER SIFONE  
CREAM CHARGES**

**50SIRO1**

Cartucce per sifone panna NO2  
NO2 cream whipper cartridges  
Pack 10 pcs

# PISTON FUNNEL

**Dosatori professionali in acciaio inox** ideale per dosare piccole quantità di prodotto nei bicchierini o negli appositi stampi, in modo **facile e senza sprechi**. Ottimo per salse, gelatine, crème brûlée e marmellate liquide, è fornito di un set di bocchette per una migliore applicazione.

**Professional stainless steel funnel** ideal for dosing small quantities of product in small cups or in the suitable moulds, in an **easy and waste-free way**. Excellent for sauces, jellies, crème brûlée and liquid jams, it is equipped with a set of nozzles for a better application.



## 50C0001 800 ml

Colino professionale completo: la confezione comprende un piedistallo in metallo e tre bocchette da Ø 2 - 4 - 5 mm.  
Complete professional funnel: packaging includes a metal support and three nozzles: Ø 2 - 4 - 5 mm.



## 50C0002 1900 ml

Colino professionale completo: la confezione comprende un piedistallo in metallo e tre bocchette da Ø 4 - 5 - 6 mm.  
Complete professional funnel: packaging includes a metal support and three nozzles: Ø 4 - 5 - 6 mm.

## GRIGNOTTINA - COOKIES MAKER

Strumento per creare velocemente ed in modo preciso "roches", biscotti e altri dolci.

Composto da: 1 telaio in plastica senza fondo - 2 teglie forate (Ø30 - 40 mm) - 1 spatola in plastica

Dosing tool to quickly and precisely create "roches", biscuits and other sweets.

Composed of: 1 plastic saucepan without bottom - 2 perforated trays (Ø30 - 40 mm) - 1 plastic spatula

### CIOK 1

60x40 h5 cm



## RIFRATTOMETRO - REFRACTOMETER

Rifrattometro ottico universale con scala 0-90% Brix, in grado di misurare con precisione, la concentrazione percentuale di sostanze solide, come lo zucchero, in una soluzione fluida.

Universal optical refractometer with 0-90% Brix scale, able to accurately measure the percentage concentration of solid substances, such as sugar, in a fluid solution.

### 5ORIO1

Ø3,8 X 14 cm  
0-90 % BRX



## BILANCE - SCALES

Precise e facili da usare: pannello touch, funzione tara, indicazione di sovraccarico, indicatore di bassa potenza.  
Precise and easy to use: touch panel, tare function, overload indication, low power indicator.



### Bilancia piccola - Small scale

#### 50BI01

Superficie in vetro temperato  
Tempered glass surface  
Div 1g - 0,05oz / 1ml (1/8cup) - max 5 Kg  
Batterie incluse - Batteries included  
Misura - Size: 22 x 16 cm



### Bilancia grande - Big scale

#### 50BI02

Superficie in acciaio inossidabile  
Stainless steel surface  
Div 1g - 0,05oz - max 15 Kg  
Batterie incluse - Batteries included  
Misura - Size: 26 x 31 cm

## TERMOMETRI - THERMOMETERS

Termometri digitali con sonda o ad infrarossi precisi e funzionali.  
Precise and functional thermometers with probe or infrared technology.



### Termometro elettronico Electronic thermometer

#### 50T001

Sonda ad immersione  
Dipping probe  
Celsius -50°C / 300°C  
Fahrenheit -58°F / 572°F



### Termometro ad infrarossi Infrared thermometer

#### 50T002

LCD display  
Celsius -50°C / 420°C  
Fahrenheit -58°F / 788°F



### Termometro digitale Digital thermometer

#### 50T003

Sonda ad immersione - Display e Timer  
Dipping probe - Display and Timer

Celsius 0°C / 250°C  
Fahrenheit -32°F / 482°F

# CONTAINERS

## ISOTHERMAL



### GASTRONORM

**50CI540GN**

Cap. 83 Lt

Internal size: 54 x 33 x 48 cm

External size: 65 x 50 x 61 cm

### 50X50

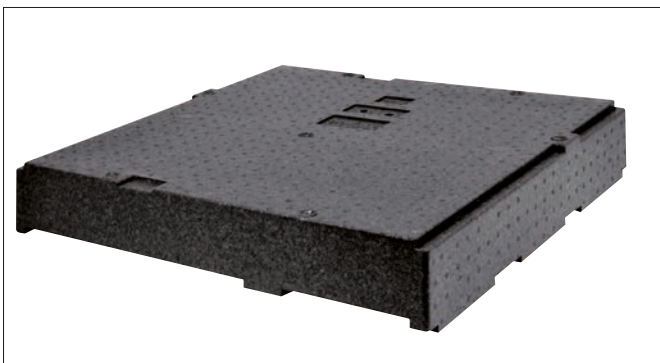

**Terminale  
End piece**

**50CI5050BC**

Internal size: 510x510x63 mm  
External size: 570x570x95 mm

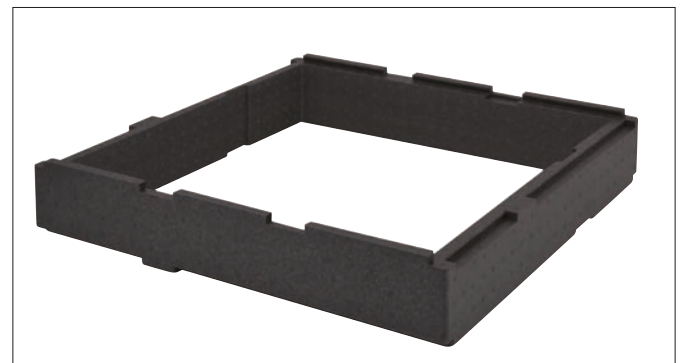

**Estensore  
Extensor**

**50CI5050ES**

Internal size: 510x510x95 mm  
External size: 570x570x95 mm



**Piastra eutettica  
Eutectic plate**  
-12°C / 0°C

**50CIA007**

Size: 60 x 40 x 3 cm



**Piastra eutettica  
Eutectic plate**  
-6°C / 0°C

**50CIA008**

Size: 38 x 21,5 x 3 cm

## PLASTIC BOX



**Cassa fondo chiuso senza maniglie**  
**Closed bottom case without handles**

**50CA604007C**

Cap. 12 Lt - 60 x 40 h 7 cm

**50CA604010C**

Cap. 18 Lt - 60 x 40 h 10 cm



**Cassa fondo chiuso con maniglie**  
**Closed bottom case with handles**

**50CA604013C**

Cap. 24 Lt - 60 x 40 h 13 cm



**Coperchio per casse 60 x 40**  
**Crate lid 60 x 40**

**50CA6040COP**

60 x 40 cm



# PROFESSIONAL TOOLS

# Mart Poche



UNA LINEA COMPLETA DI SAC À POCHE MONOUSO  
A COMPLETE LINE OF DISPOSABLE PASTRY BAGS

MADE IN ITALY by MARTELLATO



RESISTENTI, ANTISCIVOLO, IGIENICHE, FACILI  
DA UTILIZZARE, CON SALDATURA SOTTILE  
RESISTANT, NON-SLIP, HYGIENIC, EASY TO USE,  
WITH THIN SEAL

## ALTA QUALITÀ MADE IN ITALY

Pensate per facilitare il lavoro quotidiano dei professionisti grazie alle caratteristiche dei diversi modelli, le sac à poche monouso Martellato sono conosciute ed apprezzate in tutto il mondo. La produzione è interamente italiana, dalla materia prima accuratamente selezionata alla lavorazione, sotto l'attento controllo di Martellato che, grazie all'impiego delle più **moderne tecnologie** e nel rispetto delle direttive internazionali, è in grado di offrire **sacchetti di alta qualità**.

### I NOSTRI PLUS

Velocità e precisione, **presa sicura antiscivolo e alta resistenza**, fanno delle sac à poche prodotte da Martellato un prezioso alleato di pasticceri e chef. Un'**unica saldatura, più sottile** per consentire maggiore praticità e **più resistente** per evitarne la rottura durante l'uso, insieme al **materiale multistrato di alta qualità**, garantiscono la durata delle sac à poche per molto tempo, consentendo di riempirle più volte durante l'utilizzo. Possono essere utilizzate con composti caldi e freddi, duri o morbidi e sono adatte per l'utilizzo sia in abbattitore che in microonde.

---

## HIGH QUALITY MADE IN ITALY

Designed to facilitate the daily work of professionals thanks to the characteristics of the different models, the Martellato disposable pastry bags are known and appreciated all over the world.

The production of the pastry bags is entirely Italian, from the raw material to processing, under the careful control of Martellato that, thanks to the use of the most **modern technologies** and in compliance with international directives, can offer **high quality bags**.

### OUR PLUS

Speed and precision, non-slip **secure grip** and **high resistance**, make the pastry bags produced by Martellato a precious ally of both confectioners and chefs. **A single seall, thinner** for improved practicality and more resistant to prevent any breakage during use, together with the high quality **multi-layered material**, guarantee these pastry bags last over time, allowing to fill them over and over again during the use. They can be used with hot or cold, hard or soft preparations and are suitable for refrigerators and microwave ovens.

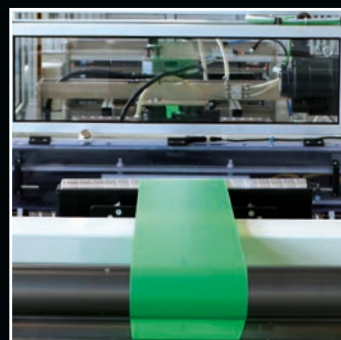
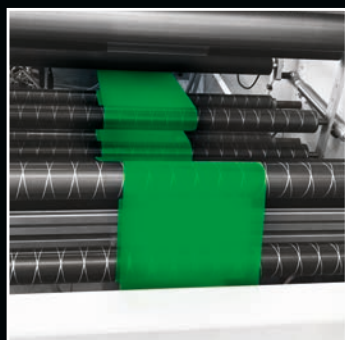

**Soft touch:** funzionalità e comfort  
**Soft touch:** functionality and comfort

# Blue Poche

MADE IN ITALY by MARTELLATO

EXTRA  
COMFORT

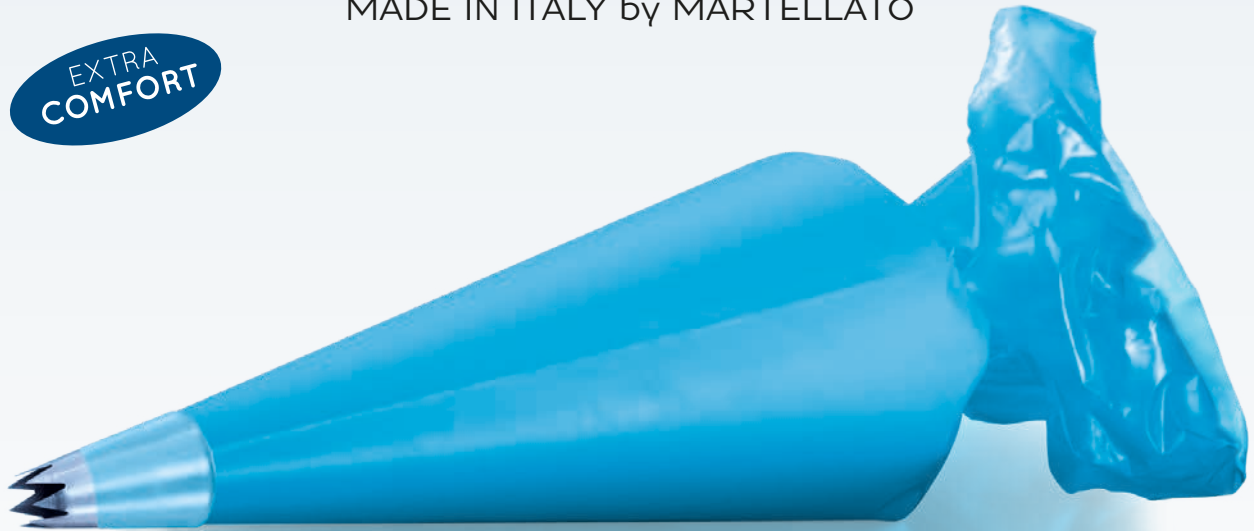

Sacchetti monouso in polietilene multistrato, danno una **piacevole sensazione al tatto** e **maggiore flessibilità**. L'interno liscio facilita la fuoriuscita dei composti caldi, freddi, duri o morbidi.

Disposable pastry bags in multi-layered polyethylene, they give a **pleasant sensation at the touch** and **greater flexibility**. The slick interior facilitates the release of doughs, whether hot, cold, hard or soft.

MYCRON  
**80**  
MY



**H 30 CM**  
**50-2030**  
Dispenser box  
100 pcs

**H 40 CM**  
**50-2040**  
Dispenser box  
100 pcs

**H 55 CM**  
**50-2055**  
Dispenser box  
100 pcs

**H 65 CM**  
**50-2065**  
Dispenser box  
100 pcs

**Antiscivolo, resistente e sicuro:** massima qualità  
**Resistant, non-slip and safe:** top quality

# Green Poche

MADE IN ITALY by MARTELLATO

GRIP  
EFFECT



Sacchetti monouso in polietilene **multistrato** verde con rivestimento **antiscivolo all'esterno** pensato per assicurare, anche con mani umide, una presa sicura. All'interno, invece, la superficie è liscia per consentire al prodotto di uscire facilmente.

Disposable pastry bags in green multilayer polyethylene with non-slip coating on the outside designed to ensure a secure grip, even with wet hands. Inside, however, the surface is smooth to allow the product to come out easily.

MYCRON  
**80**  
MY



**H 30 CM**  
**50-1030**  
Dispenser box  
100 pcs

**H 40 CM**  
**50-1040**  
Dispenser box  
100 pcs

**H 55 CM**  
**50-1055**  
Dispenser box  
100 pcs

**H 65 CM**  
**50-1065**  
Dispenser box  
100 pcs

**H 30 CM**  
**50103020STD**  
Roll 20 pcs

**H 40 CM**  
**50104020STD**  
Roll 20 pcs

**H 55 CM**  
**50105520STD**  
Roll 20 pcs

**Trasparente, super resistente:** un alleato indispensabile nel tuo laboratorio  
**Transparent, super-resistant:** an indispensable help in your laboratory

# Crystal Poche

MADE IN ITALY by MARTELLATO

**SUPER  
RESISTANT**



Sacchetti monouso in polietilene **trasparente extra forte**, adatti anche per gli impasti più duri e **riempibili numerose volte**.

**Extra-strong, transparent** polyethylene disposable pastry bags, suitable for even the toughest mixes and can be filled many times over.

MYCRON  
**80**  
MY



**H 30 CM**  
**ROLL H 30**  
 Dispenser box  
 100 pcs

**H 40 CM**  
**ROLL H 40**  
 Dispenser box  
 100 pcs

**H 55 CM**  
**ROLL H 55**  
 Dispenser box  
 100 pcs

**H 65 CM**  
**ROLL H 65**  
 Dispenser box  
 100 pcs

**H 30 CM**  
**ROLLH3020STD**  
 Roll 20 pcs

**H 40 CM**  
**ROLLH4020STD**  
 Roll 20 pcs

**H 55 CM**  
**ROLLH5520STD**  
 Roll 20 pcs

Sac à poche monouso pretagliati per alimenti in polietilene trasparente, **spessore 80 micron**.  
 Disposable precut pastry bags for food made of transparent polyethylene, **80 microns thick**.

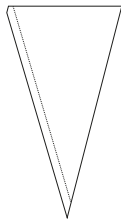

Confezionati in cartone con euroforo.

Size cm	pcs box	Code
23x45	100	SAC45X100

Packed in cardboard boxes with euro-perforation.

Size cm	pcs box	Code
30x55	100	SAC58X100

## PORTA SAC À POCHE / PASTRY BAG HOLDER

**Vaso porta sac à poche:** Accessorio ideale per riporre la sac à poche in uso.

**Pastry bag holder:** Ideal accessory for storing the pastry bag in use.



**50VA001A**  
 Ø200 - h240 mm  
 Arancione - Orange



**50VA001V**  
 Ø200 - h240 mm  
 Verde - Green

# SuperFlex

Simply **unbreakable!**

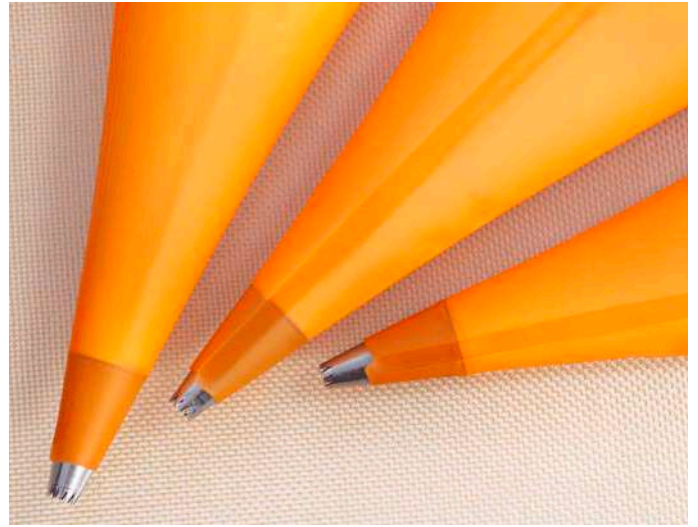
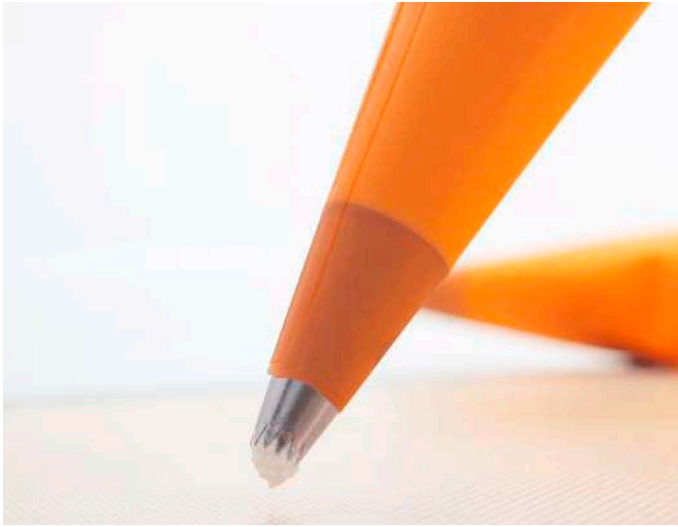

## SACCHETTI PER PASTICCERIA RIUTILIZZABILI

Superflex presenta una superficie liscia all'interno, che facilita la fuoriuscita del prodotto, e ruvida all'esterno, per garantire un'impugnatura più sicura. **Elevatissima resistenza alla trazione e facilità di lavaggio** e pulizia, conferiscono una durata di molto superiore a quella degli altri sacchetti in commercio, che utilizzano materiali diversi. Grazie allo **speciale sistema di saldatura del sacchetto**, l'igiene è maggiormente garantita. Non trattiene né assorbe lo sporco e l'impermeabilizzazione è resistente nel tempo, non essendo soggetta ad usura. Resiste fino a 100°C ed è adatto al microonde.

## REUSABLE PASTRY BAGS

Superflex has a inner smooth surface which facilitates the release of the cream, and a rough one on the outside in order to ensure a safer handle. **Very tensile strong and easy to wash and clean**, they give a much longer durability than other bags on the market, made of different materials.

Thanks to the **special sealing system of the bag**, hygiene is highly guaranteed. As not subject to wear, the pastry bag neither retain nor absorb dirt and the waterproofing will be resistant over time.

It resists up to 100°C and is suitable for microwave use.



Con Imballo - With package

**34 CM**

**SPR034/C**

**45 CM**

**SPR045/C**

**50 CM**

**SPR050/C**

Senza Imballo - Unpacked

**34 CM**

**SPR034**

**45 CM**

**SPR045**

**50 CM**

**SPR050**



# COTTON

Sacchetti per pasticceria riutilizzabili, prodotti con fibre naturali di **cotone** rivestito di poliuretano per dare maggiore resistenza alla pressione, con asola e **punta rinforzata**.  
**Ideali per impasti più duri.**

Reusable pastry bags made of **natural cotton** fibers coated with polyurethane to give greater resistance to pressure. Turned and sewed rimes, **reinforced tip**.  
**Ideal for harder doughs.**



Size cm	Code
25	STD 025 CM
28	STD 028 CM
34	STD 034 CM
40	STD 040 CM
46	STD 046 CM
50	STD 050 CM
55	STD 055 CM
60	STD 060 CM
65	STD 065 CM
70	STD 070 CM
75	STD 075 CM

# FLEX

Sacchetti per pasticceria riutilizzabili, prodotti con fibre di **poliestere** rivestite di poliuretano, con asola.

Reusable pastry bags made of polyurethane coated **polyester** fibers, with welded seam.



Size cm	Code
25	FLEX 025 CM
28	FLEX 028 CM
34	FLEX 034 CM
40	FLEX 040 CM
46	FLEX 046 CM
50	FLEX 050 CM
55	FLEX 055 CM
60	FLEX 060 CM
65	FLEX 065 CM
70	FLEX 070 CM

# Piping tips

Ampia gamma di bocchette in acciaio inox prodotte senza saldature per garantire la massima resistenza  
Wide range of stainless steel nozzles produced without welding to guarantee maximum resistance

pack 5 pezzi - pieces

Dove non espressamente indicato le confezioni si intendono da **5 pezzi** - le misure sono in millimetri  
If not indicated, the package contains **5 pieces** - the measurements are in millimeters

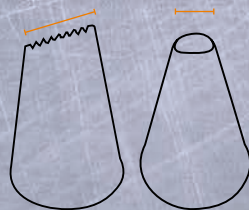
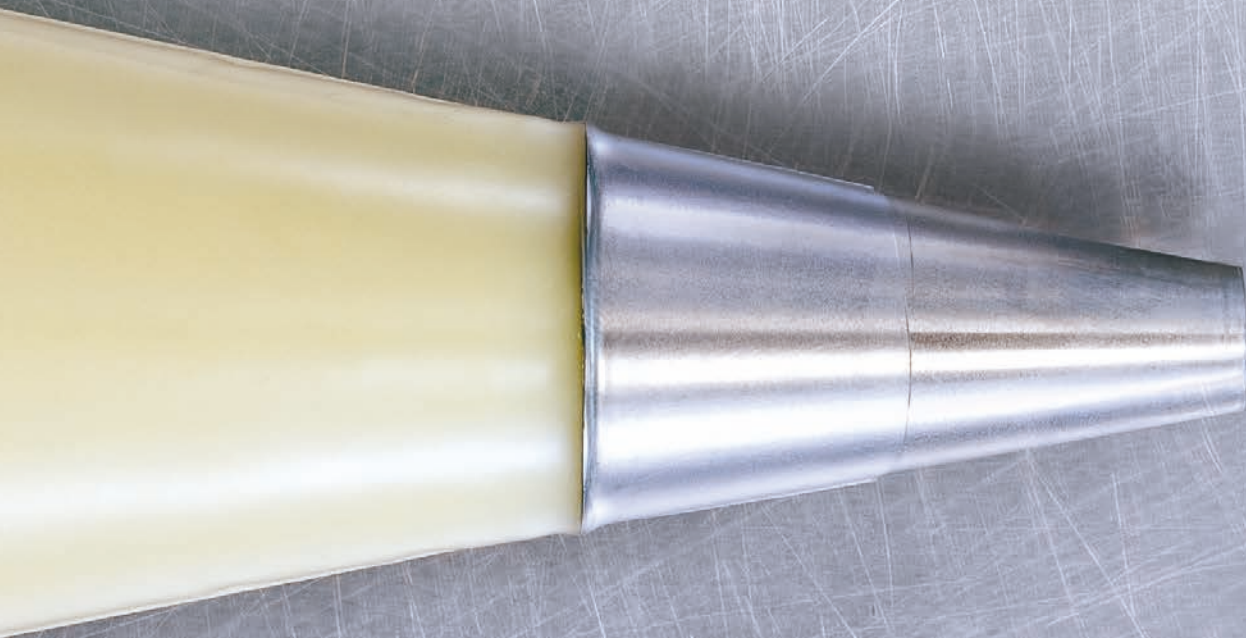

**TIP**

misura foro di uscita  
spout hole size



misure esterne  
external size

# TONDA - ROUND

Pack 5 pcs



KIT 10 pcs Mix - Ø 4 - 5 - 6 - 7 - 8 - 9 - 10 - 12 - 13 - 15 mm  
BS 10 T

<b>TIP Ø2</b> BT 202 Ø25 h 50	<b>TIP Ø3</b> BT 203 Ø25 h 50	<b>TIP Ø4</b> BT 204 Ø25 h 45	<b>TIP Ø5</b> BT 205 Ø25 h 45	<b>TIP Ø6</b> BT 206 Ø25 h 45
<b>TIP Ø7</b> BT 207 Ø25 h 45	<b>TIP Ø8</b> BT 208 Ø25 h 45	<b>TIP Ø9</b> BT 209 Ø25 h 45	<b>TIP Ø10</b> BT 210 Ø30 h 50	<b>TIP Ø11</b> BT 211 Ø30 h 50
<b>TIP Ø12</b> BT 212 Ø30 h 47	<b>TIP Ø13</b> BT 213 Ø30 h 47	<b>TIP Ø14</b> BT 214 Ø30 h 47	<b>TIP Ø15</b> BT 215 Ø35 h 50	<b>TIP Ø16</b> BT 216 Ø35 h 50
<b>TIP Ø17</b> BT 217 Ø35 h 50	<b>TIP Ø18</b> BT 218 Ø35 h 50	<b>TIP Ø20</b> BT 220 Ø35 h 47	<b>TIP Ø22</b> BT 222 Ø35 h 47	<b>TIP Ø24</b> BT 224 Ø35 h 43

# STELLA APERTA - OPEN STAR

Pack 5 pcs



KIT 10 pcs Mix - Ø 4 - 5 - 6 - 7 - 8 - 9 - 10 - 12 - 13 - 15 mm  
BS 10 S

<b>TIP Ø2</b> BS 102 Ø25 h 50	<b>TIP Ø3</b> BS 103 Ø25 h 50	<b>TIP Ø4</b> BS 104 Ø25 h 50	<b>TIP Ø5</b> BS 105 Ø25 h 50	<b>TIP Ø6</b> BS 106 Ø25 h 45
<b>TIP Ø7</b> BS 107 Ø25 h 50	<b>TIP Ø8</b> BS 108 Ø25 h 45	<b>TIP Ø9</b> BS 109 Ø25 h 40	<b>TIP Ø10</b> BS 110 Ø30 h 50	<b>TIP Ø11</b> BS 111 Ø30 h 50
<b>TIP Ø12</b> BS 112 Ø30 h 50	<b>TIP Ø13</b> BS 113 Ø30 h 50	<b>TIP Ø14</b> BS 114 Ø35 h 55	<b>TIP Ø15</b> BS 115 Ø35 h 50	<b>TIP Ø16</b> BS 116 Ø35 h 50
<b>TIP Ø17</b> BS 117 Ø35 h 50	<b>TIP Ø18</b> BS 118 Ø35 h 50			

# STELLA FRANCESE - FRENCH STAR

Pack 5 pcs



<b>TIP Ø4</b> BF 310 Ø25 h 45	<b>TIP Ø6</b> BF 311 Ø25 h 45	<b>TIP Ø7</b> BF 312 Ø25 h 45	<b>TIP Ø9</b> BF 313 Ø25 h 45	<b>TIP Ø10</b> BF 314 Ø30 h 50
<b>TIP Ø11</b> BF 314/11 Ø30 h 50	<b>TIP Ø12</b> BF 315 Ø30 h 45	<b>TIP Ø13</b> BF 316 Ø30 h 50	<b>TIP Ø15</b> BF 317 Ø35 h 50	<b>TIP Ø16</b> BF 318 Ø35 h 50
<b>TIP Ø18</b> BF 319 Ø35 h 50	<b>TIP Ø16</b> BF 0867 Ø35 h 50	<b>TIP Ø20</b> BF 0869 Ø35 h 48		

# STELLA CHIUSA - CLOSED STAR

Pack 5 pcs



<b>TIP Ø2</b> BC 320 Ø25 h 47	<b>TIP Ø3</b> BC 321 Ø25 h 47	<b>TIP Ø4</b> BC 322 Ø25 h 47	<b>TIP Ø5</b> BC 323 Ø25 h 47	<b>TIP Ø6</b> BC 324 Ø25 h 43
<b>TIP Ø7</b> BC 325 Ø35 h 50	<b>TIP Ø8</b> BC 326 Ø30 h 50	<b>TIP Ø9</b> BC 327 Ø30 h 50	<b>TIP Ø10</b> BC 328 Ø35 h 53	<b>TIP Ø11</b> BC 329 Ø35 h 50
<b>TIP Ø12</b> BC 330 Ø35 h 50				

# FANCY PIPING NOZZLES



**TIP 05**  
BX 1820 - Ø30 H 42



**TIP 023**  
BX0001 - Ø37 H 42



**TIP 023**  
BX0009 - Ø37 H 42



**TIP 020**  
BX 0252 - Ø30 H 40



**TIP 020**  
BX 0250 - Ø30 H 40



**TIP 0,4**  
BX0028 - Ø18 H 37



**TIP 0,6**  
BX0029 - Ø18 H 35



**TIP 0,9**  
BX0030 - Ø18 H 36



**TIP 04**  
BX0031 - Ø18 H 34



**TIP 4x4**  
BX0032 - Ø18 H 34



**TIP 3x3**  
BX0033 - Ø18 H 33



**TIP 5x5**  
BX0034 - Ø18 H 33



**TIP 08**  
BX0038 - Ø18 H 28



**TIP 09**  
BX0047 - Ø18 H 26



**TIP 05**  
BX0042 - Ø18 H 30



**TIP 07**  
BX0045 - Ø18 H 31



**TIP 010**  
BX0046 - Ø18 H 30



**TIP 02**  
BX0048 - Ø18 H 30

# BASKET PIPING NOZZLES



**TIP 17**  
BX 9017  
Ø30 h 50



**TIP 20**  
BX 9022  
Ø30 h 45



**TIP 16x2**  
BD 300  
Ø25 h 40



**TIP 20x3**  
BD 301  
Ø30 h 43



**TIP 27**  
BD 302  
Ø35 h 45

# STRIPES & BORDER



**TIP Ø10**  
BX9990 - Ø30 H 50



**TIP Ø12**  
BX9991 - Ø30 H 50



**TIP Ø14**  
BX9992 - Ø30 H 50



**TIP Ø13 L20**  
BX 2312 - Ø25 H 40



**TIP Ø12 L16**  
BX 2314 - Ø25 H 40



**TIP Ø14 L20**  
BX 2315 - Ø30 H 45



**TIP Ø13 L25**  
BX 1510 - Ø30 H 45



**TIP 16**  
BX 1303 - Ø25 H 40



**TIP 18x4**  
BX 1217 - Ø25 H 37



**TIP 20x7**  
BX 1405 - Ø25 H 40



**TIP 16x2**  
BX 0116 - Ø25 H 40



**TIP 19x2**  
BX 0119 - Ø25 H 40



**TIP 12x3**  
BX 1906 - Ø35 H 45



**TIP 15x2**  
BX 0134 - Ø25 H 42



**TIP Ø5**  
BX 3005 - Ø35 H 50



**TIP 15x5**  
BX 0158 - Ø25 H 45



**TIP 25**  
BX0026  
Ø18 h 36



**TIP 25**  
BX0027  
Ø18 h 36



**TIP Ø5**  
BX0039  
Ø18 h 32



**TIP 10**  
BX0043  
Ø18 h 28



**TIP Ø6**  
BX0040  
Ø18 h 30



**TIP Ø8**  
BX0044  
Ø18 h 28



**TIP Ø7**  
BX0049  
Ø18 h 30



**TIP 9**  
BX 8019  
Ø17 h 28

pack 5 pezzi - pieces

# FLOWER & PETALS NOZZLES

Pack 5 pcs



**TIP 03 - BX 0190**  
Ø25 h 43



**TIP 05 - BX 4014**  
Ø25 h 45



**TIP 13 - BX 1013**  
Ø25 h 43



**TIP 13 - BX 0108**  
Ø25 h 40



**TIP 15 - BX 5017**  
Ø30 h 43



**TIP 06 - BX 6018**  
Ø30 h 45



**TIP 18 - BS 0F6K**  
Ø30 h 45



**TIP 6 - BS 0D6K**  
Ø25 h 42



**TIP 13 - BA 413**  
Ø30 h 47



**TIP 15 - BA 415**  
Ø35 h 53



**TIP 05 - BX 0510**  
Ø25 h 42



**TIP 10 - BX 7020**  
Ø30 h 45



**TIP 06 - BS 0195**  
Ø25 h 42



**TIP 10 - BS 0195K**  
Ø25 h 40



**TIP 08 - BC 0855**  
Ø30 h 45



**TIP 15 - BR 330**  
Ø30 h 50



**TIP 08 - BX 2013**  
Ø25 h 40



**TIP 20 - BR 331**  
Ø30 h 45



**TIP 08 - BR 332**  
Ø35 h 50



**TIP 11 - BA 411**  
Ø30 h 50



**TIP 17 - BX 0123**  
Ø24 h 40



**TIP 13x2 - BX 0120**  
Ø24 h 43



**TIP 17x2**  
**BX 1105**  
Ø25 h 40



**TIP 18**  
**BX 1115**  
Ø25 h 50



**TIP 16**  
**BX 1123**  
Ø25 h 40



**TIP 14**  
**BX 1132**  
Ø25 h 40



**TIP 8**  
**BX 1605**  
Ø25 h 45



**TIP 10**  
**BX0041**  
Ø18 h 34



**TIP 5x1**  
**BX0035**  
Ø18 h 35



**TIP 7x1,5**  
**BX0036**  
Ø18 h 35



**TIP 10x3**  
**BX0037**  
Ø18 h 33

# piping tips Floreal

Pack 5 pcs



**BX 2117**  
Ø25 h 40 TIP Ø1



**BX 1713**  
Ø25 h 40 TIP Ø2



**BX0012**  
Ø37 h 42 TIP Ø23



**BX 2219**  
Ø30 h 40 TIP Ø2



**BX0002**  
Ø37 h 42



**BX0004**  
Ø37 h 42



**BX0006**  
Ø37 h 42



**BX0008**  
Ø37 h 42



**BX0011**  
Ø37 h 42



**BX0014**  
Ø37 h 42



**BX0016**  
Ø37 h 42



**BX0017**  
Ø37 h 42



**BX0023**  
Ø37 h 42



**BX0051**  
Ø35 h 38



**BX0052**  
Ø35 h 38



**BX0053**  
Ø35 h 38



**BX0054**  
Ø37 h 42



**BX0055**  
Ø37 h 42



**BX0056**  
Ø37 h 42



**BX0057**  
Ø37 h 42



**BX0058**  
Ø37 h 42



**BX0059**  
Ø37 h 42



**BX0060**  
Ø37 h 42



**BX0061**  
Ø37 h 42



**BX0062**  
Ø37 h 42



**BOS12FLO**  
Box 12 pcs



# Sphere piping tips ball



**TIP Ø22**  
**BX0100**  
Ø32 h 60 TIP Ø22  
Pack 1 pc



**TIP Ø22**  
**BX0101**  
Ø32 h 57  
Pack 1 pc



**TIP Ø22**  
**BX0102**  
Ø32 h 57 TIP Ø22  
Pack 1 pc



**TIP Ø22**  
**BX0103**  
Ø32 h 57 TIP Ø22  
Pack 1 pc



**TIP Ø22**  
**BX0104**  
Ø32 h 57 TIP Ø22  
Pack 1 pc

## FILLING NOZZLES

**TIP Ø4**  
**BIM 340**  
Ø25 h 90  
Pack 5 pcs



**TIP Ø8**  
**BIM 232**  
Ø25 h 95  
Pack 5 pcs



**TIP Ø6**  
**BIM 230**  
Ø5 h 75  
Pack 5 pcs



**TIP 31**  
**BXB01**  
Ø55 h 60 TIP Ø31  
pack 1 pc



**TIP 31**  
**BXB02**  
Ø55 h 56 TIP Ø31  
pack 1 pc



## ADAPTERS



**Piccolo - Small**  
**50AD001**  
pack 1 pc  
base Ø18 mm



**Medi - Medium**  
**50AD002**  
kit 2 pcs  
base Ø25 - Ø31 mm



**Grande - Large**  
**50AD003**  
pack 1 pc  
base Ø36 mm



**Floreal & Sphere Ball**  
**50AD004**  
pack 2 pcs  
Per bocchette a sfera e floreali  
For sphere ball and floreal tips

## Bi & Tri COLOR

Kit di adattatori, per realizzare decorazioni a due o tre colori.  
Adapter kit suitable to prepare decorations with two or three colours.



**BI & TRI COLOR**  
**40-WA010**  
pack 2 pcs  
Adatto a bocchette Ø30 h 50  
Suitable for piping tips Ø30 h 50



**Big Size**  
**BOSPL1**  
Box 12 pcs  
Plastica - Plastic



**Scatola - Box**  
**BOSPL3**  
Box 20 pcs  
Bocchette in plastica - con adattatore  
Plastic piping tips - with adapter



**Kit 6 Pezzi**  
**BPL6**  
6 pcs  
Plastica - Plastic

### Bruschino - Brush

#### BRU

Setole in nylon ed impugnatura in plastica.  
Forma conica ideale per la pulizia di tutti i modelli di bocchetta.

Nylon bristles and plastic handle.  
Conical shape ideal for cleaning all the nozzle models.





**Bocchette miste  
Mixed piping tips**

**BOS 36 BIG**

h 50 mm

il kit include:

36 bocchette miste

3 adattatori

pratica scatola in plastica

the kit includes:

36 mixed piping tips

3 adapters

practical plastic box

**Bocchette da decorazione  
Decorative piping tips**

**BOS 52**

h 33 mm

il kit include: 52 bocchette miste - 1 adattatore  
2 chiodi per fiori - pratica scatola in plastica

the kit includes: 52 mixed piping tips - 1 adapter  
2 nails for flowers - practical plastic box



**Bocchette da decorazione  
Decorative piping tips**

**BOS 26**

h 33 mm

il kit include: 26 bocchette miste - 1 adattatore  
2 chiodi per fiori - pratica scatola in plastica

the kit includes: 26 mixed piping tips - 1 adapter  
2 nails for flowers - practical plastic box





**Espositore in plexiglass  
Plexiglass display**

**ESPOB60**

Size: 515x315 h210mm  
cap. 60 bocchette/piping tips  
con crowner/with crowner



**Portabocchette in plexiglass  
con anta protettiva  
Plexiglass piping tips holder  
with protective door**

**ESPOBO32**

Size: 310x100 h390mm

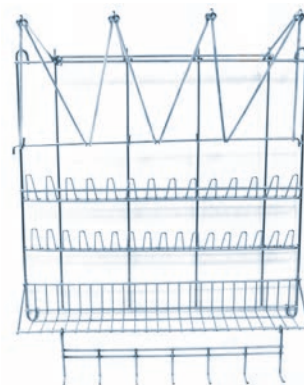

**Espositore per bocchette  
e sacchetti  
Wall rack for piping tips  
& pastry bags**

Size: 510x350 h490mm

**ESPO ST**

Inox - Stainless steel



Le più iconiche tra le sac à poche prodotte da Martellato sono proposte in una inedita confezione da 20 pezzi, per rispondere alle diverse richieste dei professionisti.

Gli esclusivi box in plexiglass ne consentiranno l'esposizione nei punti vendita o lo stoccaggio organizzato in laboratorio.

The most iconic among the Martellato's sac a poche are now available in a brand new 20-piece package, to meet the different needs of professionals.

The exclusive plexiglass boxes will allow them to be displayed at points of sale or stored in the laboratory.

**for ROLL H 30 CM**

**ESPOP30**

190x250 h 210 mm  
cap. 18 pcs

**for ROLL H 40 CM**

**ESPOP40**

250x250 h 230 mm  
cap. 18 pcs

**for ROLL H 55 CM**

**ESPOP55**

310x250 h 260 mm  
cap. 18 pcs

# TOP

## Spatula Pro

HIGH TEMPERATURE SPATULA



### 50SC350

Total 350x65 mm  
Manico/Handle 235 mm  
bianca con manico nero  
white with black handle

### 50SC400

Total 400x65 mm  
Manico/Handle 285 mm  
bianca con manico nero  
white with black handle



**Spatole professionali per alte temperature** multiuso di alta qualità con cucchiaino in silicone ed impugnatura ergonomica in plastica. Progettate per resistere alle alte temperature **fino a 230°C (446°F)**, la loro speciale impugnatura in fibra di vetro e nylon garantisce il comfort di una presa sicura durante l'uso.

**High temperatures Spatulas**, high quality, professional and multi-purpose with silicone blade and ergonomic nylon handle. That spatulas are designed to resist heat **up to 230°C (446°F)**. The sure-grip handle ensures a solid grip during use, increasing safety while maintaining comfort.

# SPATOLE MORBIDE IN PLASTICA

## SOFT PLASTIC SPATULAS

Spatola professionale bicomponente con cucchiaino in gomma e manico in ABS.  
Resistente a temperature **fino a 70°C**.  
Professional two-component spatula with rubber spoon and ABS handle.  
Temperature resistant **up to 70°C**.



### 50GO300

Manico - Handle 195 mm  
Total size 310x70 mm  
bianca - white

### 50GO350

Manico - Handle 235 mm  
Total size 350x70 mm  
bianca - white

### 50GO400

Manico - Handle 285 mm  
Total size 400x70 mm  
bianca - white



### 50GO275

Manico - Handle 187 mm  
Total size 275x49 mm  
bianca - white  
**extra soft**

Spatola professionale con anima interna rivestita in materiale termoplastico morbido.  
Resistente a temperature **fino a 70°C**.  
Professional spatula with internal core covered in soft thermoplastic material.  
Resistant to temperatures **up to 70°C**.



### 50SG250B

Manico - Handle 170 mm  
Total size 254x42 mm  
bianca - white

### 50SG250V

Manico - Handle 170 mm  
Total size 254x42 mm  
verde - green

### 50SG350B

Manico - Handle 237 mm  
Total size 355x59 mm  
bianca - white

Spatola professionale bicomponente con cucchiaino in gomma termoplastica e manico in plastica resistente rigida. Resistente a temperature **fino a 70°C**.  
Professional two-component spatula with thermoplastic rubber spoon and rigid resistant plastic handle. Resistant to temperatures **up to 70°C**.



### MEL 250

Manico - Handle 165 mm  
Total size 250 mm  
bianca - white

### MEL 350

Manico - Handle 235 mm  
Total size 350 mm  
bianca - white

### MEL 450

Manico - Handle 335 mm  
Total size 450 mm  
bianca - white

---

## SPATOLE RIGIDE IN PLASTICA HARD PLASTIC SPATULAS

Spatola rigida monopezzo in PP con fibre di vetro, resistente a temperature **fino a 70°C**.  
Cucchiaio rettangolare sottile, manico ergonomico con foro per l'appendimento.  
One-piece rigid spatula in PP with fiberglass, resistant to temperatures **up to 70° C**.  
Thin rectangular spoon, ergonomic handle with hole for hanging.



### 50SR340

Manico - Handle 239 mm  
Total size 339x59 mm  
bianca - white

---

Spatola rigida monopezzo, materiale ABS bianco resistente a temperature **fino a 70°C**.  
Cucchiaio rigido, tre lunghezze di manico con foro per l'appendimento.  
One-piece rigid spatula, white ABS material resistant to temperatures **up to 70°C**.  
Rigid spoon, three lengths handles with hole for hanging.



### SCM 30

Manico - Handle 195 mm  
Total size 300x55 mm  
bianca - white

### SCM 35

Manico - Handle 240 mm  
Total size 345x55 mm  
bianca - white

### SCM 40

Manico - Handle 295 mm  
Total size 400x55 mm  
bianca - white

---

Spatola rigida monopezzo, materiale ABS bianco resistente a temperature **fino a 70°C**.  
Cucchiaio liscio extra forte, punta stondata, manico ergonomico con foro per l'appendimento.  
One-piece rigid spatula, white ABS material resistant to temperatures **up to 70° C**.  
Extra strong smooth spoon, with rounded tip, ergonomic handle with hole for hanging.



### 50SP300B

Manico - Handle 208 mm  
Total size 300x48 mm  
bianca - white

### 50SP350B

Manico - Handle 254 mm  
Total size 350x53 mm  
bianca - white

### 50SP400B

Manico - Handle 301 mm  
Total size 400x58 mm  
bianca - white

---

Spatola rigida monopezzo, materiale poliammide con fibre di vetro, resistente a temperature **fino a 220°C**.

One-piece rigid spatula, polyamide with fiberglass material, resistant to temperatures **up to 220° C**.



**MEX 250**

Manico - Handle 130 mm  
Total size 250 mm  
bianca - white

**MEX 300**

Manico - Handle 180 mm  
Total size 300 mm  
bianca - white

**MEX 400**

Manico - Handle 255 mm  
Total size 400 mm  
bianca - white

**MEX 500**

Manico - Handle 290 mm  
Total size 500 mm  
bianca - white

---

Spatole con cucchiaino cavo in gomma e manico in resistente materiale termoplastica. Resistente a temperature **fino a 70°C**.

Spatulas with rubber hollow spoon and handle in resistant thermoplastic material. Resistant to temperatures **up to 70°C**.



**MSP 250**

Manico - Handle 160 mm  
Total size 250 mm  
bianca - white

**MSP 350**

Manico - Handle 260 mm  
Total size 350 mm  
bianca - white

---

Spatole professionali rigide monopezzo, materiale ABS bianco resistente a temperature **fino a 70°C**.  
One-piece hard professional spatulas, white ABS material resistant to temperatures **up to 70°C**.



**50SA150B**

Manico - Handle 180 mm  
Total size 324x40 mm  
bianca - white

**50SA250B**

Manico - Handle 180 mm  
Total size 424x40 mm  
bianca - white



**50SL300B**

Manico - Handle 156 mm  
Total size 300x30 mm  
bianca - white

**50SL370B**

Manico - Handle 161 mm  
Total size 370x40 mm  
bianca - white

# SPATOLE IN ACCIAIO ST. STEEL SPATULAS

Spatole professionali con lama dritta o angolare in acciaio inox. Lama rigida per distribuire uniformemente anche ganache più dure ma flessibile per un glassaggio ottimale. Manico realizzato in robusta plastica, ergonomico e antiscivolo, progettato con speciale appoggio per il pollice, ideale per una presa confortevole e sicura.

Professional spatulas with stainless steel straight or angular blade. Sturdy blade to spread also harder ganache but flexible for optimal glazing. Handle made of resistant plastic, ergonomic and anti-slip, with a special thumb support, for a comfortable and secure grip.



## 50SPANG01

Manico - Handle 133 mm  
Lama - Blade 32x102 mm

## 50SPANG02

Manico - Handle 133 mm  
Lama - Blade 32x155 mm

## 50SPANG03

Manico - Handle 133 mm  
Lama - Blade 32x205 mm

## 50SPANG04

Manico - Handle 133 mm  
Lama - Blade 32x255 mm



## 50SPA01

Manico - Handle 133 mm  
Lama - Blade 32x105 mm

## 50SPA02

Manico - Handle 133 mm  
Lama - Blade 32x160 mm

## 50SPA03

Manico - Handle 133 mm  
Lama - Blade 32x210 mm

## 50SPA04

Manico - Handle 133 mm  
Lama - Blade 32x260 mm

---

## FRUSTE PROFESSIONALI PROFESSIONAL WHISKS

Interamente realizzata in acciaio inox, 8 robusti fili d. 2,2 mm. Resistente ad alte temperature.  
Entirely made of stainless steel, 8 sturdy wires d. 2.2 mm. Resistant to high temperatures.

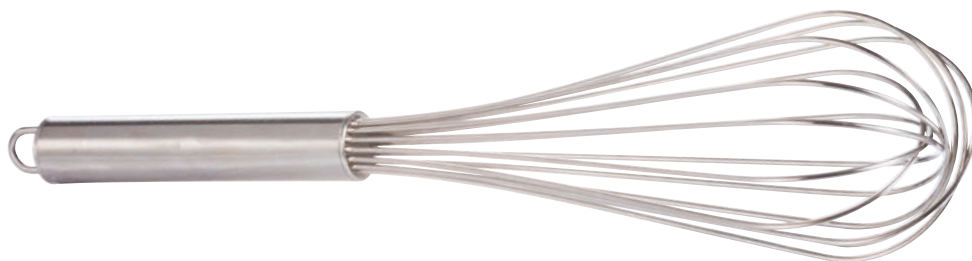

**50FA01**

Total size: 25 cm

**50FA02**

Total size: 30 cm

**50FA03**

Total size: 35 cm

**50FA04**

Total size: 40 cm

**50FA05**

Total size: 45 cm

**50FA06**

Total size: 50 cm

---

Manico antiscivolo in plastica rinforzata con fibra di vetro, 16 fili sottili in acciaio inox.  
Resistente ad alte temperature.

Glass fiber reinforced plastic non-slip handle, 16 thin stainless steel wires. Resistant to high temperatures.

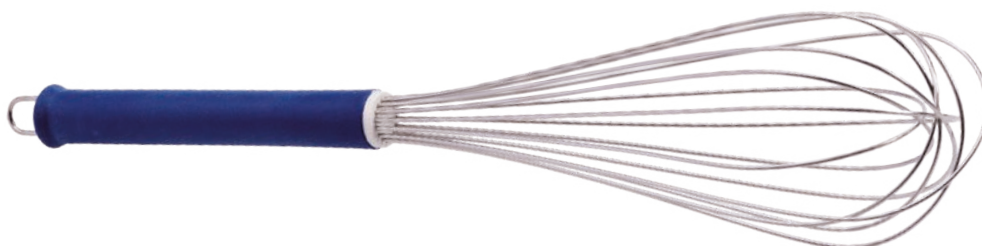

**TFRU 25**

Total size: 25 cm  
Filo - wire Ø 1,5 mm

**TFRU 30**

Total size: 30 cm  
Filo - wire Ø 1,8 mm

**TFRU 35**

Total size: 35 cm  
Filo - wire Ø 1,8 mm

**TFRU 40**

Total size: 40 cm  
Filo - wire Ø 1,8 mm

**TFRU 45**

Total size: 45 cm  
Filo - wire Ø 2 mm

**TFRU 50**

Total size: 50 cm  
Filo - wire Ø 2 mm

---

Manico in plastica rinforzata con fibra di vetro, 16 fili sottili in acciaio inox. Resistente ad alte temperature.  
Glass fiber reinforced plastic handle, 16 thin stainless steel wires. Resistant to high temperatures.



**MFRU 25**

Total size: 25 cm  
Filo - wire Ø 1,5 mm

**MFRU 30**

Total size: 30 cm  
Filo - wire Ø 1,8 mm

**MFRU 35**

Total size: 35 cm  
Filo - wire Ø 1,8 mm

**MFRU 40**

Total size: 40 cm  
Filo - wire Ø 1,8 mm

**MFRU 45**

Total size: 45 cm  
Filo - wire Ø 2 mm

**MFRU 50**

Total size: 50 cm  
Filo - wire Ø 2 mm

# Professional Choco SCRAPERS



Le nuove raschie progettate e prodotte in Italia da Martellato rispondono alle esigenze dei cioccolatieri più attenti. Composte da una robusta **LAMA RIGIDA** in **ACCIAIO INOX** e proposte in differenti misure ed altezze per le diverse esigenze: **CORTA** per una maggiore sensibilità della mano o **LUNGA** per maggiore superficie di lavoro. Il **MANICO SAGOMATO** in plastica **ANTISCIVOLO** è adatto a diverse impugnature e avvolge la lama per una completa sicurezza ed igiene.

The new scrapers designed and produced in Italy by Martellato meet the needs of the most demanding chocolatiers. Composed of a sturdy **STAINLESS STEEL RIGID BLADE** and proposed in different sizes and heights for different needs: **SHORT** for greater sensitivity of the hand or **LARGE** for greater working surface. The **ANTI-SLIP SHAPED** plastic **HANDLE** is suitable for different grips and it wraps the blade for maximum safety and hygiene.



## MODELLI - MODELS

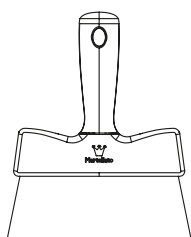

### 50RAS4

Total size: 180x145 mm  
Manico - Handle: h 130x135,4 mm  
Lama - Blade: 145 x h 50 mm

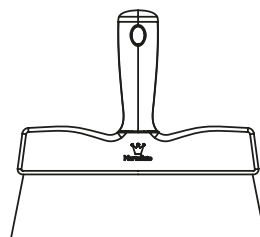

### 50RAS6

Total size: 180x200 mm  
Manico - Handle: h 130x189,7 mm  
Lama - Blade: 200 x h 50 mm

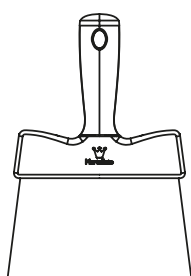

### 50RAS5

Total size: 210x145 mm  
Manico - Handle: h 130x135,4 mm  
Lama - Blade: 145 x h 80 mm

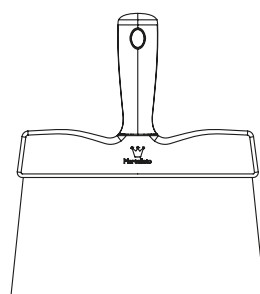

### 50RAS7

Total size: 225x200 mm  
Manico - Handle: h 130x189,7 mm  
Lama - Blade: 200 x h 95 mm

# RASCHIE IN METALLO - METAL SCRAPERS

Raschie e spatole taglia impasto con lama in acciaio inox e manico in plastica.  
Scrapers and spatulas for cutting dough with stainless steel blade and plastic handle

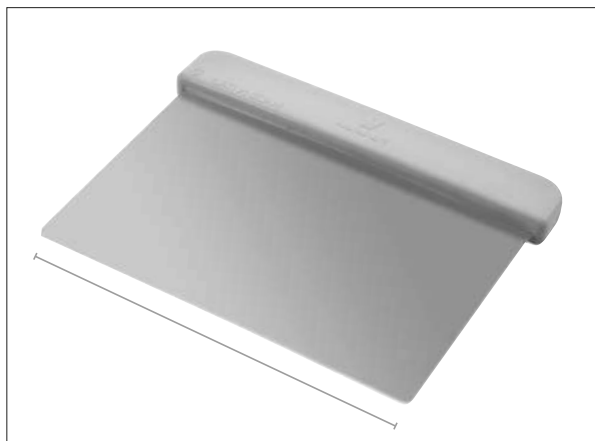

**50RAS1 50RAS2**  
130 h105 175 h105

**Lama Blade:** Acciaio inox - Stainless steel  
Spessore - Thickness 0,40 mm  
Altezza - Height 80 mm

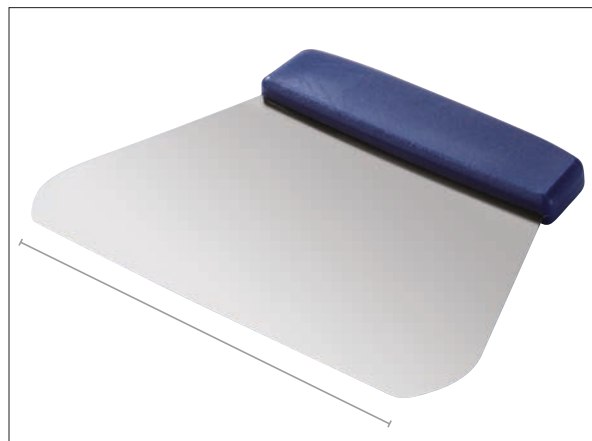

**RAS 3**  
195 h145

**Impugnatura in plastica - Plastic handle**  
**Lama Blade:** Acciaio inox - Stainless steel  
Spessore - Thickness 0,50 mm  
Altezza - Height 110 mm

## TAGLIA IMPASTO - DOUGH CUTTERS

Spatole taglia impasto con impugnatura rotonda

Acciaio inox - Stainless steel  
Altezza - Height 80 mm

Acciaio inox - Stainless steel  
Altezza - Height 60 mm

Acciaio inox - Stainless steel  
Altezza - Height 60 mm

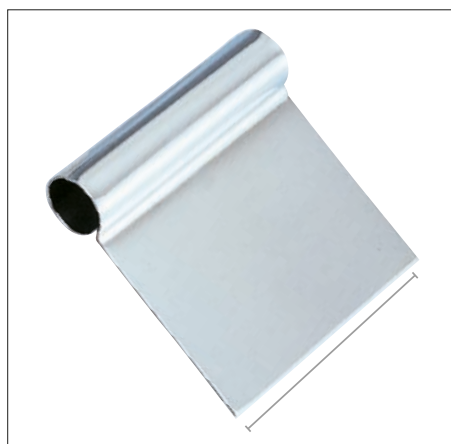

**RD105 RD125**  
105 x h105 125x h105

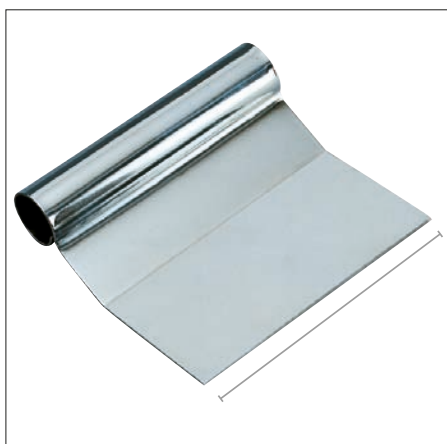

**RC115**  
120 x h115



**RD150 RD175**  
150 x h105 175 x h105

**RD150 RD175**  
150 x h105 175 x h105

# — RASCHIETTI IN PLASTICA - PLASTIC SCRAPERS —

Raschietti in plastica per creme ed altri impasti. Confezioni 10 pezzi.

Plastic scrapers for creams and other doughs. Packs of 10 pcs.



**145x95 MM**

**50RTD1**

Rigido - Rigid



**150x110 MM**

**50RTF1**

Rigido - Rigid

**50RTF2**

Morbido - Soft



**145x95 MM**

**50RTL1**

Rigido - Rigid

**50RTL2**

Morbido - Soft



**120x90 MM**

**50RTP1**

Rigido - Rigid

**50RTP2**

Morbido - Soft



**125x90 MM**

**50RTA1**

Rigido - Rigid

**50RTA2**

Morbido - Soft



**140x90 MM**

**50RTO1**

Rigido - Rigid

**50RTO2**

Morbido - Soft



**150x150 MM**

**50RTV1**

Rigido - Rigid

**50RTV2**

Morbido - Soft



**BIG SIZE**

**215x130 MM**

**50RTT1**

Rigido - Rigid



**BIG SIZE**

**195x150 MM**

**50RTS1**

Rigido - Rigid

# COLTELLI PROFESSIONALI PROFESSIONAL KNIVES

Robusta lama in acciaio inox temperato made in Italy. Manico ergonomico in polipropilene, materiale igienico, atossico e resistente in lavastoviglie. Confezione in blister sicuri.

Sturdy blade in tempered stainless steel, made in Italy. Ergonomic polypropylene handle, hygienic, non-toxic and dishwasher safe material. Secure blister packaging.



**Spelucchino 9 - Paring 9**

**50COL01**

Lama - Blade: 90mm



**Pasticceria 30 - Pastry 30**

**50COL02**

Lama - Blade: 300mm



**Cuoco 26 - Chef 26**

**50COL04**

Lama - Blade: 260mm



**Cuoco 30 - Chef 30**

**50COL05**

Lama - Blade: 300mm



**Salati e formaggi 26 - Salty and cheese 26**

**50COL06**

Lama - Blade: 260mm



**Pane e panettone 25 - Bread and panettone 25**

**50COL07**

Lama - Blade: 250mm

## PINZE CHEF CHEF TWEEZERS

Pinza professionale da cucina, caratterizzata dal design ergonomico, per una sicura e comoda maneggevolezza, che la rende adatta anche a decori e cibi più delicati.

Estremità antiscivolo, perfettamente allineate per afferrare con la massima precisione. Pratica e comoda impugnatura con grip antiscivolo, garantisce una presa sicura e ferma. Realizzata in acciaio inox di alta qualità, lavabile in lavastoviglie.

Professional cooking tweezer, the ergonomic design for safe and comfortable handling makes it suitable for delicate decorations and foods. Non-slip ends, perfectly aligned, can precisely grab small detailed items with maximum precision without slipping. Practical and comfortable thanks to the ridged handle that ensures a secure grip. Made of high quality stainless steel, dishwasher safe.



## GRATER & ZESTER

Ideale per cioccolato, formaggio, agrumi e altro. Lama in **acciaio**, manico **soft touch antiscivolo**, custodia protettiva.

Ideal for chocolate, cheese, citrus and more. **Stainless steel** blade, **non slip soft** handle, blade cover for safe storage.

Giallo - Yellow  
**50ZES01**



Rosso - Red  
**50ZES02**



Nero - Black  
**50ZES03**



## PENNELLI - PASTRY BRUSHES

**Pennello professionale per cucina:** pennello multiuso con setole di alta qualità e impugnatura in plastica combinata a gomma, per una maggiore comodità. Resistente fino a 120°C. Lavabile in lavastoviglie. Made in Italy.

**Professional cooking brush:** multi-purpose brush with high quality bristles and comfortable handle in plastic and rubber. Heat resistant up to 120°C. Dishwasher safe. Made in Italy.



**50PE30**  
30 mm

**50PE40**  
40 mm

**50PE50**  
50 mm

**50PE60**  
60 mm

**50PE70**  
70 mm

## PINZE - PINCERS



**PINZAX1**  
Pinze in acciaio inox  
St. Steel pincers  
190x17mm



**PINZAX2**  
Pinze in acciaio inox  
St. Steel pincers  
190x36mm



**PINZAX3**  
Pinze in acciaio inox  
St. Steel pincers  
190x38mm



**PINZAX4**  
Pinze in acciaio inox  
St. Steel pincers  
190x58mm

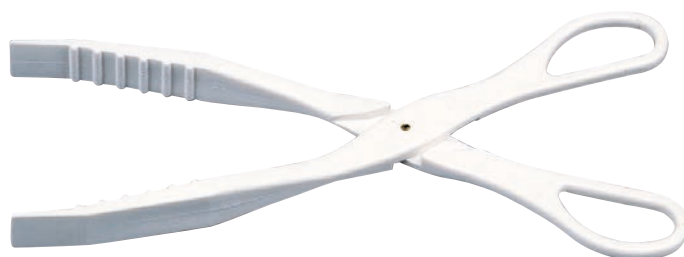

**PINZA**  
Pinza in plastica  
Plastic pincer  
295x80mm

## GRIGLIE - RACKS

Griglia di raffreddamento ideale per **glassare** e **raffreddare** torte. Resistente alle alte temperature. Cromata, con piedini per facilitare il lavoro. Lavabile in lavastoviglie.  
Cooling grid ideal for **cooling** and **glazing** cakes. Resistant to high temperatures. Made of chromed iron with raised base to facilitate work. Dishwasher safe.

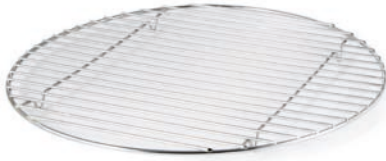

Ø30 CM  
PR30



30x30 CM  
PR30X30



60x39 CM  
PR40X60

Piedini più alti, perfetta per essere utilizzata con le teglie. Higher feet, perfect for use with trays.

Ø40 CM  
PR40

50x50 CM  
PR50X50

## SETACCI - SIEVES

Setacci in acciaio inox per farina. Trama setaccio 0,50 mm.  
Stainless steel sieves for flour. Sieve weft 0,50 mm



Ø30 CM  
SETAC30



Ø28 CM  
SETAC28



Ø26 CM  
SETAC26

Ø24 CM  
SETAC24

Ø21 CM  
SETAC21

Ø19 CM  
SETAC19

Ø16 CM  
SETAC16

### Spargi Polvere

Diffusori a maglia fine con tappo a vite. Ideali per spolverare zucchero a velo e farina o aggiungere spezie e cacao. Il coperchio a rete fine diffonde il contenuto in modo leggero e uniforme, è sicuro e facile da rimuovere per riempire di nuovo il barattolo. Realizzati in acciaio inossidabile con una copertura di plastica ermetica per proteggere il contenuto.

### Mesh Shaker

Fine mesh shakers with a screw cap. Ideal for sprinkling icing sugar and flour or adding spices and cocoa. The fine mesh lid spreads contents lightly and evenly, it is safe and easy to remove to refill the can. Made from stainless steel with an airtight plastic cover to protect the contents.

cap. 450 g  
**SETACIOK2**  
Ø73 h120mm



# TAGLIAPASTA ESTENSIBILE EXPANDABLE WHEELS CUTTER

Tagliapasta estensibile in acciaio, consente di tagliare in modo rapido e preciso strisce di impasti della stessa misura. Disponibile anche in versione doppia con lame dritte su un lato e alette scanalate sul retro. La distanza delle ruote è facilmente regolabile per ottenere strisce dai 10 ai 120 mm. Diametro ruota 5,5 cm. Le ruote possono essere bloccate nella posizione desiderata stringendo i dadi ad alette. Stoccaggio facile.

Extensible steel dough cutter, it allows to cut quickly and precisely strips of dough of the same size. Also available in double version with straight blades on one side and grooved blades on the back. The distance of the wheels is easily adjustable to obtain strips from 10 to 120 mm. Wheel diameter 5,5 cm. The wheels can be locked in the desired position by tightening the wing nuts. Easy storage.

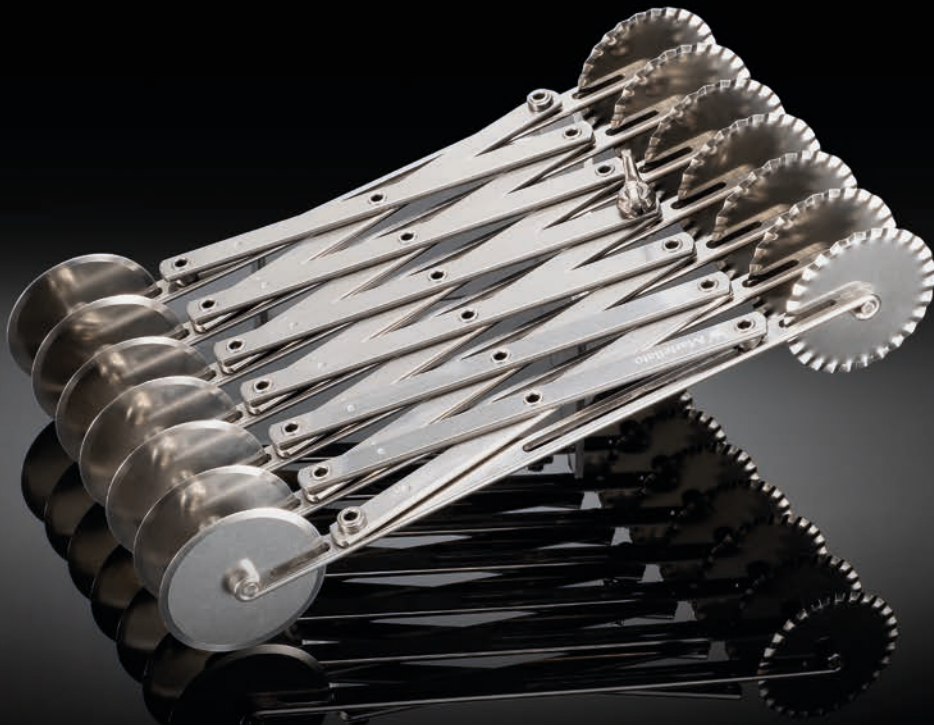

5 Lame lisce - Straight Blades  
**ROTAPINOX 5 P**



5 Lame ondulate - Curved Blades  
**ROTAPINOX 5 O**



5 Lame ondulate - Curved Blades  
5 Lame lisce - Straight Blades  
**ROTINOX 5 P/O**



7 Lame lisce - Straight Blades  
**ROTAPINOX 7 P**



7 Lame ondulate - Curved Blades  
**ROTAPINOX 7 O**



7 Lame ondulate - Curved Blades  
7 Lame lisce - Straight Blades  
**ROTINOX 7 P/O**

# RULLI FORAPASTA - CUTTING DOCKER



Rullo in plastica forapasta  
Plastic spiked roller

6 CM

RFP 6

12 CM

RFP 12



Rullo in plastica per losanghe  
Plastic lattice cutting rollers

6 CM

RPL 6

12 CM

RPL 12



Rullo in plastica a lamelle  
Plastic cutting roller

6 CM

RPS 6



Rullo forapasta in alluminio  
Aluminum spiked roller

12 CM

RFP12INOX



Rullo in acciaio inox per losanghe  
St. Steel lattice cutting roller

12 CM

RPL12INOX

Distanza tra lame 7 mm

Distance between blade 7 mm



Rotella tagliapasta  
Pastry cutters

Ø 5,5 CM

PC55

Ø 6,5 CM

PC65

Ø 10 CM

PC100

Ø 12 CM

PC120

# TAGLIA CROISSANT - CROISSANT CUTTERS

Rulli taglia croissant triangolari in acciaio inox con manico ergonomico in plastica.  
Triangular stainless steel croissant cutting rollers with ergonomic plastic handle.

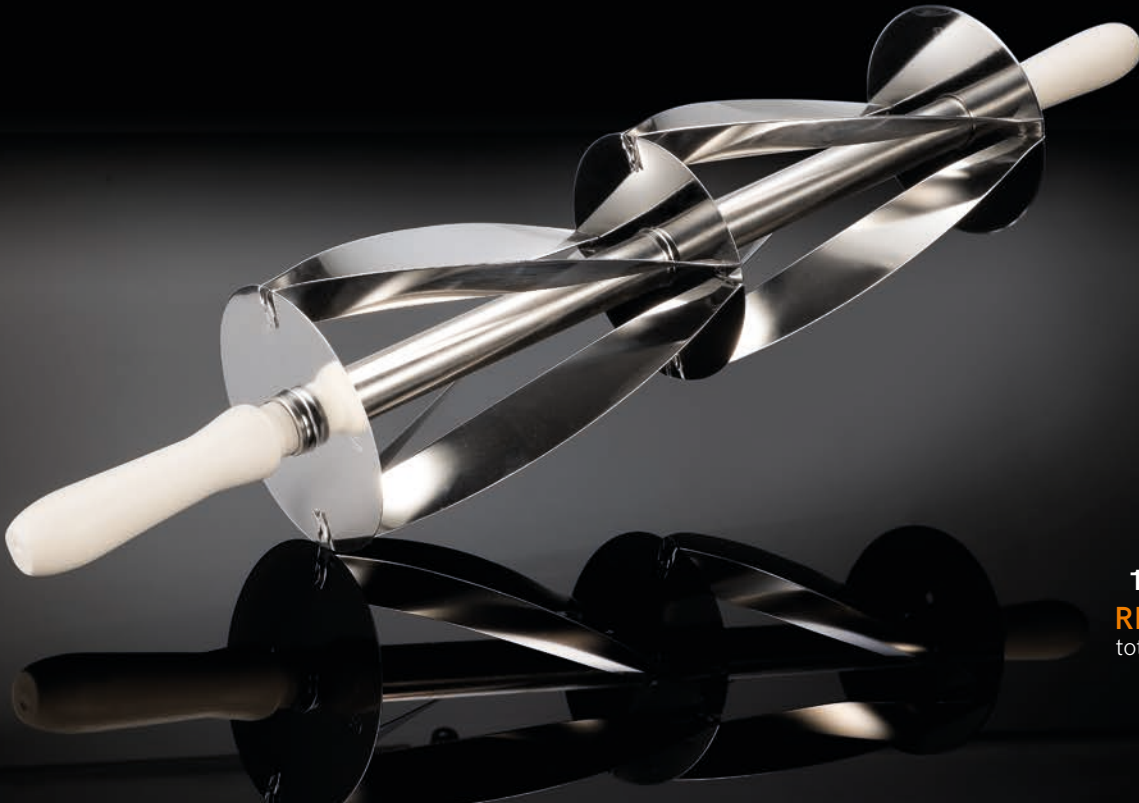

**180x200 mm**  
**RDC180X200**  
total size: 660 mm



misura di taglio **180x140 mm**  
**RSC180X140**  
total size: 400 mm

misura di taglio **96x153 mm**  
**RSC96X153**  
total size: 410 mm

misura di taglio **97x210 mm**  
**RSC97X210**  
total size: 460 mm

misura di taglio **180x200 mm**  
**RSC180X200**  
total size: 450 mm

misura di taglio **70x100 mm**  
**RSC70X100**  
total size: 360 mm



misura di taglio **180x200 mm**  
**RTC180X200**  
total size: 860 mm



La **misura del taglio** è riferita al triangolo di pasta.  
The measure of the cut refers to the triangle of dough.

# RULLI - ROLLING PINS

## Rulli di legno Wooden rolling pins



**50 CM**

**RL 1**

Ø 7CM

**50 CM**

**RL 2**

Ø 8CM

**60 CM**

**RL 3**

Ø 7CM

**60 CM**

**RL 4**

Ø 8CM

## Rulli di legno girevoli Revolving wooden rolling pins



**30 CM**

**RLS30**

Ø 8CM

**35 CM**

**RLS35**

Ø 8CM

**40 CM**

**RLS40**

Ø 8CM

**45 CM**

**RLS45**

Ø 8CM

**50 CM**

**RLS50**

Ø 8CM

**60 CM**

**RLS60**

Ø 8CM

## Rulli in polietilene Polyethylene rolling pins



**30 CM**

**RLS50PE**

Ø 7cm

**40 CM**

**RLS60PE**

Ø 7cm

**50 CM**

**RLS70PE**

Ø 7cm

## Rulli in polietilene ideali per pasta di zucchero e cioccolato Polyethylene rolling pins for sugar paste and chocolate



**23 CM**

**40-W021**

Ø 2,5cm

**35 CM**

**40-W154**

Ø 4,5cm

**50 CM**

**40-W022**

Ø 4,5cm

# QUICK DISKS

Utilizzate per ottimizzare produzione, le dime forate sono ideali per produrre perfetti dischi di pan di spagna, meringhe ed altri impasti, senza sprechi ed in poco tempo. Realizzate in plastica alimentare, resistente e lavabile in lavastoviglie, in diversi diametri.

Used to optimise production, the perforated frames are ideal for producing perfect sponge cake discs, meringues and other doughs, without waste and in a short time. Made of food-grade plastic, resistant and dishwasher-safe, in different diameters.

Spessore 8 mm - 8 mm thick



**Ø 13,5 CM**

**50DF138**

Prod 8 pcs

**Ø 15,5 CM**

**50DF158**

Prod 6 pcs

**Ø 17,5 CM**

**50DF178**

Prod 6 pcs

**Ø 19,5 CM**

**50DF198**

Prod 4 pcs

# RAPLETTE

## Raplette in plastica - Plastic spatulas

Raplette in plastica, consentono di stendere e livellare in modo veloce, preciso ed uniforme vari impasti. Perfette per lo spostamento di cremi sulle chitarre.

Plastic raplette, allow you to spread and level various mixtures quickly, precisely and evenly. Perfect for transferring cremi on guitars.



**30 CM**

**50SPB30**

x cod: 50TLMINI



**43 CM**

**50SPB43**

x cod: 50TLSPECIAL



**42 CM**

**CSMSPB40**

x cod: CSM040



**62 CM**

**CSMSPB60**

x cod: CSM060

## RAPLETTE

Raplette regolabile che consente di stendere e livellare in modo veloce, preciso ed uniforme impasti morbidi e cioccolato (anche multi-strato). Realizzata in resistente acciaio inox, conferisce al prodotto le dimensioni desiderate. La larghezza massima di stesura è 40 cm, lo spessore è variabile da 0.1 a 1.8 cm.

Adjustable Raplette for fast, precise and uniform spreading and levelling of soft dough and chocolate (also multi-layer). Made of resistant stainless steel, it gives the product the desired dimensions. The maximum spreading width is 40 cm, the thickness is variable from 0.1 to 1.8 cm.



**SPB SPECIAL**  
MISURA MASSIMA  
MAXIMUM SIZE

**40CM**

Misura esterna  
External Size: 50x18 h 6

## LEVEL

**LEVEL**  
BISCUIT & MORE

### LEVEL

#### 50LE001

max cap. 12 lt  
dimensioni/size: 480x200 h200 mm  
peso/weight: 4,3 kg  
Larghezza apertura/slot width: 380 mm  
Acciaio inox/stainless steel  
Made in Italy



### STRATIFICAZIONE PERFETTA CON LEVEL

Stendi impasto su ruote maneggevole e pratico che permette di creare rapidamente strati precisi ed uniformi, anche negli spessori più sottili. Facilita e velocizza la stesura uniforme di biscuit, pan di spagna, cioccolato e prodotti simili, scorrendo su diverse superfici, come carta forno o tappeti in silicone.

Level è progettato per razionalizzare la produzione: velocizza i tempi, semplifica i passaggi e riduce i costi.

### PERFECT LAYERING WITH LEVEL

Handy and practical wheel-mounted dough spreader that allows you to quickly create precise and regular layers, even in the thinnest thicknesses. It facilitates and speeds up the uniform spreading of biscuit, sponge cakes, chocolate and similar products, sliding on different surfaces, such as baking paper and silicone mats. Level is designed to rationalise production: it speeds up times, simplifies steps and reduces costs.

# CANNOLI MOULDS

Stampi in acciaio per la produzione di cannoli.  
Stainless steel moulds to make cannoli.



**22x140 mm**  
**50CI22X14**  
10 pcs

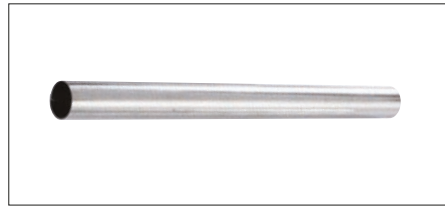

**16x200 mm**  
**50CI16X20**  
12 pcs

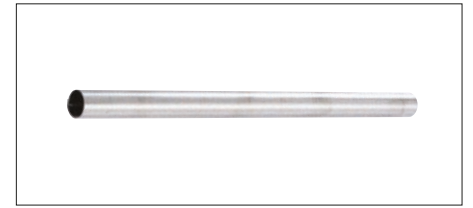

**12x200 mm**  
**50CI12X20**  
12 pcs



**Ø30x120 mm**  
**50CO30X12**  
12 pcs



**Ø35x140 mm**  
**50CO35X14**  
12 pcs

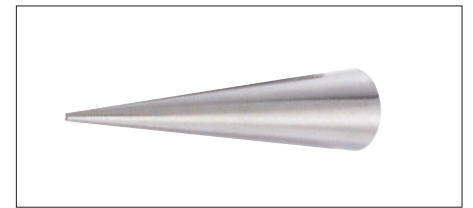

**Ø40x160 mm**  
**50CO40X16**  
12 pcs



**Ø30x120 mm**  
**CANNOLO**  
10 pcs

Stampi in plastica speciale per la  
produzione di cannoli.  
Special plastic mould to make  
cannoli.



## SEGNAPORZIONI - CAKE MARKERS

Porzionatori per torte utilizzabili in entrambi i lati.  
Double faced cake portion markers.

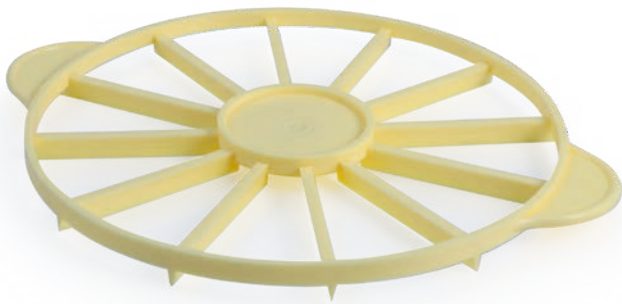

**Segnaporzioni Ø 25 cm in plastica per torte**  
Plastic cake markers Ø 25 cm

**8-12** portions

**PPT 8/12**

**12-16** portions

**PPT 12/16**

**14-16** portions

**PPT 14/16**

**12-18** portions

**PPT 12/18**

**14-18** portions

**PPT 14/18**

**12** portions

**PPT 12**



**Segnaporzioni Ø 33 cm in acciaio per torte**  
St. Steel Cake markers Ø 33 cm

**8** portions

**PPT8X**

**10** portions

**PPT10X**

**12** portions

**PPT12X**

**14** portions

**PPT14X**

**16** portions

**PPT16X**

**18** portions

**PPT18X**



**Griglia Tagliapasta per Crostate**  
Cutter for Tarts

Griglia per il taglio regolare della pasta in modo rapido e semplice.

Grid for regular cutting of dough in a quick and easy way.

**Ø30 cm**

**DECOR 30**

## LIRA - CAKE SLICER



**Lira per pan di spagna**  
Sponge cake slicer

**CS3**

460 mm

3 lame altezza variabile: da 10 a 90 mm.

3 variable height blades: from 10 until 90 mm.

**CSL**

lama di ricambio - spare blade

# MICROPAPER

*Let your creations breathe*



Watch the  
VIDEO

# LA PRIMA CARTA FORNO MICROFORATA THE FIRST MICRO-PERFORATED BAKING PAPER



sviluppata da un'idea di  
*developed from an idea of*



## **Qualità superiore in minor tempo**

Grazie alla presenza della microforatura, durante la cottura il vapore acqueo fuoriesce più velocemente. Questo garantisce un miglior passaggio dell'aria, che raffredda anche i prodotti più velocemente rispetto alla carta forno tradizionale.

## **Superior quality in less time**

Thanks to the micro-perforation, steam escapes faster during baking. This ensures a better airflow, which also cools the products faster than with conventional baking paper.

con Micropaper  
with Micropaper



con carta forno tradizionale  
with traditional baking paper



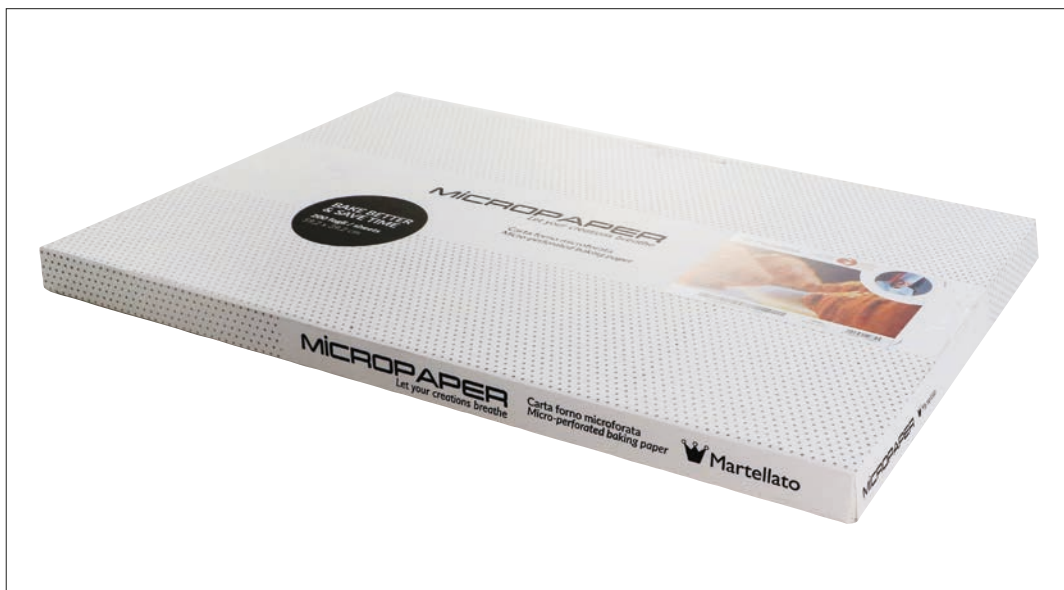

## MICROPAPER

Carta forno microforata - Micro-perforated baking paper

59,2x39,2 CM

**51MP6040**

pack 200 fogli/sheets

**RISPARMIO DI  
TEMPO & ENERGIA**

**ENERGY  
& TIME SAVING**

circa  
approx

**8-10%**



- 1.** MIGLIORE COTTURA  
BETTER BAKING
- 2.** RAFFREDDAMENTO PIÙ VELOCE  
FASTER CHILLING
- 3.** FLUSSO D'ARIA UNIFORME  
UNIFORM AIRFLOW
- 4.** RISPARMIO DI ENERGIA  
ENERGY SAVING
- 5.** COTTURA PIÙ RAPIDA  
FASTER BAKING

## IDEALE PER LA COTTURA DI

bignè • pasta frolla • biscotti • pasta sfoglia • paste lievitate • paste lievitate sfogliate • pasta brisée •  
pane • pizza • focaccia • fonsage tart • cottura crumble e streusel

## IDEAL FOR BAKING

cream puff • shortcrust pastry • biscuits • puff pastry • leavened doughs • leavened puff pastries •  
brisée pastry • bread • pizza • focaccia bread • fonsage tart • crumble and streusel baking



## CARTA FORNO TRADIZIONALE TRADITIONAL BAKING PAPER

**Carta da Forno Professionale** antiaderente e resistente  
alle alte temperature - Bisiliconata.  
Adatta per forno tradizionale e microonde - Multiuso.

**Professional Baking Paper** non-stick and high  
temperatures resistant - silicone on both sides.  
Suitable for traditional and microwave oven - Multiuse.

**60x40 CM**  
**51CF6040**  
500 fogli - sheets



# SET TAGLIA PASTA - CUTTERS KIT

Set tagliapasta in acciaio inox proposti in kit multi misura.  
Stainless steel cutters set offered in multi size kits.



**CUT5L7**

**7 pcs**  
65 - 57 - 50 - 45 - 40  
35 - 27 mm

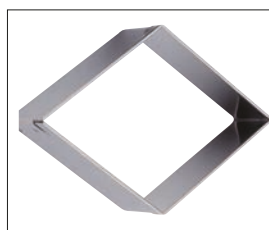

**CUT6L7**

**7 pcs**  
90x60 - 80x50 - 70x45  
- 60x40 - 50x30 - 40x25  
30x20 mm



**CUT22L7**

**7 pcs**  
65x50 - 60x45 - 55x40  
- 50x35 47x32 - 43x28  
37x25 mm

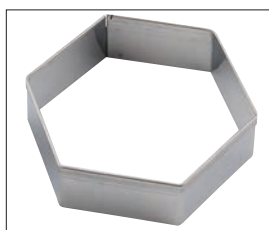

**CUT3L7**

**7 pcs**  
75 - 67 - 63 - 57 - 52  
47 - 42 mm



**CUT28L7**

**7 pcs**  
100x50 - 90x45 - 85x43  
75x40 - 70x35 - 60x30  
55x25 mm



**CUT8L7**

**7 pcs**  
90x60 - 80x50 - 70x45  
65x40 - 55x33 - 45x25  
35x20 mm



**CUT15L7**

**7 pcs**  
86x45 - 76x38 - 68x33  
61x30 55x25 - 49x21  
42x17 mm



**CUT16L7**

**7 pcs**  
80 - 75 - 67 - 60 - 50  
40 - 33 mm



**CUT26L7**

**7 pcs**  
90 - 80 - 70 - 55 - 40  
35 - 30 mm



**CUT18L7**

**7 pcs**  
90x65 - 80x60 - 70x50  
55x40 45x30 - 33x23  
25x18 mm



**CUT31L7**

**7 pcs**  
90 - 80 - 70 - 60 - 50  
40 - 30 mm

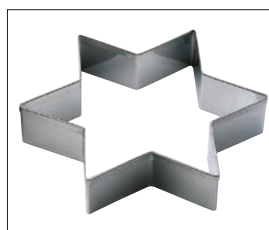

**CUT10L9**

**9 pcs**  
37 - 51 - 66 - 82 - 96  
110 - 125 - 137 - 150 mm



**CUT12L7**

**7 pcs**  
90 - 80 - 65 - 53 - 42  
55 - 30 mm



**CUT20L7**

**7 pcs**  
90 - 75 - 70 - 55 - 45  
40 - 25 mm

## OVALI - OVAL



LISCI - SMOOTH

**CUT2L7 - 7 pcs**

85x70-75x65-65x55-55x45 45x35-35x25-23x18 mm

**CUT2L9 - 9 pcs**

27x34-33x46-42x57-51x68-62x78-71x87-82x97-92x107-102x117 mm

## TONDI - ROUND



LISCI - SMOOTH

**CUT1L7 - 7 pcs**

30-40-50-60-70-80-90 mm

**CUT1L9 - 9 pcs**

30-40-50-60-70-80-90-100-110 mm

**CUT1L12 - 12 pcs**

30-40-50-60-70-80-90-100-110-120-130-140 mm

**CUT1L16 - 16 pcs**

20-30-40-50-60-70-75-80-85-90-95-100-110-120-125-140 mm

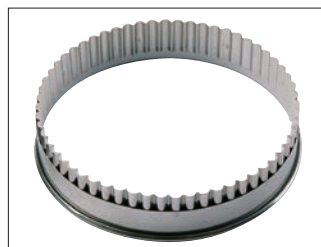

ONDULATI - WAVY

**CUT1F9 - 9 pcs**

30-40-50-60-70-80-90-100-110 mm

**CUT1F12 - 12 pcs**

30-40-50-60-70-80-90-100-110-120-130-140 mm

## CUORI - HEART



LISCI - SMOOTH

**CUT7L7 - 7 pcs**

35-40-45-55-65-75-85 mm

**CUT7L9 - 9 pcs**

36-43-52-60-70-80-90-100-110 mm

**CUT7L12 - 12 pcs**

36-43-52-60-70-80-90-100-110-120-130-140 mm



ONDULATI - WAVY

**CUT7F9 - 9 pcs**

60-70-80-90-100-110-120-130-140 mm

Taglia pasta in acciaio inox, con manico. - Stainless steel cutter, with handle.



LISCI - SMOOTH

**CUT1LM12**

Ø 120 x h20 mm

**CUT1LM14**

Ø 140 x h20 mm



ONDULATI - WAVY

**CUT1FM12**

Ø 120 x h20 mm

**CUT1FM14**

Ø 140 x h20 mm

## MINI TAGLIA PASTA - MINI CUTTERS



Set tagliapasta - Praline cutters set

**PRA 9**

Tagliapasta inox per praline di marzapane

St. Steel marzipan pralines cutters set

h 50 mm



35x20



30x19



40x23



25x25



35x35



35x25



40x27



40x23



Ø28

# GRIGLIE TAGLIAPASTA PLASTIC CUTTER GRIDS

Placca in plastica per la produzione di soggetti tematici di pasta frolla, sfoglia ed altri impasti. Ideale per la preparazione di biscetteria dolce e salata.

Plastic grid for cutting shortcrust pastry, puff pastry and other doughs. Ideal for preparing sweet and savory biscuits. Misure-Size: 60x40cm

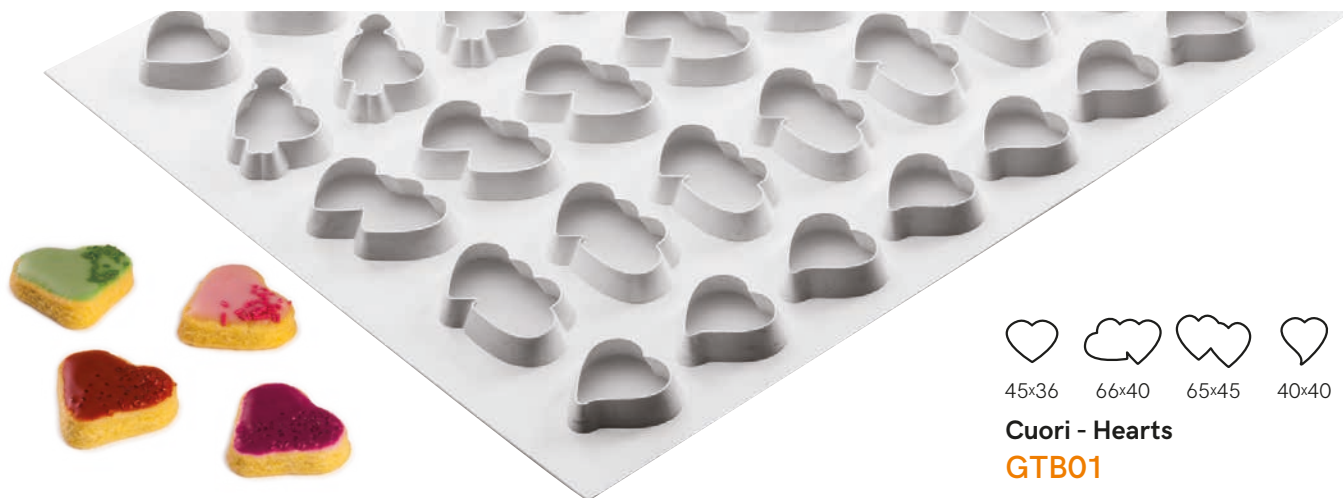

45x36 66x40 65x45 40x40 45x38

**Cuori - Hearts**  
**GTB01**



73x70 85x45 66x55 45x90 70x46

**Halloween**  
**GTB02**



54x43 67x45 50x42 64x37 50x46 58x67 45x48

**Fiori Foglie - Flowers Leaves**  
**GTB05**



40x40 mm - 35pcs

**Croce Festonata - Wavy Cross**  
**GTB18**



60x42 65x41 73x50 66x53

**Anim. domestici - Pets**  
**GTB06**

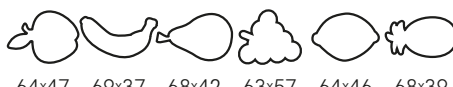

64x47 69x37 68x42 63x57 64x46 68x39

**Frutta - Fruit**  
**GTB08**

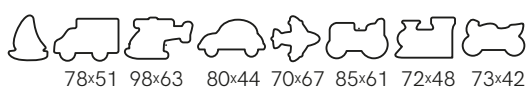

78x51 98x63 80x44 70x67 85x61 72x48 73x42

**Trasporti - Transport**  
**GTB10**



42x38 mm - 35pcs

**Stella - Star**  
**GTB17**



Ø39 mm - 40pcs

**Tondo festonato - Wavy round**  
**GTB15**



39x36 mm - 40pcs

**Cuore - Heart**  
**GTB19**



**Dolce San Martino**

**SMA320**

stampo - mould 380x400 mm  
soggetto - subject 300x340 mm

**SMA260**

stampo - mould 295x330 mm  
soggetto - subject 245x270 mm

**SMA180**

stampo - mould 230x260 mm  
soggetto - subject 180x200 mm

**SMA110**

stampo - mould 170x190 mm  
soggetto - subject 110x125 mm



**Biscotti San Martino**

**GTB13**

stampo - mould 578x390 mm  
soggetto - subject 77x100 mm  
15 pcs

# FLACONI - BOTTLES



**Flacone per bagna e sciroppo**  
**Syrup soaker bottle**

**50FL00** cap. 1 lt  
100x56 h275 mm

**50FL00C** cap. 1 lt  
con tappo e copritappo/with cap  
100x56 h275 mm



**Flacone per bagna e sciroppo**  
**Syrup soaker bottle**

**FLACONE** cap. 1 lt  
70x70 h270 mm



**Porta Flacone - Bottles holder**

**PORTFLACONE**

250x110 h 80 mm

Cap. 3 x FLACONE

Flaconi non inclusi/Bottles not included



**Flacone per bagna e sciroppo**  
**Syrup soaker bottle**

**FLAN1** cap. 1 lt  
Ø85 h 250 mm

**50FLAN2** cap. 0,5 lt



**Flacone nebulizzatore**  
**Spraying bottle**

**FLACONE2** cap. 1 lt  
70x70 h300 mm

**50FLAN2T** cap. 0,5 lt



**Flacone dosatore - tappo con beccuccio**  
**Dosage bottle - cap and nozzle**

**BO1000N** cap. 1 lt  
Ø79 h283 mm

**BO500N** cap. 0,5 lt  
Ø60 h253 mm

**BO250N** cap. 0,25 lt  
Ø50 h194 mm

**BO100N** cap. 0,1 lt  
Ø40 h138 mm

## DIME - TEMPLATES

Dime di taglio in plastica trasparente per il taglio in strisce regolari di pastafrolla, cioccolato e biscuit.  
Transparent plastic grids for cutting regular strips of shortcrust pastry, chocolate and biscuit.

### 50GD0015

Griglia speciale per tagli da 1,5 cm.  
Special grid to cut 1,5 cm.

### 50GD0018

Griglia speciale per tagli da 1,8 cm.  
Special grid to cut 1,8 cm.

### 50GD0022

Griglia speciale per tagli da 2,2 cm.  
Special grid to cut 2,2 cm.

### 50GD0027

Griglia speciale per tagli da 2,7 cm.  
Special grid to cut 2,7 cm.

### 50GD0037

Griglia speciale per tagli da 3,7 cm.  
Special grid to cut 3,7 cm.

### 50GD2040

Griglia speciale per tagli da 2 e 4 cm.  
Special grid to cut 2 and 4 cm.

### 50GD3060

Griglia speciale per tagli da 3 e 6 cm.  
Special grid to cut 3 and 6 cm.

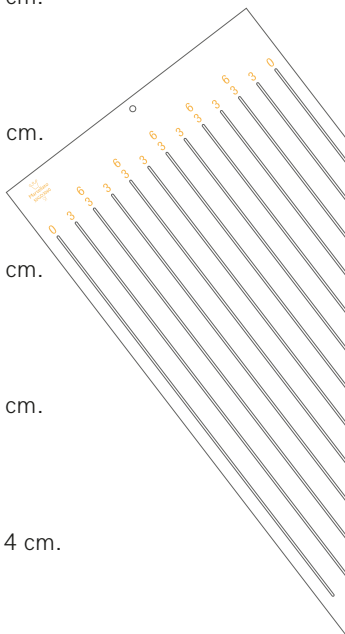

## Righelli trasparenti in plastica - Plastic transparent rulers

### RIGA64

5 Divisioni da 12 cm e 7 divisioni da 8 cm.  
Five 12 cm divisions and seven 8cm divisions.

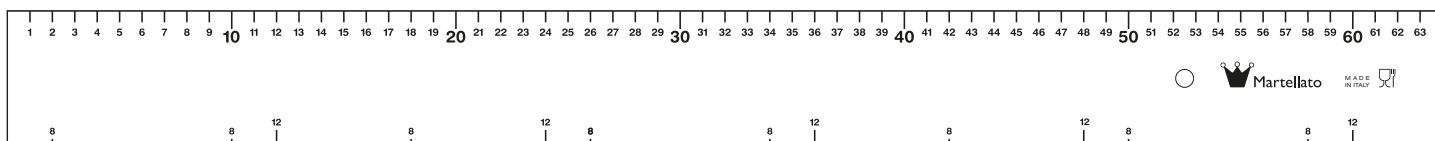

## TAGLIERI - CUTTING BOARD

### Taglieri Cutting board

Piano di lavoro in plastica  
Plastic worktop

**TAG5**  
50x30 h3 cm

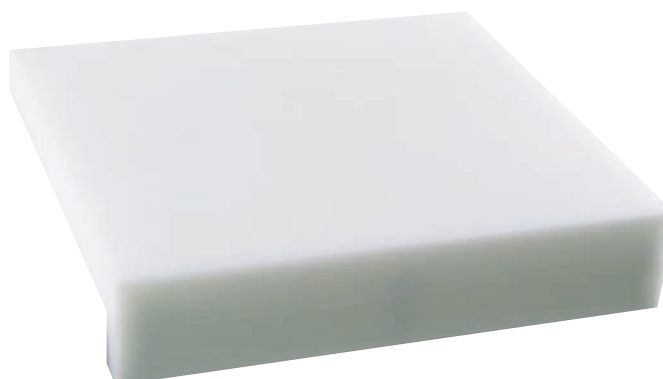

# TEGLIE FORNO - BAKING TRAYS

Servizio teflonatura su richiesta  
On demand tefloning service



## TEGLIE ALLUMINIO ALUMINIUM TRAYS

### 53TA60404

2cm - 60x40 cm

Teglia in **alluminio** con **4 bordi**, spessore 1,5 mm  
Aluminium baking tray with **4 edges**, 1,5 mm thick

### 53TA60402

2cm - 60x40 cm

Teglia in **alluminio** con **2 bordi**, spessore 1,5 mm  
Aluminium baking tray with **2 edges**, 1,5 mm thick



## TEGLIE FORATE ALLUMINIO PERFORATED ALUMINIUM TRAYS

### 53TAF60404

2cm - 60x40 cm

Teglia forata in **alluminio** con **4 bordi**, spessore 1,5 mm  
Flat **perforated aluminium** baking tray with **4 edges**, 1,5 mm thick

### 53TAF40304

2cm - 40x30 cm

Teglia forata in **alluminio** con **4 bordi**, spessore 1,5 mm  
Flat **perforated aluminium** baking tray with **4 edges**, 1,5 mm thick

### 53TAF40302

2cm - 40x30 cm

Teglia forata in **alluminio** con **2 bordi**, spessore 1,5 mm  
Flat **perforated aluminium** baking tray with **4 edges**, 1,5 mm thick



## TEGLIE ALLUMINATE ALUMINIZED TRAYS

### 53TL60404

2cm - 60x40 cm

Teglia **alluminata** con **4 bordi**, spessore 0,8 mm  
Made of aluminized sheet with **4 edges**, 0,8 mm thick

### 53TL60402

2cm - 60x40 cm

Teglia **alluminata** con **2 bordi**, spessore 0,8 mm  
Made of aluminized sheet with **2 edges**, 0,8 mm thick

# TAPPETI COTTURA - BAKING MATS

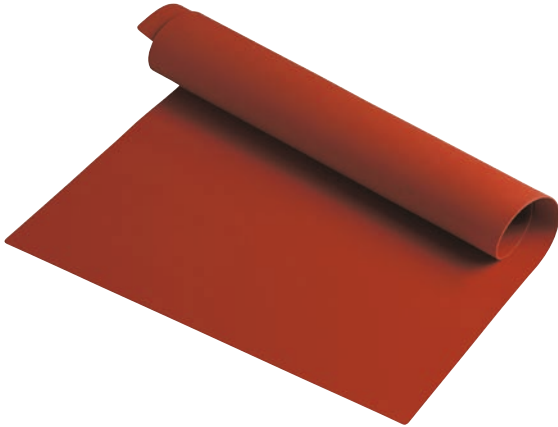

Tappeti antiaderenti in silicone per cottura e surgelazione di qualsiasi prodotto alimentare.

Non-stick silicon mats for baking and freezing every kind of food.

**39,5x59,5 CM**  
**SILICOPAT1/R**

**30X40 CM**  
**SILICOPAT7/R**

**27x42 CM**  
**SILICOPAT5/R**

**31x51 CM**  
**SILICOPAT2/R**

**36x43 CM**  
**SILICOPAT6/R**



Tappeti antiaderenti in silicone con fibra di vetro per cottura e surgelazione di qualsiasi prodotto alimentare.

**Ideali per la lavorazione dello zucchero.**

Non-stick silicon mats with glass fibres for baking and freezing every kind of food. **Ideal to work with sugar.**

**59x39 CM**  
**SILICOPAT1/B**

**31x51 CM**  
**SILICOPAT2/B**

**62X42 CM**  
**SILICOPAT3/B**

**79x59 CM**  
**SILICOPAT4/B**



Tappetino antiaderente in PTFE antiaderente.  
Non stick PTFE mat.  
Pack 5 pcs.

**59X39 CM**  
**TEFLONPAT5**



Tappeti silicone microforato con fibra di vetro.  
Silicone mats perforated with glass fibres.

**38,5x58,5 CM**  
**MICROMAT60**

**38,5x28,5 CM**  
**MICROMAT30**

## CARAFFE - CARAFES



**Caraffa graduata MAXI in plastica di alta qualità.  
MAXI graduated carafe made of high quality plastic.**

Impugnatura chiusa rinforzata, plastica translucida,  
scala graduata in rilievo.  
Resistente agli urti anche alle basse temperature.

Reinforced closed handle, translucent plastic,  
graduated scale in relief.  
Impact resistant even at low temperatures.



**Caraffa con coperchio  
Carafe with lid**

**CFTRA6C** - 6000 ML  
coperchio paraschizzi apribile  
openable splash protection lid

**Caraffa  
Carafe**

**CFTRA6** - 6000 ML



**Caraffe graduate plastica trasparente  
Transparent plastic measuring cups**

Caraffa graduata in plastica impugnatura aperta.  
Plastica trasparente - impilabili.

Graduated plastic carafe with open handle.  
Transparent plastic - stackable.

**500 ml**

**CFTRA1**

**1000 ml**

**CFTRA2**

**2000 ml**

**CFTRA3**

**3000 ml**

**CFTRA4**

## SESSOLE - FLOUR SCOOPS

Pratiche sessole in plastica con base piatta, per conferire stabilità anche se appoggiate, adatte anche a liquidi.  
Practical plastic bailers with a flat base, in order to provide stability even if laid, suitable for liquids as well.



**125 ml**

**SES 100**

Size: 185x65 mm  
Spoon: 110x65 mm

**250 ml**

**SES 250**

Size: 250x90 mm  
Spoon: 150x90 mm

**512 ml**

**SES 500**

Size: 310x117 mm  
Spoon: 190x117 mm

**857 ml**

**SES 800**

Size: 345x145 mm  
Spoon: 230x145 mm

**1520 ml**

**SES 1500**

Size: 400x175 mm  
Spoon: 275x175 mm

## CIOTOLE - BOWLS

**Ciotola in policarbonato trasparente**  
**Transparent polycarbonate bowls**



**0,4 L**

**52BO13PC**

Ø 13 cm

**1 L**

**52BO17PC**

Ø 17 cm

**2,5 L**

**52BO23PC**

Ø 23 cm

**4 L**

**52BO28PC**

Ø 28 cm

**8 L**

**52BO32PC**

Ø 32 cm

**10 L**

**52BO38PC**

Ø 38 cm

**Ciotola in polipropilene bianco**  
**White polypropylene bowls**



**0,4 L**

**52BO13PP**

Ø 13 cm

**1 L**

**52BO17PP**

Ø 17 cm

**2,5 L**

**52BO23PP**

Ø 23 cm

**4 L**

**52BO28PP**

Ø 28 cm

**8 L**

**52BO32PP**

Ø 32 cm

**10 L**

**52BO38PP**

Ø 38 cm

# STAMPI PANE - BREAD MOULDS

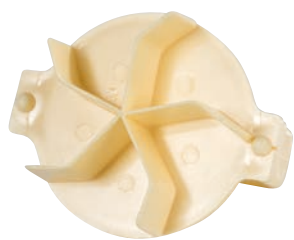

Stampo per pane kaiser  
Kaiser bread mould

**STPTA 6**

Ø8cm



Stampo per pane kaiser  
Kaiser bread mould

**STPTA 7**

Ø8cm

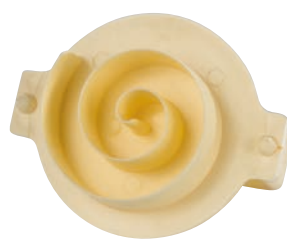

Stampo per pane girella  
Girella bread mould

**STPTA 8**

Ø8cm



Stampo per pane zucca  
Pumpkin bread mould

**STPZ**

Ø8cm



Stampo pane tartaruga quadrato  
Square turtle bread mould

**STPTA 1**

14x10cm



Stampo pane tartaruga esagonale  
Hexagonal turtle bread mould

**STPTA 2**

14x11cm



Stampo pane margherita  
Marguerite bread mould

**STPTA 5**

Ø12,5cm



Stampo pane sole  
Sun bread mould

**STPTA 3**

Ø12,5cm



Marcatore girevole per pane kaiser  
Kaiser bread revolving marker

**STPK**

L 200 - Ø6cm

# TELO COPRI IMPASTO DOUGH PROOFING SHEET

Ideale per proteggere gli impasti durante la lievitazione conservando il giusto livello di umidità, riparando da agenti esterni ed aria. Il telo è utile per coprire i prodotti da forno durante il raffreddamento in modo da trattenere gli aromi che si sprigionano subito dopo la cottura. Realizzato in **trasparente polietilene alimentare**, destinato ad uso professionale, garantisce la massima igiene, praticità d'uso e durata nel tempo.

Ideal for protecting doughs during leavening and maintaining the right level of humidity, protecting from external agents and air. The sheet is also useful for covering baked goods during cooling in order to retain the aromas that are released immediately after cooking. Made of **transparent food-grade polyethylene**, for professional use, it guarantees maximum hygiene, practical use and durability.

55TP6080

60X80CM

PACK 50 pcs - 70 My



# CESTINI PANE - BREAD BASKET

Cestini per lievitazione  
Leavening bread baskets



Cap. gr	Size cm	Code
1500	Ø25	BASKET 205
1000	Ø21,5	BASKET 206
500	Ø18	BASKET 207
250	Ø13	BASKET 208

Cap. gr	Size cm	Code
1500	40x14	BASKET 105
1000	35x13	BASKET 106
500	27x12	BASKET 107

Cap. gr	Size cm	Code
1000	29x18	BASKET 102
500	22x14	BASKET 103
750	24x14	BASKET 108

# TAGLIERINI - BREAD CUTTERS

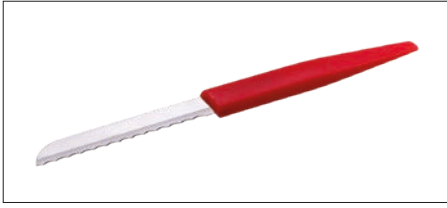

Lama ondulata - Fluted blade  
INOX

**CUTTER 8**

9cm



Coltellino doppia lama ondulata  
Cutter with double fluted blade

**CUTTER 12**

8cm



Lama ondulata - Fluted blade  
INOX

**50COL51**

8cm



Lama liscia - Plain blade  
INOX

**CUTTER 7**

9cm



Lama liscia - Plain blade  
INOX

**50COL50**

7cm



Lama segna pane  
Marking bread blade

**CUTTER 15**



Coltellino plastica lama girevole  
Plastic cutter with rotating blade

**CUTTER 4**



Coltellino plastica lama fissa  
Plastic cutter with fixed blade

**CUTTER 1**



Cutter baguette con manico plastica  
Plastic cutter for bread

**CUTTER13**

kit 2 pcs

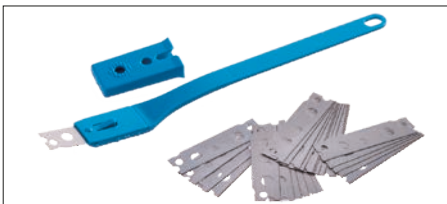

Coltellino plastica lama fissa  
Plastic cutter with fixed blade

**CUTTER5**

1 Cutter + 25 lame/blades

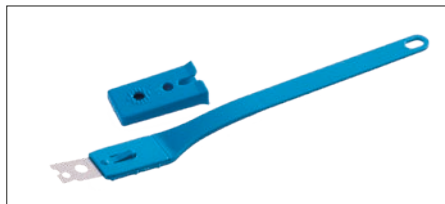

Coltellino plastica lama fissa  
Plastic cutter with fixed blade

**CUTTER5/A**

1 Cutter

## SPAZZOLE - BRUSHES



**SPZ SE**  
400x40 mm  
Temp. MAX 90° C

con setole naturali.  
with natural bristles.



**SPZ PL1**  
210x65 mm  
Temp. MAX 130° C

con setole in poliestere.  
with polyester bristles.



Spazzola inox - Inox brush

**SPZ INOX**  
145x55 mm

con setole in acciaio inox.  
with stainless steel bristles.

## CAPPELLI IN CARTA - PAPER HATS



**h 250 mm**  
**CAP2B**  
10 pcs



**h 200 mm**  
**CAP 3**  
10 pcs Regolabile - Adjustable

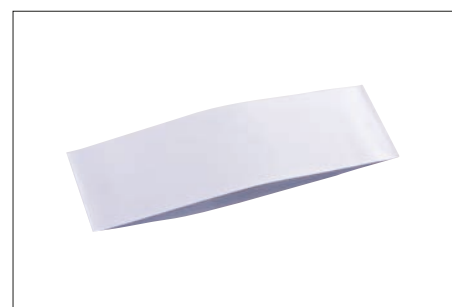

**280x h85mm**  
**CAP 4**  
25 pcs

# GUANTI - GLOVES



## Manopole in pelle - Leather mitten

**GL1**

380x150 mm

Resistenti fino ad una temperatura di ca. 250°C  
Realizzate in pelle morbida e rivestimento interno di gomma piuma.

Heat resistant up to a temperature of approx. 250 ° C  
Made of soft leather and foam inner lining

CE marking: II CAT. EN 388:2016 EN 407:2004



## Manopole in pelle polso lungo - Long leather mitten

**GL2**

450x150 mm

Resistenti fino ad una temperatura di ca. 250°C  
Ideali per la protezione della mano e dell'avanbraccio.  
Realizzate in pelle morbida e rivestimento interno di cotone.

Heat resistant up to a temperature of approx. 250°C  
Ideal for arm and hand protection.  
Made of soft leather and inner lining of cotton.

CE marking: II CAT. EN 388:2016 EN 407:2004



## Guanti in pelle a tre dita - Three-fingers leather oven gloves

**GL3**

340x140 mm

Resistenti fino ad una temperatura di ca. 250°C  
Realizzati in pelle morbida e rivestimento interno di cotone.

Heat resistant up to a temperature of approx. 250 ° C  
Made of soft leather and inner lining of cotton.

CE marking: II CAT. EN 388:2016 EN 407:2004



## Manopole in cotone Short cotton mitten

**GL10**

100% cotone - cotton - 27x15cm



## Manopole lunghe in cotone Long cotton mitten

**GL11**

100% cotone - cotton - 34x15cm



## Presine per forno in pelle Oven leather pot holder

**GL25PRE**

25x35cm

**GL18PRE**

18x25cm

# SEGNAPREZZI - PRICE CARDS



**SEG001N**  
70x40mm - 15 pcs



**SEG002N**  
60x80mm - 25 pcs



**SEG008N**  
60x90mm - 25 pcs

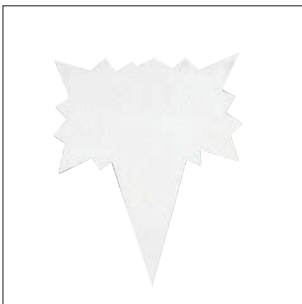

**SEG015N**  
60x50mm - 50 pcs



**SEG005N**  
55x80mm - 50 pcs



**SEG006N**  
60x80mm - 40 pcs



**SEG024N**  
55x92mm - 25 pcs

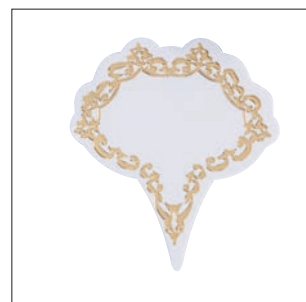

**SEG004N**  
35x40mm - 30 pcs



**SEG027N**  
65x62mm - 15 pcs

# CAKE BOARD

SPESSORE  
THICKNESS  
**8**  
MM

## TAVOLE MULTIFUNZIONE

per lo spostamento e stoccaggio di torte ed altri prodotti. Realizzate in materiale plastico di alta qualità e resistenza, non assorbono odori, né umidità.

## MULTI-PURPOSE BOARDS

for moving and store cakes and other products. Made of a high quality and resistant plastic material, they absorb neither odor nor moisture.



Realizzati in materiale parzialmente proveniente da plastica riciclata.  
Made of material partially from recycled plastic.



Disponibili in diverse misure e forme, per adattarsi alle molteplici esigenze. Disponibili anche con piedini a sfera Ø 25 mm. **Altre misure forme realizzabili su richiesta.**

Available in many sizes and shapes, suitable for different needs. Available with or without plastic feet Ø 25 mm. **Other shapes and sizes on request.**

### Rotonda - Round

Misura Size cm	Piedini Feet	Codice Code
Ø 40	4	TAV D. 40 C/P
Ø 40	no	TAV D. 40 PIA
Ø 50	5	TAV D. 50 C/P
Ø 50	no	TAV D. 50 PIA
Ø 60	5	TAV D. 60 C/P
Ø 60	no	TAV D. 60 PIA
Ø 70	9	TAV D. 70 C/P
Ø 70	no	TAV D. 70 PIA
Ø 80	9	TAV D. 80 C/P
Ø 80	no	TAV D. 80 PIA
Ø 90	9	TAV D. 90 C/P
Ø 90	no	TAV D. 90 PIA
Ø 100	13	TAV D. 100 C/P
Ø 100	no	TAV D. 100 PIA

### Rettangolare - Rectangular

Misura Size cm	Piedini Feet	Codice Code
40x60	5	TAV 40X60 C/P
59x39	no	TAV 59X39
40x60	no	TAV 60X40
50x60	5	TAV 50X60 C/P
50x60	no	TAV 50X60 PIA
60x70	9	TAV 60X70 C/P
60x70	no	TAV 60X70 PIA
60x80	12	TAV 60X80 C/P
60x80	no	TAV 60X80 PIA

### Quadrata - Square

Misura Size cm	Piedini Feet	Codice Code
50x50	4	TAV 50X50 C/P
50x50	no	TAV 50X50 PIA
60x60	5	TAV 60X60 C/P
60x60	no	TAV 60X60 PIA
70x70	9	TAV 70X70 C/P
70x70	no	TAV 70X70 PIA

piedino - plastic feet Ø 25 mm

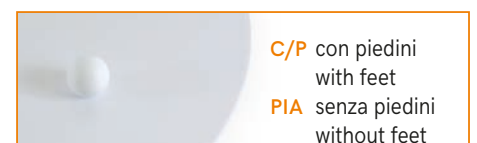

**C/P** con piedini  
with feet  
**PIA** senza piedini  
without feet

SOTTOTORTA ROTONDI IN PLASTICA RIGIDA  
HARD PLASTIC ROUND CAKE BOARDS

SPESSORE  
THICKNESS  
**3**  
MM

**Kit completo - Complete kit**

**SET DISK**

kit 8 pcs (PST)

Ø 20 - Ø 22 - Ø 24 - Ø 26 - Ø 28 - Ø 30 - Ø 32 - Ø 34



**Misure singole**

**Single size**

kit 3 pcs (PST)

Size cm	Codice Code
Ø 20	50DI20
Ø 22	50DI22
Ø 24	50DI24
Ø 26	50DI26
Ø 28	50DI28
Ø 30	50DI30
Ø 32	50DI32
Ø 34	50DI34

SOTTOTORTA IN PLASTICA ALVEOLATA  
HONEYCOMB PLASTIC CAKE BOARDS

20 pcs

SPESSORE  
THICKNESS  
**2**  
MM



**Rotondi - Round**

Size cm	Codice Code	Size cm	Codice Code
Ø 16	50ST16	Ø 26	50ST26
Ø 18	50ST18	Ø 28	50ST28
Ø 20	50ST20	Ø 30	50ST30
Ø 22	50ST22	Ø 32	50ST32
Ø 24	50ST24	Ø 40	50ST40

**Accessori per copertura carrelli**

**Trolleys cover accessories**



**Copertura monosuo per carrelli**  
**Disposable trolley cover**

**50CP01**

GN 2/1 60x40 h 180 cm  
roll 200 pcs - 20 micron

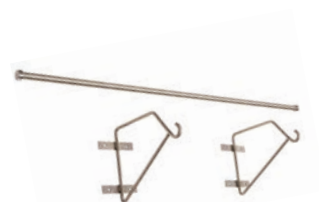

**Staffa inox da muro porta rotolo**  
**Stainless steel wall bracket for roll holder**

**50ST01 - porta rotolo - roll holder 50CP01**



# DECORATION



# SUGAR LAMP

Lampada per Zucchero

Ideata per la lavorazione dello zucchero.  
 Realizzata in metallo verniciato e acciaio spazzolato.  
 Regolazione del corpo lampada in altezza ed in inclinazione.  
 Controllo della potenza su 2 livelli: 600- 1200W.  
 Piano di lavoro: 625 x 450 mm - completa di cablaggio elettrico.

Designed for sugar processing.  
 Made in varnished metal and brushed steel.  
 Height and tilt adjustment of the lamp body.  
 2-level power control: 600- 1200W.  
 Work surface: 625 x 450 mm - complete with electric cable.

Lampada - Lamp  
**LAMP01**

Smontaggio rapido  
 Quick disassembly

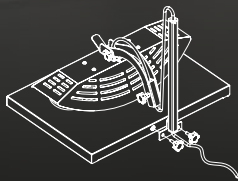

Inclinazione di 40°  
 del corpo lampada verso l'operatore

40° inclination of the lamp towards the operator

Base perfettamente planare

Perfectly planar base

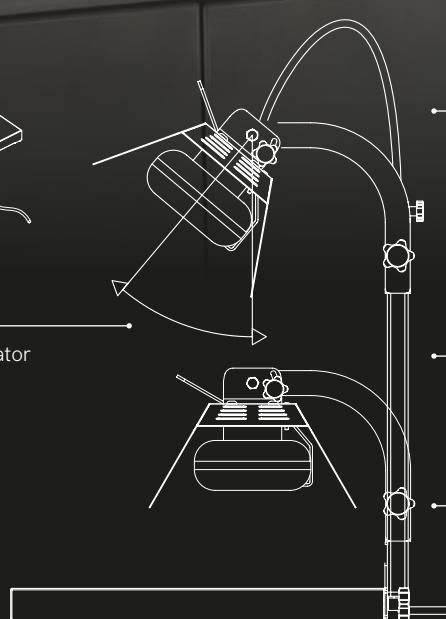

Cavo di alimentazione posizionato  
 all'interno per una maggiore sicurezza

The power cable runs inside the pole  
 for improved safety

Scorrimento verticale

Vertical scrolling

Maniglia per regolare l'inclinazione della lampada

Handle to adjust the lamp inclination

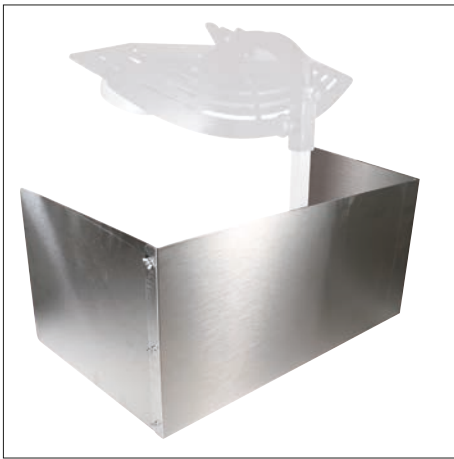

**Paratia antivento acciaio inox**  
**Stainless steel shelter**

**LAMPLEX**

Dimensioni/dimensions 65x32 h 40 cm



**Caramellometro**  
**Caramellometer**

**MTE** - h 30cm  
da +80°C a +200°C  
from +80°C to +200°C



**Supporto caramellometro**  
**Caramellometer holder**

**MRTE** - h13,7cm



**Guanti in lattice - Latex gloves**

**GL 7** - taglia/size **7 - 7,5**

**GL 8** - taglia/size **8 - 8,5**

**GL 9** - taglia/size **9 - 9,5**



**Pompetta - Sugar pump**

**POMP**

## CANNELLI - TORCH

Cannelli multifunzionali per pasticceria, gastronomia e cucina. Ideali per caramellare zucchero e meringhe, gratinare, scaldare e sciogliere. Fiamma regolabile, pulsante fiamma continua. Impugnatura antiscivolo, facilmente ricaricabile. Gas non incluso.

Multifunctional kitchen torches for pastry, gastronomy and cooking. Ideal for caramelising sugar and meringues, gratinating, heating and melting. Adjustable flame, continuous flame button. Non-slip grip, easily rechargeable. Gas not included.



**CANNELLO PRO**

Dimensioni/dimensions 154x74x198 mm  
Temperature 1300°C / 2400°F  
Volume 140 ml butano/butane  
Autonomia gas serbatoio pieno/burning  
time full tank 60 min



**CANNELLOBIG**

Cartuccia usa e getta, corpo in plastica  
Disposable cartridge torch, plastic body  
Ugello/nozzle 0,28 mm - Potenza/power  
1.90 kW

# CAKE DESIGN

*Italian*<sup>®</sup>  
Cake Art



## SUGAR MATS

**Tappeti in silicone** ideali per vestire il tuo dolce con un decoro in zucchero di grande effetto.  
**Silicone mats** ideal to dress up your cake with an impressive sugar decoration. Misura - Size: 30x40cm



40-WD001 Decorations: 388x88mm



40-WD002 Decorations: Ø88mm

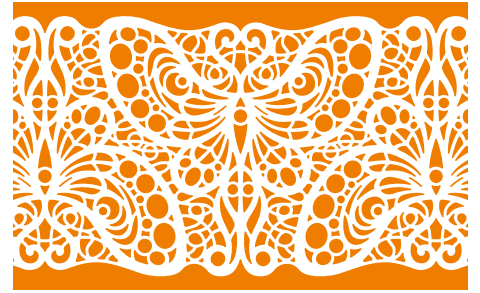

40-WD003 Decorations: 388x86mm



40-WD004 Decorations: Ø79mm

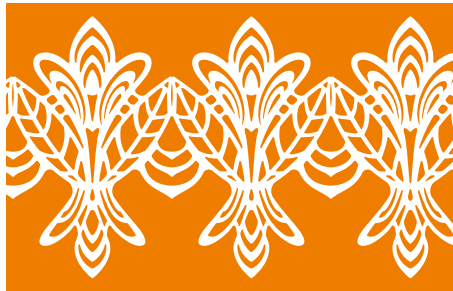

40-WD005 Decorations: 380x86mm



40-WD006 Decorations: 72x72mm

## SUGAR DRESS

Preparato per la creazione di pizzi e decorazioni per torte, pasticcini e cupcake. **Sugar dress** è un sistema facile e veloce per ottenere un decoro raffinato e di grande effetto. È sufficiente aggiungere ai due preparati dell'acqua, mescolare bene il composto e spalmarlo con una spatola nell'apposito tappetino Martellato.

Prepared for the creation of lace and decorations for cakes, pastries and cupcakes. **Sugar dress** is an easy and quick system to obtain a refined and impressive decoration. Simply add waterto the two preparations, mix the mixture well and spread it with a spatula in the special Martellato mat.



SUGAR DRESS

**EFSD001**

**Bianca - White**

Secchiello 500 gr - Bucket 500 gr  
 GLUTEN FREE



# FIORI - FLOWERS



LILIUM

**40-W049S**  
17x48mm - 24x70mm - 32x90mm - 39x110mm



**40-W055**  
**Controstampo - Formers**  
Ø 160 h60mm - Kit 4 pcs



SURFINIA

**40-W193S**  
66x60 - 38x52 mm



**40-W193C**  
**Controstampo - Formers**  
Ø 75 h50mm - Kit 4 pcs



DAHLIA

**40-W206S**  
Ø90mm - Ø65 mm

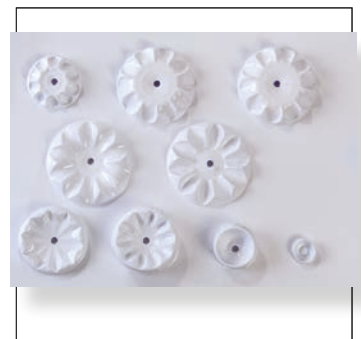

**40-W206C**  
**Controstampo - Formers**  
380x280mm - Kit 5 pcs



TULIP

**40-W194S**  
27x46mm - 66x37mm



**40-W194B**  
**Supporto - Flower formers**  
Ø 100 h90mm - Kit 5 pcs



**40-W194C**  
**Controstampo - Formers**  
380x280mm - Kit 5 pcs



**POINSETTIA** **40-W188S**  
17x32 - 29x52 - 31x62 - 37x60 mm



**IBISCUS** **40-W051S**  
19x48mm - 27x70mm - 35x90mm - 44x110mm



**40-W027**  
**Controstampo - Formers**  
Ø 115 h55mm - Kit 4 pcs



**ROSE** **40-W028**  
32x29mm - 39x34mm - 47x40mm



**ORCHID** **40-W030**  
72x72mm - 96x66mm  
57x31mm



**40-W053**  
**Controstampo - Formers**  
Ø 132 h55mm

# VENATORI - VEINERS

Stampo **venatore** in silicone e **cutter** in plastica per venare petali e foglie.  
**Veiner** silicon mould and plastic **cutter** to veiner petals and leaves.

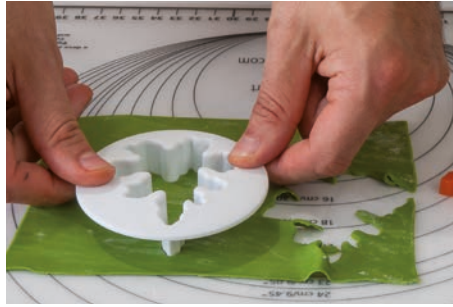

40-WF001 81x55mm



40-WF002 55x46mm



40-WF003 110x97mm



40-WF007 160x69mm



40-WF008 89x31mm



40-WF009 66x39mm

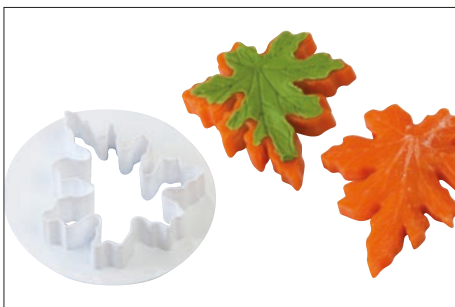

40-WF010 74x69mm



40-WF012 85x34mm  
 solo venatore - only veiner

## Pantografino - Pantograph

40-WA001V

Il kit include:

4 rotelline lisce - 4 coppie di rotelline ondulate  
2 distanziatori da 15 mm - 2 distanziatori da 10 mm  
4 distanziatori da 5 mm

The kit includes:

4 smooth wheels and 4 couples of fluted wheels  
2 spacers 15 mm - 2 spacers 10 mm - 4 spacers 5 mm



## CUTTER LETTERE E NUMERI LETTERS AND NUMBERS CUTTER

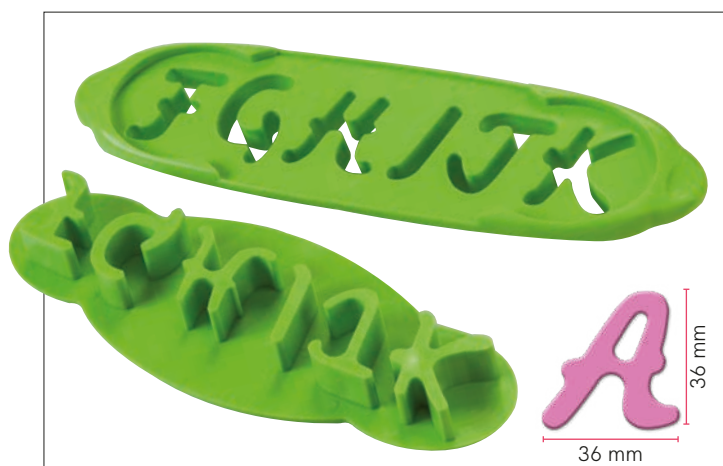

### Cutter Lettere - GRANDI Letter Cutter - BIG

40-WA002

Il kit include: stampi lettere dalla A alla Z, set 5 pz  
The kit includes: letters cutters from A to Z, set of 5 pcs

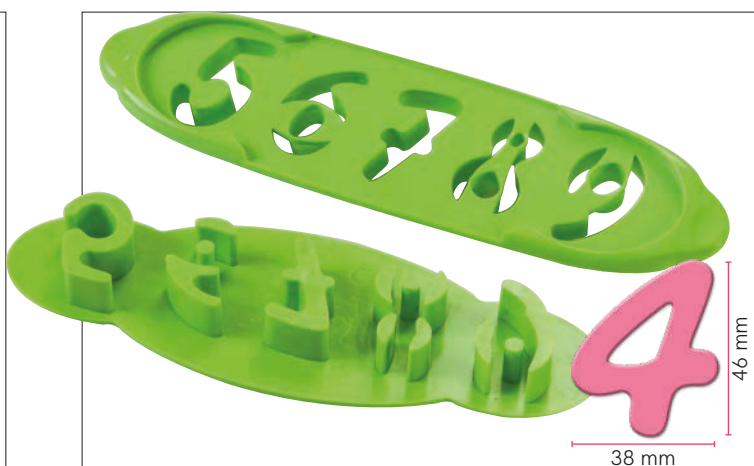

### Cutter Numeri - GRANDI Numbers Cutter - BIG

40-WA003

Il kit include: stampi dallo 0 al 9 set 2 pz  
The kit includes: cutters from 0 to 9, set of 2 pcs



### Cutter Letterine Small Letter Cutter

40-WA008

Il kit include: stampi lettere dalla A alla Z, set 5 pz  
The kit includes: letters cutters from A to Z, set of 5 pcs

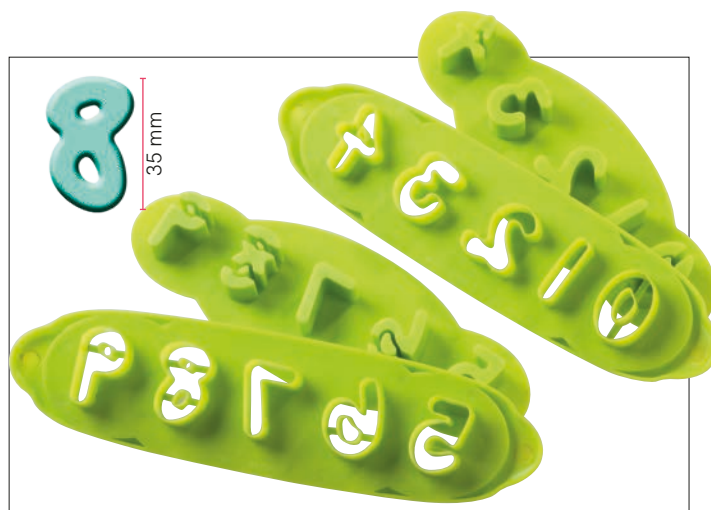

### Cutter Numerini Small Numbers Cutter

40-WA009

Il kit include: stampi dallo 0 al 9 set 2 pz  
The kit includes: cutters from 0 to 9, set of 2 pcs

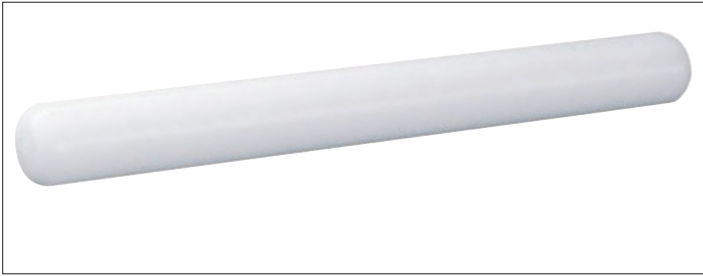

**Mattarelli in teflon - Teflon Rolling pin**

- 40-W021** - Piccolo/Small Ø25mm - 230mm
- 40-W154** - Medio/Medium Ø45mm - 350mm
- 40-W022** - Lungo/Long Ø45mm - 500mm



**Set 8 Anelli - Set 8 Ring**

- 40-W164A**
- Spessore - Thickness  
4-5-6-10mm per/for:  
40-W021 Ø25mm



**Paletta per lisciare - Smoother**

**40-W004**



**Kit 3 rotelline - 3 wheels cutter kit**

**40-W052**



**Sugar gun**

**40-WA007**

Il kit include 20 dischetti intercambiabili  
The kit includes 20 interchangeable discs



**Cutter effetto imbottitura  
Quilted effect cutter**

**40-W198V**

Misura-Size: 120x90mm

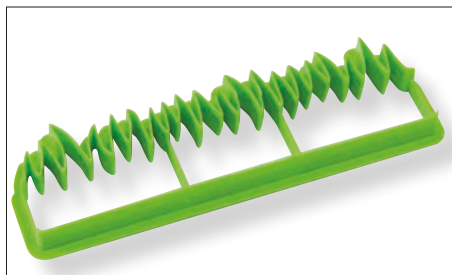

**Cutter erba - Grass cutter**

**40-W199V**

206x58mm



**Cutter bisturi - Scalpel cutter**

**40-W031**

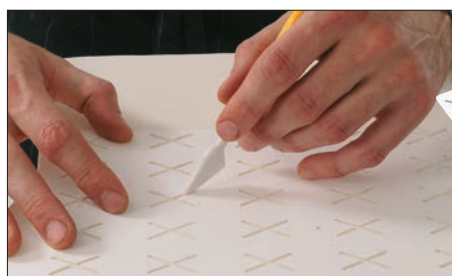

**Stencil rombi per effetto imbottitura  
Rhomb stencil for quilted effect**

**40-W108**

Misura-Size: 200x330mm





**Fiocchi neve - Snowflakes**

**40-W010S**

Ø25mm - Ø40mm - Ø56mm



**Agrifoglio - Holly**

**40-W043S**

22x20mm - 30x28mm - 45x40mm

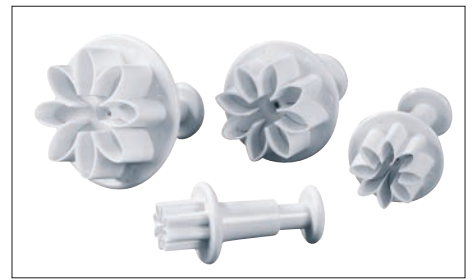

**Margherita - Daisy**

**40-W014S**

Ø12 - 18 - 25 - 33mm



**Fiore 6 petali - 6 petals flower**

**40-W161S**

Ø14 - 18 - 25 - 33mm



**Foglie rosa - Rose leaves**

**40-W016S**

27x19 - 32x21 - 40x27mm



**Ovali doppio taglio - Double cutter**

**40-W026**

33x23 - 30x20 - 49x33 - 44x28  
68x46 - 60x40 - 86x60 - 78x50mm



**Cuoricini - Hearts**

**40-W013S**

6x7mm - 8x10mm - 13x14mm

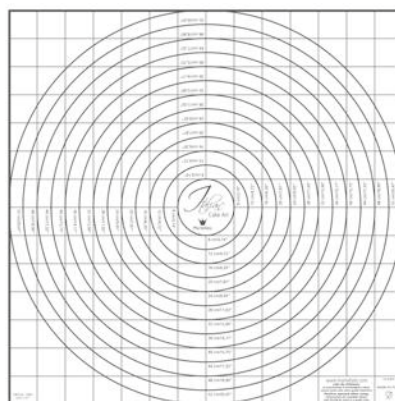

**Tappeto stendipasta in plastica - Plastic mat for dough rolling out  
con gommatura antiscivolo - with non-slip rubber coating**

**40-W167** - 60x58cm

# AIRBRUSHES

**Aeropenne professionali** per colorare cioccolato e dolci, alimentate per gravità con forma ad imbuto per una facile pulizia e un flusso di colorante più efficiente. Presentano un regolatore di flusso ad azione singola o doppia e sono disponibili diverse misure di ugelli e capacità di serbatoi per adattarsi ad ogni esigenza di decorazione, rispondendo alle diverse necessità di precisione e velocità.

**Professional airbrushes** for colouring chocolate and sweets, gravity-fed funnel-shaped cup for a easy cleaning and a more efficient dye flow. They have a single or double action flow regulator and different nozzle sizes and tank capacities are available to adapt to any decoration need, responding to different precision and speed requirements.



**DECOAIR 2**  
Cap. 7 CC  
Ugello/Nozzle Ø 0,3mm  
DUAL ACTION



**DECOAIR 3**  
Cap. 2 CC  
Ugello/Nozzle Ø 0,2mm  
DUAL ACTION



**DECOAIR 5**  
Cap. 20 CC - 40 CC  
Ugello/Nozzle Ø 0,2mm  
DUAL ACTION



**DECOAIR 6**  
Cap. 2 CC - 5 CC - 13 CC  
Ugello/Nozzle Ø 0,3mm  
SINGLE ACTION

**Dispositivo professionale portatile per la nebulizzazione del colorante alimentare.** Funzionamento con pistone in teflon senza olio di lubrificazione. Pressione di esercizio costante garantita dal regolatore. Una soluzione perfetta per tutti i lavori di aerografia e nebulizzazione del colorante alimentare.

**Portable professional device for the atomisation of food dye.** Operation with teflon piston without lubrication oil. Constant working pressure guaranteed by the regulator. A perfect solution for all airbrushing and atomising of food dye.



**DECOMP 7**  
4 BAR Potenza - Power: 1/5 HP  
Volume aria min./litres - Air output per min./litres: 23-25L/min  
Voltaggio - Voltage: 220-240V / 50HZ 110-120V/60HZ 220V / 60HZ  
Pressione Massima - Max.pressure: 6.5bar/95PSI



**DECOMP 9**  
6 BAR - Potenza - Power: 1/3 HP  
Volume aria min./litres - Air output per min./litres: 30-35L/min  
Voltaggio - Voltage: 220-240V / 50HZ 110-120V/60HZ 220V / 60HZ  
Pressione Massima: Max.pressure: 6.5bar/95PSI  
cavo di collegamento per aerografo incluso connection cable for airbrush included

# MINI AIRBRUSH

## DECOCP02

Il kit completo per piccole decorazioni include:

- Penna aerografa a doppia azione, Ø 0,2mm;
- Mini Compressore da 1,5 BAR;
- Supporto per penna aerografa; • Borsa nera da viaggio.

Complete kit for small decorations includes:

- Airbrush double action, Ø 0.2mm;
- Mini compressor 1,5 BAR;
- Support for airbrush; • Black travel bag.



## ACCESSORIES



**DECOF01**  
Filtro aerografo  
Airbrush filter

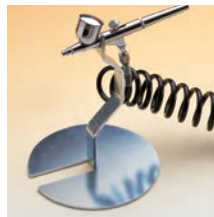

**MD 2**  
Sostegno aerografo  
Airbrush holder



**DECOH01**  
Sostegno aerografo  
Airbrush holder

## STENCIL

Realizzati in resistente materiale plastico traslucido, gli stencil per aerografia permettono di produrre decorazioni su superfici verticali e curve. Ideali per decorare torte da ricorrenza personalizzate.

Made of resistant translucent plastic material, the airbrush stencils allow you to produce decorations on vertical and curved surfaces. Ideal for decorating personalized cakes.

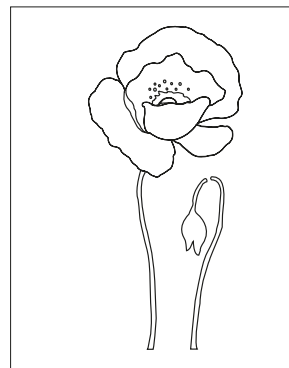

**40-WM038**  
Papavero grande e bocciolo  
Big poppy and bud stencil  
130x65 mm



**40-WM039**  
Papaveri e bocciolo  
Big, small and bud poppy  
110x62 mm - 60x30 mm



**40-WM007**  
Farfalle - Butterflies  
92x78mm - 50x43mm



**40-WM027**  
Rosa aperta - Open rose  
93x150mm



**40-WM042**  
Loto - Lotus Flower  
106x101mm



**40-WM506**  
Loto - Lotus Flower  
132x152mm KIT 2 STENCIL



**40-WM045**  
Savana  
230x230mm

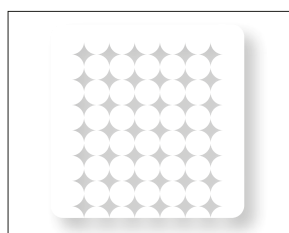

**40-WR002**  
Pois  
230x230mm

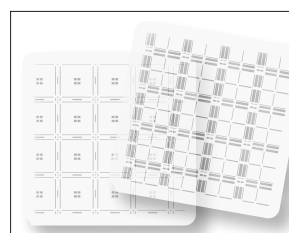

**40-WR003**  
Tartan  
230x230mm KIT 2 STENCIL

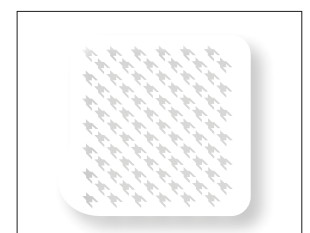

**40-WM046**  
Pied de poule  
230x230mm

# STENCIL

## *Decorative*

Pratici e veloci stencil per decorare torte, vaschette gelato, piatti e qualsiasi altro dessert. In materiale plastico per alimenti. Misure: Ø260mm. Spessore 0,8 mm

Practical and fast stencils to decorate cakes, ice cream, dishes and any other dessert. Made of food safe plastic. Sizes: Ø260mm. Thickness 0,8 mm





## MINI STENCIL

In materiale plastico per alimenti.  
 Misure: Ø95mm. Spessore 0,8 mm  
 Made of food safe plastic.  
 Sizes: Ø95mm. Thickness 0,8 mm

**Ideali per monoporzioni**  
**Ideal for single serving**



cap. 450 g  
**SETACIOK2**  
 Ø73 h120mm

**KITMS1**  
 Kit 10 pcs

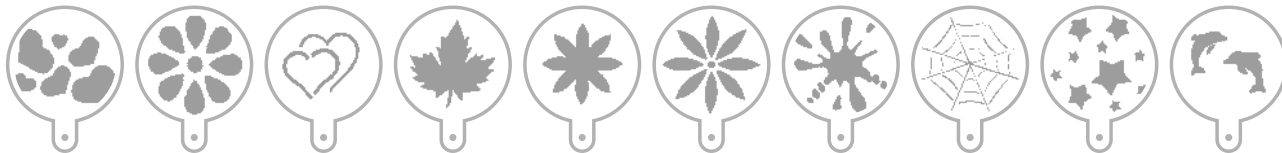

**KITMS2**  
 Kit 10 pcs



**KITMS4**  
 Kit 4 pcs



## CREATIVE STENCIL

Stencil in plastica bianca  
White plastic stencil  
Misura - Size: 295x200mm



**PMFORK**  
30x125 x h1,5mm - 12pcs



**PMSPOON**  
30x130 x h1,5mm - 12pcs

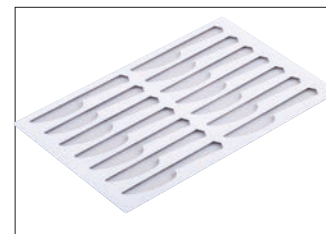

**PMKNIFE**  
20x130 x h1,5mm - 14pcs

Stencil in plastica trasparente/Transparent plastic stencil.  
Misura - Size: 310x510mm

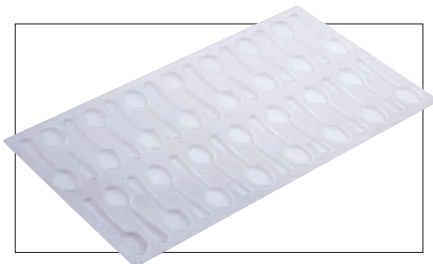

**SCSP01**  
130x30 x h2mm - 30pcs



**SCSP03**  
75x35x h2mm - 40pcs

## DECORATING TOOLS



**Coltello - Knife**  
**50WA006B**  
1 coltello / 1 knife



**Kit Attrezzi decoro - Modelling tool set**  
**50WA004B**  
12 strumenti doppia punta + 1 coltello +  
1 raschietto/12 dual-heads tools + 1 knife +  
1 scraper



**Kit Attrezzi decoro - Modelling tool set**  
**50WA005B**  
12 strumenti doppia punta + 1 coltello +  
1 raschietto/12 dual-heads tools + 1 knife +  
1 scraper



**Coltello - Knife**  
**40-WA006V**  
1 coltello / 1 knife

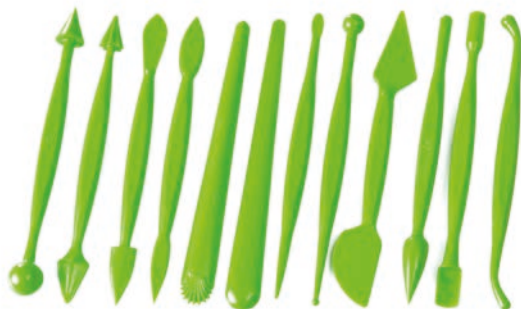

**Kit Attrezzi decoro - Modelling tool set**  
**40-WA004V**  
12 strumenti doppia punta  
12 dual-heads tools

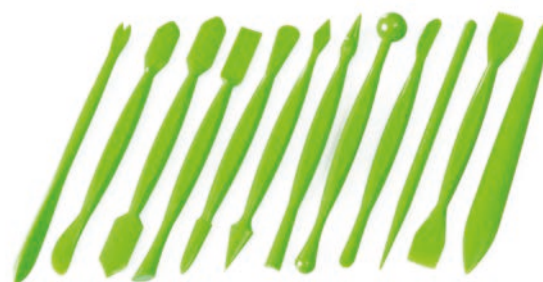

**Kit Attrezzi decoro - Modelling tool set**  
**40-WA005V**  
12 strumenti doppia punta  
12 dual-heads tools

# DECORATIVE STENCIL

Griglie in materiale plastico per creare decori con il cioccolato e con biscuit.  
Plastic grills for chocolate and biscuit decorations.

Spessore/Thickness: 8 mm

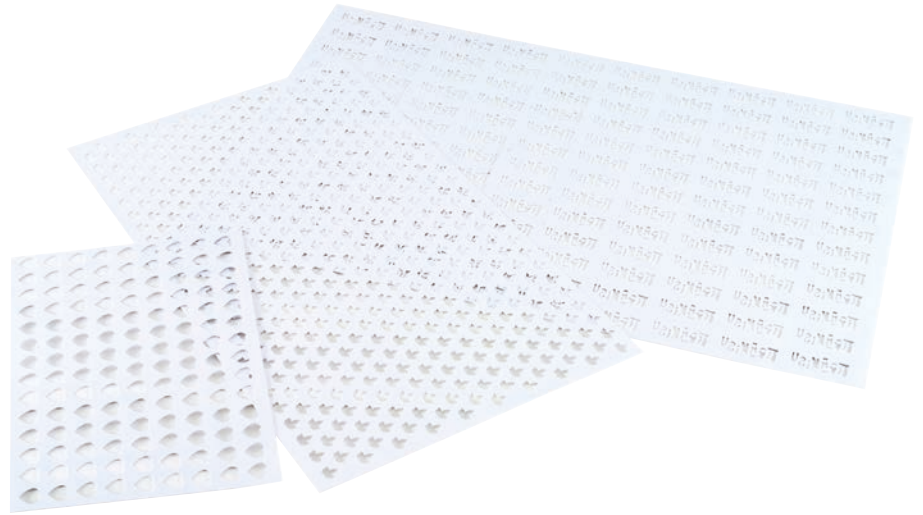

Size cm	Cod.
60x40	GD 03
30x20	GS03

Decoro/decor.: Ø6 mm

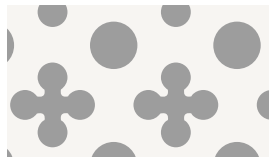

Size cm	Cod.
60x40	GD 04
30x20	GS04

Decoro/decor.: 11 mm



Size cm	Cod.
60x40	GD 06

Decoro/decor.: 17 x 17 mm



Size cm	Cod.
60x40	GD 07

Decoro/decor.: 20 x 3 mm

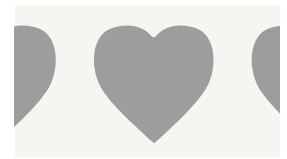

Size cm	Cod.
60x40	GD 08

Decoro/decor.: 16 x 16 mm



Size cm	Cod.
60x40	GD 09

Decoro/decor.: 9 x 7,5 mm



Size cm	Cod.
60x40	GD 10

Decoro/decor.: 15 x 6,5 mm



Size cm	Cod.
60x40	GD 05

Decoro/decor.: 9 x 9 mm



Size cm	Cod.
60x40	GD 11
30x20	GS11

Decoro/decor.: 9 x 9 mm



Size cm	Cod.
60x40	GD 13

Decoro/decor.: 13 x 15 mm



Size cm	Cod.
60x40	GD 14

Decoro/decor.: 20 x 15 mm



Size cm	Cod.
60x40	GD 15

Decoro/decor.: 175 x 282 mm

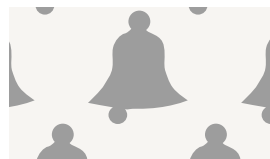

Size cm	Cod.
60x40	GD 16

Decoro/decor.: 14 x 15 mm

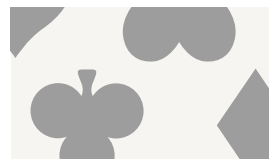

Size cm	Cod.
60x40	GD 17
30x20	GS17

Decoro/decor.: max15x15 mm



Size cm	Cod.
60x40	GD 18

Decoro/decor.: 14 x 10 mm



Size cm	Cod.
60x40	GD 01

Decoro/decor.: Ø6,5 mm



Size cm	Cod.
60x40	GD 02

Decoro/decor.: Ø9,5 mm



Size cm	Cod.
60x40	GD 12

Decoro/decor.: Ø15 mm



Size cm	Cod.
60x40	GD 21
30x20	GS21

Decoro/decor.: 13 x 15 mm



Size cm	Cod.
60x40	GD 22
30x20	GS22

Decoro/decor.: 50 x 15 mm

# DECORATIVE COMBS

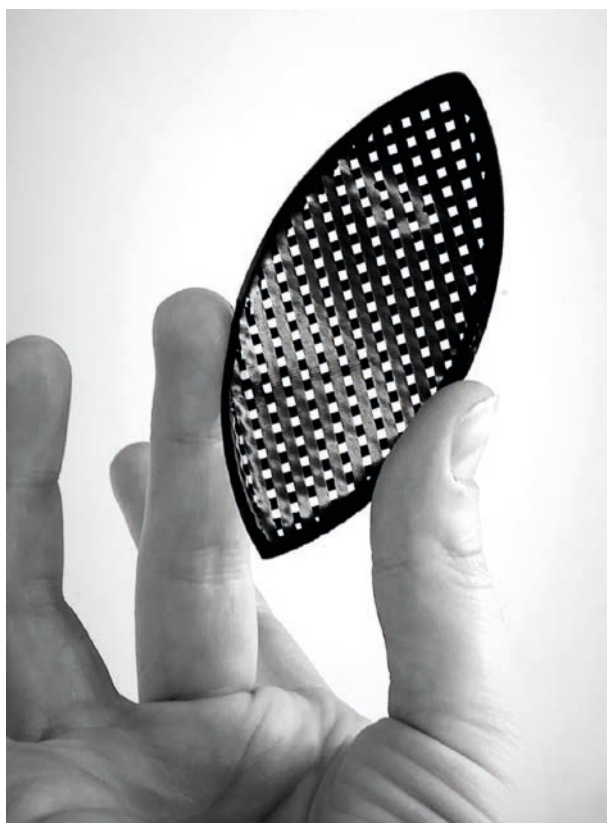
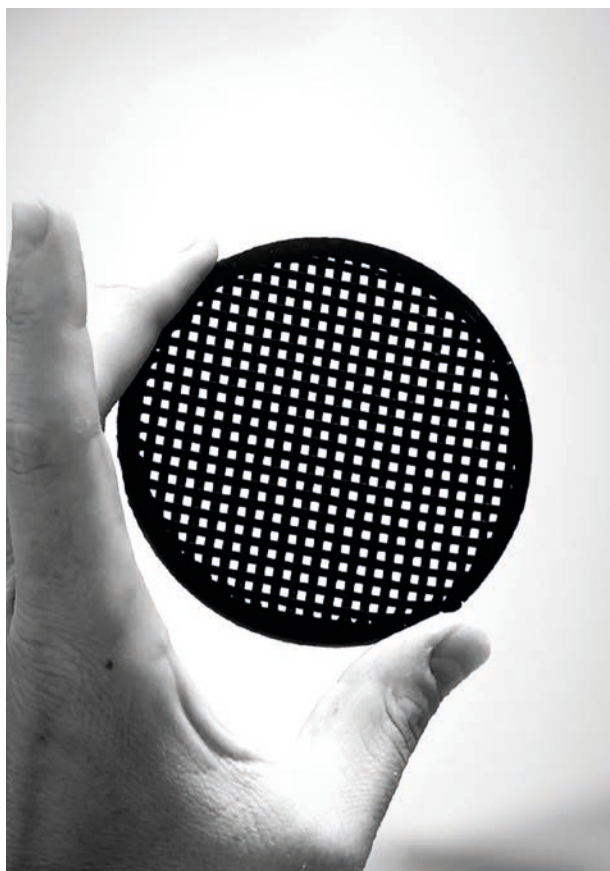

Pettini in materiale plastico e gomma con doppio decoro, ideali per biscuit e cioccolato.

Combs in plastic and rubber with double decoration, ideal for biscuits and chocolate.

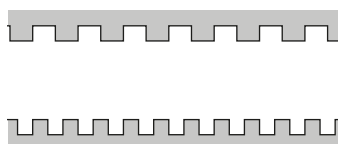

cm	Cod.
70	PD1/2
34	PDM1/2
17	PDS1/2

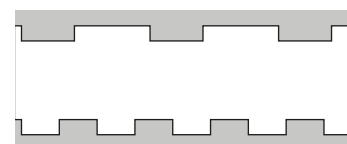

cm	Cod.
70	PD3/4
34	PDM3/4
17	PDS3/4

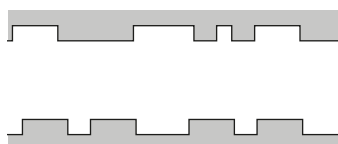

cm	Cod.
70	PD5/6
17	PDS5/6

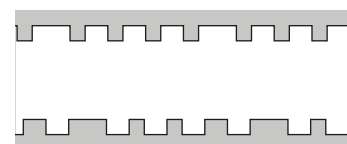

cm	Cod.
34	PDM7/8

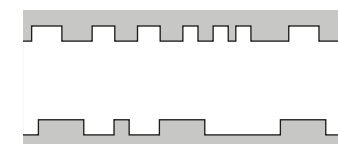

cm	Cod.
34	PDM9/10

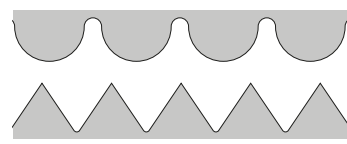

h cm	Cod.
70	PD13/14



**Pettine per decorazioni a 3 colori**  
**Three-colour decorating comb**

**PD11/12** - 70cm

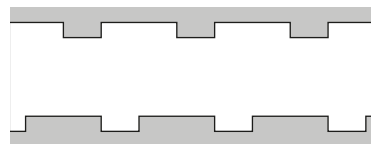

Pettini in materiale plastico per triplo decoro.  
 Plastic combs for triple decoration.

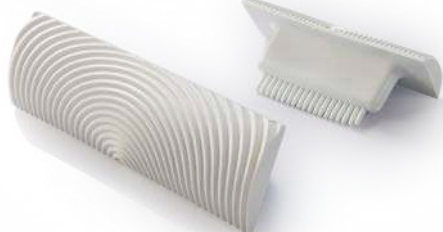

**Tampone effetto legno**  
**Wood motif decoration comb**  
 materiale plastico - plastic

**TFL10** - 10cm

**TFL15** - 15cm

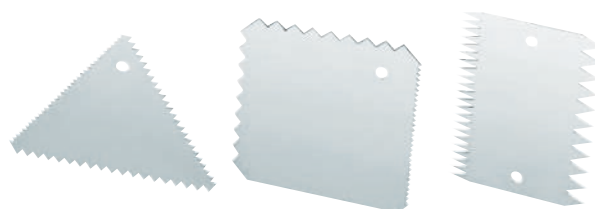

**Pettini da decoro/Decorative combs**

Acciaio inox/Stainless steel 18/8  
 Spessore/Thickness 0,50 mm

**INOX 3**

Triangular 100x103 mm - Square 100x100 mm -  
 Rectangular 56x110 mm

## DECORATIVE MATS

Tappeto in silicone per decori in rilievo. Silicone carpet for embossed decorations.  
 Size: 565x370 mm



**RELIEF1**

Misura - Size:  
 h 37mm

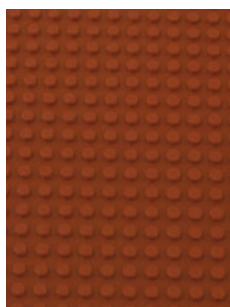

**RELIEF2**

Misura - Size:  
 Ø 4mm



**RELIEF4**

Misura - Size:  
 h 30mm

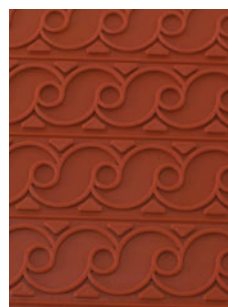

**RELIEF5**

Misura - Size:  
 h 30mm

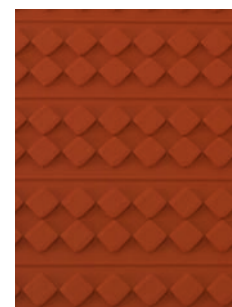

**RELIEF7**

Misura - Size:  
 h 30mm



**RELIEF8**

Misura - Size:  
 h 30mm

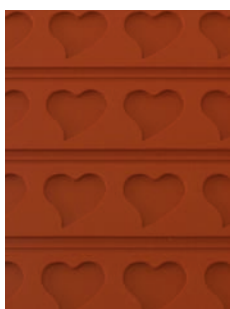

**RELIEF9**

Misura - Size:  
 h 30mm



**RELIEF10**

Misura - Size:  
 h 30mm



**RELIEF11**

Misura - Size:  
 h 30mm



**RELIEF12**

Misura - Size:  
 h 30mm



# BANQUETING & DISPLAY

# ELEGANT

CATERING SOLUTION

Design e qualità contraddistinguono gli eleganti ed infrangibili articoli ideali per ogni professionista del settore HORECA, della pasticceria e della gelateria. **Realizzati da Martellato** con materiale di alta qualità, che conferisce, oltre alla resistenza, anche lucidità e trasparenza. Prodotti in Italia, gli articoli Martellato rappresentano la più valida alternativa al vetro.

Design and quality characterise the elegant and unbreakable disposable items ideal for every professional in the HORECA, pastry and ice-cream sector. **Made by Martellato** with high quality material, which gives, in addition to resistance, also lucidity and transparency. Produced in Italy, the Martellato items provide the most valid alternative to glass.



## I RIUTILIZZABILI

**Rispettano l'ambiente due volte.** Grazie al materiale di alta qualità con il quale sono prodotti, i piatti per individual dessert - così come tutti i gli articoli della linea Elegant Catering Solution - **possono essere riutilizzati più volte.** E una volta gettati, sono riciclabili al 100%.

## THE REUSABLE

**They respect the environment twice.** Thanks to the high quality material with which they are made, the plates for individual desserts - like all the items of the Elegant Catering Solution line - **can be reused several times.** And once disposed, they are 100% recyclable.



## SLICE

**Coppetta/Cup**

**PMOFT001**

135 x 69 x h 42 mm - cap. 160 ml  
pack 100 pcs

**Coperchio/Lid**

**PMOFT001C**

pack 100 pcs

**Tagliapasta/Cutter**  
**Slice**

**31CUT04**





## ECLAIR

### Coppetta/Cup

**PMOCL001**

137 X 37 h 41 mm - cap. 120 ml  
pack 100 pcs

### Coperchio/Lid

**PMOCL001C**

pack 100 pcs

**Tagliapasta  
Eclair 25x125mm  
31CUT01**





## BUCKET

Coppetta/Cup

**PMOTO005**

Ø78 h 57 mm - cap. 210 ml  
pack 100 pcs

Coperchio/Lid

**PMOTO005/C**

pack 100 pcs

Tagliapasta  
Bucket Ø78mm

**31CUT03**



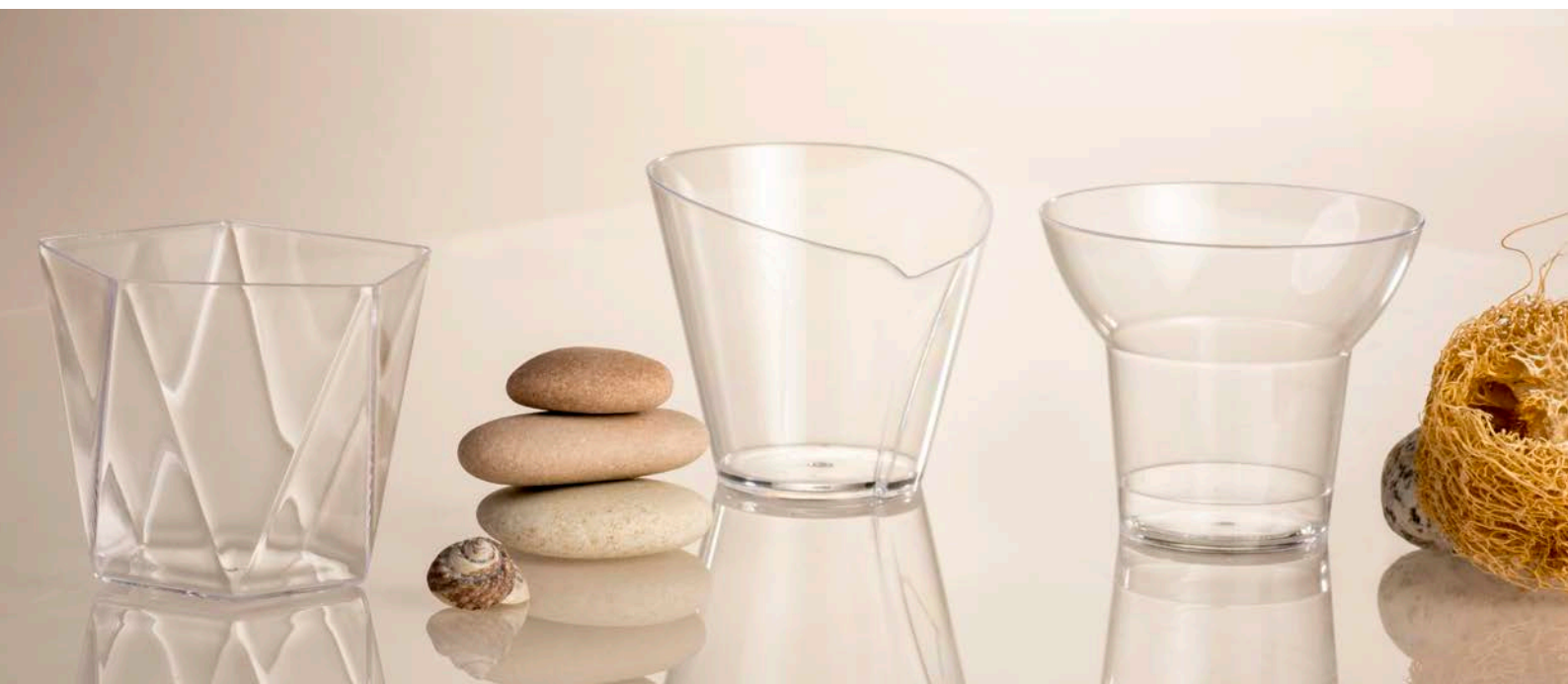

## PENTA

**CAP. 120 ML**  
68x65 h 56 mm

**PMOPE001** - pack 100 pz



## WAFLE

**CAP. 70 ML**  
64x62 h 59 mm

**PMOCO013** - pack 100 pz



## SOFT ICE

**CAP. 105 ML**  
Ø70 h 59 mm

**PMOCO014** - pack 100 pz



## GREEK

**CAP. 190 ML**

92x90 h 75 mm

**PMOCO010** - pack 100 pz

**CAP. 120 ML**

73x71 h 61 mm

**PMOCO009** - pack 100 pz

**CAP. 50 ML**

50x48 h 57 mm

**PMOCO008** - pack 100 pz



## WAVE

**CAP. 200 ML**

100x70 h 83 mm

**PMOCE003** - pack 100 pz

**CAP. 120 ML**

85x60 h 70 mm

**PMOCE002** - pack 100 pz

**CAP. 50 ML**

64x46 h 53 mm

**PMOCE001** - pack 100 pz



## VELA

**CAP. 200 ML**

90x83 h 74 mm

**PMOCO015** - pack 100 pz

**CAP. 140 ML**

73x81 h 67 mm

**PMOCO012** - pack 100 pz

**CAP. 85 ML**

63x69 h 57 mm

**PMOCO011** - pack 100 pz



## CUBÒ

**CAP. 58 ML**

50x50 h 55 mm

**PMOCU004** - pack 100 pz



**COPERCHI/LIDS**

**PMOCU002/C** - pack 100 pz



## TRIANGLE

**CAP. 175 ML**

81x83 h 65 mm

**PMO07.00** - pack 100 pz



**COPERCHI/LIDS**

**PMO07/C** - pack 100 pz



## JAPAN

**CAP. 87 ML**

Ø50 h 54 mm

**PMOJA002** - pack 100 pz

**CAP. 47 ML**

Ø42 h 43 mm

**PMOJA001** - pack 100 pz



## HEART

**CAP. 100 ML**  
73x64 h 52 mm

**PMOLO001** - pack 100 pz



**COPERCHI/LIDS**  
**PMOLO001/C** - pack 100 pz



## CUP

**CAP. 150 ML**  
Ø75 h 73 mm

**PMOCO003** - pack 100 pz

**CAP. 135 ML**  
Ø70 h 67 mm

**PMOCO002** - pack 100 pz

**CAP. 90 ML**  
Ø65 h 55 mm

**PMOCO001** - pack 100 pz



## DROP

**CAP. 190 ML**  
Ø75 h 80 mm

**PMOCO006** - pack 100 pz



## CYLINDER

**CAP. 190 ML**  
Ø65 h 85 mm  
**PMOCO007** - pack 100 pz



## BUBBLE

**CAP. 215 ML**  
Ø90 h 75 mm  
**PMOCO004** - pack 100 pz



## CONE

**CAP. 165 ML**  
Ø90 h 75 mm  
**PMOCO005** - pack 100 pz



## CLASSIC

**CAP. 170 ML**  
Ø60 h 90 mm  
**PMOTO004** - pack 100 pz

**CAP. 120 ML**  
Ø55 h 70 mm  
**PMOTO003** - pack 100 pz



## CLASSIC

**CAP. 90 ML**  
Ø50 h 65 mm  
**PMOTO002** - pack 100 pz

**CAP. 65 ML**  
Ø42 h 65 mm  
**PMOTO001** - pack 100 pz



## TUBE

**CAP. 80 ML**  
Ø40 h 85 mm  
**PMO08.00** - pack 100 pz



## SQUARE

**CAP. 175 ML**  
57x57 h 73 mm

**PMOCU003** - pack 100 pz



**COPERCHI/LIDS**  
**PMOCU003/C** - pack 100 pz



## SQUARE

**CAP. 125 ML**  
50x50 h 70 mm

**PMOCU002** - pack 100 pz



**COPERCHI/LIDS**  
**PMOCU002/C** - pack 100 pz



## SQUARE

**CAP. 60 ML**  
40x40 h 55 mm

**PMOCU001** - pack 100 pz



## TONDO

85x96 h 20 mm - pack 100 pz  
**PL00100** - trasparente/clear  
**PL00101** - bianco/white  
**PL00102** - nero/black



## QUADRO

80x97 h 20 mm - pack 100 pz  
**PL00200** - trasparente/clear  
**PL00201** - bianco/white  
**PL00202** - nero/black



## RETTANGOLO

60x140 h 20 mm - pack 100 pz  
**PL00300** - trasparente/clear  
**PL00301** - bianco/white  
**PL00302** - nero/black



## ZEN BOWL

**CAP. 460 ML**  
 100x118 h 70 mm - pack 50 pz  
**ZENB000** - trasparente/clear  
**ZENB001** - bianco/white  
**ZENB002** - nero/black



## ZEN SMALL TRAY

100x118 h 6 mm - pack 50 pz  
**ZENB000C** - trasparente/clear



## ZEN TRAY

110x245 h 180 mm - pack 50 pz  
**ZENTR00** - trasparente/clear  
**ZENTR01** - bianco/white  
**ZENTR02** - nero/black





## MINI BOWL

**CAP. 50 ML**

75 x 75 h 30 mm - pack 100 pz

**PMO11.00** - trasparente/clear

**PMO11.01** - bianco/white

**PMO11.02** - nero/black



## TRIANGLE

**CAP. 20 ML**

85 x 85 h 15 mm - pack 100 pz

**PMO09.00** - trasparente/clear

**PMO09.01** - bianco/white

**PMO09.02** - nero/black



## BLOW

**CAP. 30 ML**

85 x 85 h 30 mm - pack 100 pz

**PMO10.00** - trasparente/clear

**PMO10.01** - bianco/white

**PMO10.02** - nero/black



## WING

**CAP. 11 ML**

105 x 50 h 30 mm - pack 100 pz

**PMO12.00** - trasparente/clear

**PMO12.01** - bianco/white

**PMO12.02** - nero/black



## SINGLE

**CAP. 15 ML**

65 x 65 h 15 mm - pack 100 pz

**PMO13.00** - trasparente/clear

**PMO13.01** - bianco/white



## DOUBLE

**CAP. 20 ML**

110 x 65 h 20 mm - pack 100 pz

**PMO14.00** - trasparente/clear



**CAP. 120 ML**

Ø72 h 51 mm - pack 100 pz

**PMOVA002.00** - trasparente/clear



**CAP. 120 ML**

Ø75,5 h 35 mm - pack 100 pz

**PMOVA003.00** - trasparente/clear



**CAP. 120 ML**

Ø67,5 h 58 mm - pack 100 pz

**PMOVA001.00** - trasparente/clear

# CATERING DISPLAYS

Eleganti espositori in plexiglass dal **design ricercato e moderno, prodotti in Italia**. Sono ideali per allestire raffinati buffet per **cerimonie** o **incontri d'affari**. Resistenti e facili da montare e trasportare, sono completamente atossici.

Elegant plexiglass displays with **modern design, produced in Italy**. They are ideal for setting up refined buffets for **ceremonies** or **business meetings**. Resistant and easy to assemble and transport, they are completely non-toxic.

**MADE IN ITALY**





## FOLD SINGLE

**80D0900**

Ingombro/total size: 32,5 x 33,5 h 18 cm

Superficie di appoggio/support surfaces 16,5 x 32,5 cm



## FOLD DOUBLE

**80D1000**

Ingombro/total size: 65 x 33,5 h 18 cm

Superficie di appoggio/support surfaces 16,5 x 65 cm



## MOSAIC

- 80D0600 - MOSAIC 4** - Misura/size: Ø 24 h 4,5 cm
- 80D0700 - MOSAIC 8** - Misura/size: Ø 24 h 8,5 cm
- 80D0800 - MOSAIC 12** - Misura/size: Ø 24 h 12,5 cm



## MOSAIC KIT

- 80D0500**  
Kit 3 displays: Ø 24 h 4,5 - 8,5 - 12,5 cm



## CROSS

### 80D0200 - CROSS SMALL

Misura/size: 25 x 25 h 13,5 cm

### 80D0300 - CROSS BIG

Misura/size: 30 x 30 h 18,5 cm

### 80D0400 - CROSS DOUBLE

Misura/size: 20 x 49,5 h 13,5 cm

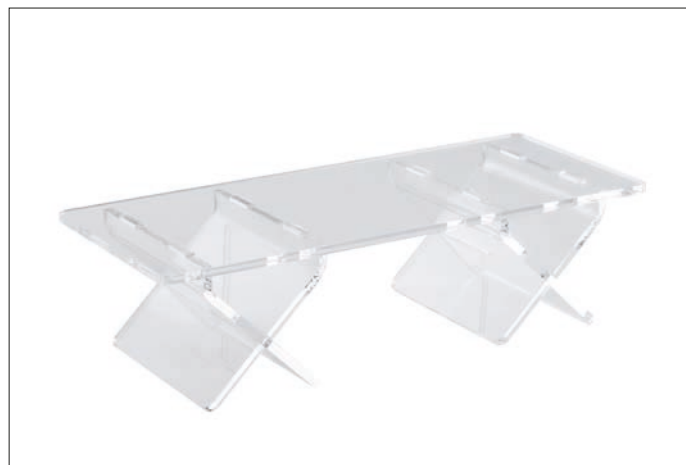

## CROSS DOUBLE

### 80D0400 - CROSS DOUBLE

Misura/size: 20 x 49,5 h 13,5 cm

## CROSS KIT

### 80D0100 - CROSS KIT

Kit 3 displays: 25 x 25 h 13,5 cm + 30 x 30 h 18,5 cm + 20 x 49,5 h 13,5 cm



## STAIRWAY

### 80D1900

4 Piani/levels: 35 x 35 h 26 - 30 x 30 h 21 - 25 x 25 h 16 -  
20 x 20 h 12 cm

Componibili in infinite varianti per creare originali effetti coreografici/Combinable in endless variations, they can offer original coreographic effects.

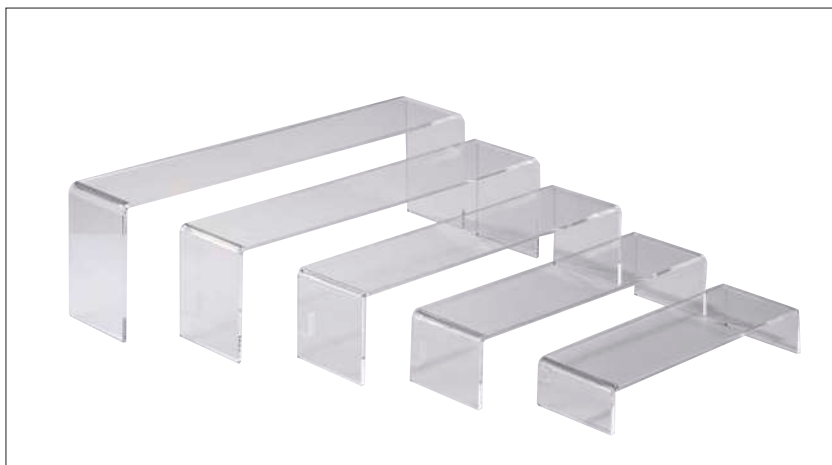

## LEVELS

### 80D2000

5 Piani/levels: 50 x 10 h 15 - 45 x 10 h 12,5 - 40 x 10 h 10 - 35 x 10 h 7,5 - 30 x 10 h 5 cm

Componibili in infinite varianti per creare originali effetti coreografici/Combinable in endless variations, they can offer original coreographic effects.



**COD33501**

Display in plexiglass satinato e bianco/satin-finish and white plexiglass display

Misura/size: h 50,5 cm

Piatti/plates: 63,5 x 35 - 52,5 x 25,5 - 43x21,5 - 35 x 19 - 28 x 14,5 cm

Distanza tra ripiani/distance between shelves: 12 cm

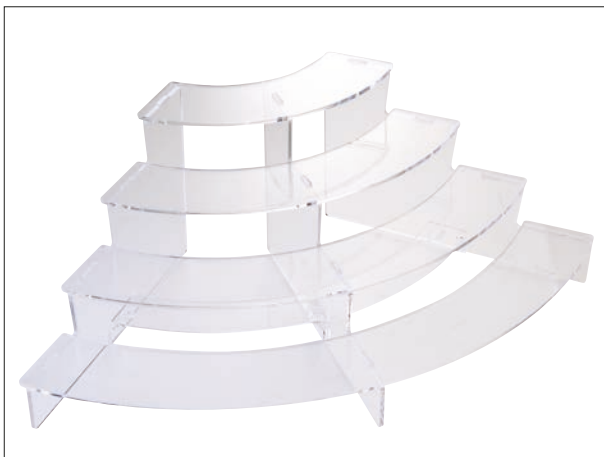

**COD. 320**

Misura/size: h 22,5 cm  
Piatti/plates: 65 x 35,5 cm



**COD33701**

Piatti/plates: 50 x 20 h 20,5 - 50 x 20 h14 -  
50 x 20 h 7 cm

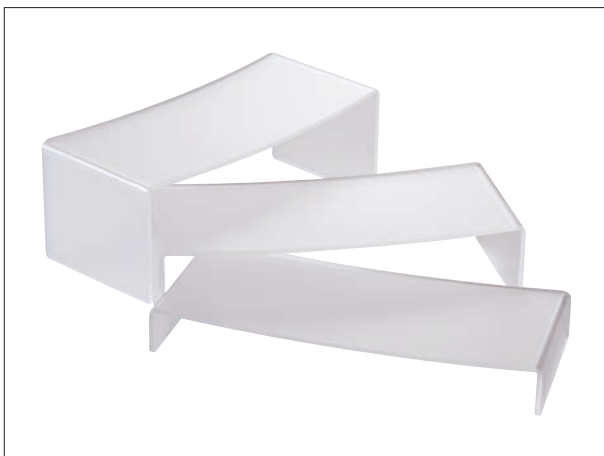

**COD33906**

Satinato/Satin-finish plexiglass  
Piatti/plates: 35,5x 17 h 22 - 7 x 17 h 9 -  
40 x 17 h 5 cm

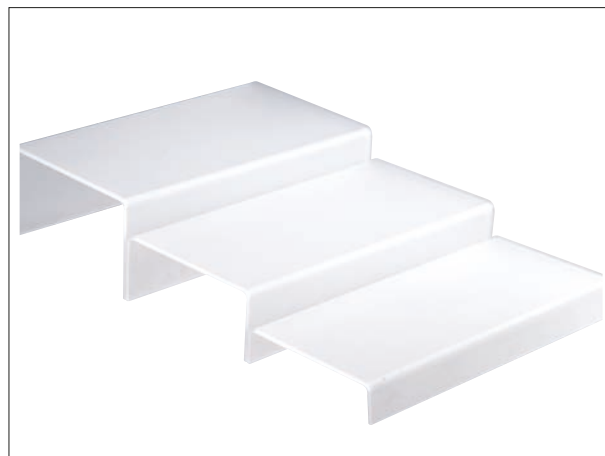

**COD. 310**

Piatti/plates: 40 x 20 h 12 - 40 x 18 h 8 -  
40 x 16 h 4 cm



**COD. 309**

Misura/size: h 4 - 11 - 18 - 25 cm  
Piatti/plates: 24,5 x 24,5 cm



**COD34001**

Piatti/plates: 49 x 15,5 h 18 - 49 x 15,5 h 13 -  
49 x 15,5 h 8 cm



**COD33401**

Misura/size: 42 x 42 h 30,5 cm  
 Piatti/plates: Ø 42 - 37 - 25 cm  
 Distanza tra ripiani/distance between shelves: 12 cm



**COD. 510**

Misura/size: 41 x 41 h 67 cm  
 Piatti/plates: 40 x 40 - 35 x 35 - 30 x 30 - 20 x 20 cm



**COD. 305**

Piatti/plates: Ø 28 h 29 - 38 x 30 h 21 - 38 x 30 h 13 - 38 x 30 h 5 cm



**COD. 307**

Misura/size: 40 x 27 h 29 - 40 x 27 h 21 - 40 x 27 h 13 - 40 x 27 h 5 cm



**COD33201**

Misura/size: 38 x 53,3 h 71 cm  
Piatti/plates: 2 piatti/plates 33 x 26 cm +  
2 piatti/plates 29 x 22 cm



**COD33301**

Misura/size: 34 x 34 h 37,5 cm  
Piatti/plates: Ø 34 - 26 - 15,5 cm  
Distanza tra ripiani/distance between  
shelves: 11 cm



**COD60501**

Misura/size: 49 x 49 x h 41 cm  
Piatti/plates: 49 x 49 - 39 x 39 - 29 x 29 -  
19 x 19 cm  
Distanza tra ripiani/distance between  
shelves: 12 cm



**COD. 603**

Misura/size: Ø 50 x h 58 cm  
Piatti/plates: Ø 50 - 42 - 34 - 26 - 18 cm

**COD. 32901**

Misura/size: 35 x 55,5 h 27 cm  
Piatti/plates: 35 x 25 - 30 x 12 -  
28 x 18 cm





**COD35101**

Misura/size: h 38 cm

Piatti/plates: 50 x 50 h 12 - 36 x 36 h 12 -  
22,5 x 22,5 h 12 cm



**COD. 604**

Misura/size: 22 x 27 h 30 cm



**COD33608 - Nero/black**

Misura/size: 65 x 35 h 27 cm

Piatti/plates: 37 x 26 - 30 x 22 - 22 x 16 cm



**COD. 32717 - Lilla/lilac**

Misura/size: 52 x 43,5 h 62 cm

Piatti/plates: 34 x 18 - 43x 23 - 46,5 x 25,5 -  
42,5 x 23,5 cm



Misura/size: 56 x 35 h 59 cm  
**COD32108 - Nero/black**  
**COD32100 - Bianco/white**  
**COD. 321 - Arancione/orange**



Misura/size: Ø 56 h 62 cm  
 Piatti/plates: Ø 56 - 46 - 33 - 22 cm  
**COD30408 - Nero/black**  
**COD30400 - Bianco/white**  
**COD. 304 - Verde/green**



**COD. 322 - Arancione/orange**  
 Misura/size: Ø40,5 h 49,5 cm  
 Piatti/plates: Ø40,5 - 39 - 38 - 35,5 - 31,5 cm



Misura/size: 45 x 30 h 61 cm  
 3 Piatti/plates: 32 x 24 cm  
**COD. 32418 - Rosa/pink**  
**COD. 32416 - Marrone/brown**

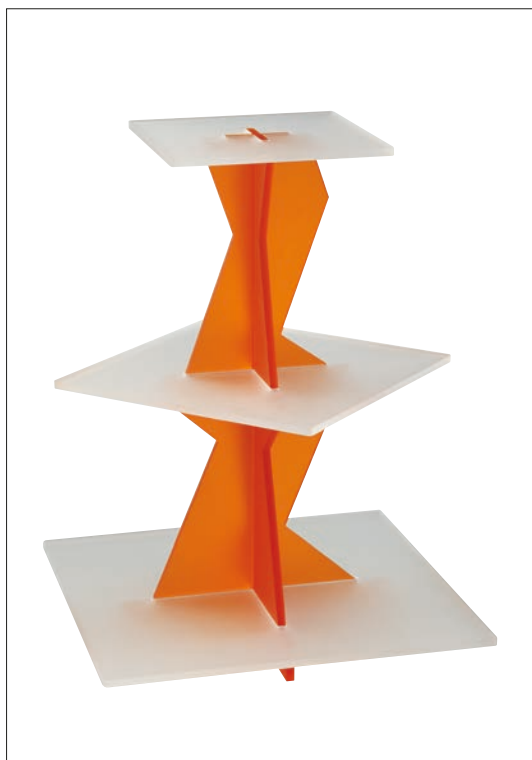

**COD. 308 - Arancione/orange**

Misura/size: 40 x 40 h 53 cm

Piatti/plates: 40 x 40 - 30 x 30 - 22 x 22 cm

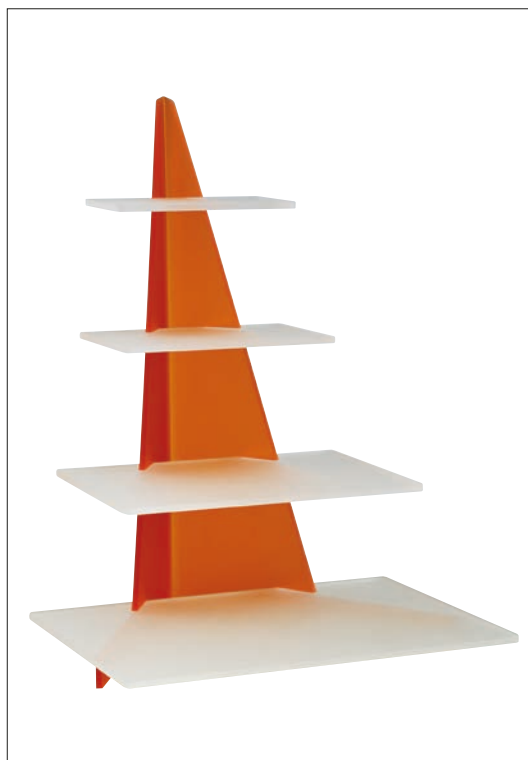

**COD. 300 - Arancione/orange**

Misura/size: 54 x 47 h 63 cm

Piatti/plates: 47 x 34 - 37 x 25 - 27 x 17 - 23 x 13 cm



**COD. 301 - Giallo/yellow**

Misura/size: 70 x 40 h 62 cm

Piatti/plates: 70 x 40 - 63 x 35 - 52 x 26 - 42 x 21 cm



**COD. 33118 - Rosa/pink**

Misura/size: h 3,6 - 11 - 17,6 - 25 cm

Piatti/plates: 24,5 x 24,5 cm

# CAKE STANDS

## LOOP

---



Serie di alzate in plexiglass **componibili** con elementi **intercambiabili** dal design moderno ed elegante. Da 3 a 5 piani a cerchio o semicerchio, con **colonne di diverse altezze** che grazie al kit possono comporre diversi disegni estetici.

An elegant and modern design serie of plexiglass **modular** cake stands with **interchangeable** elements. From 3 to 5 circle or half circle shaped shelves, with little **columns of different heights** that can create different easthetic designs.



## LOOP 5

**80A1400**

Misura/size: Ø 77 h 26 cm

5 Piatti/plates Ø26 cm

Columns: 1x h10 - 2x h18 - 2x h26 cm



## LOOP 3

**80A1500**

Misura/size: Ø 65 h 26 cm

3 Piatti/plates Ø26 cm

Columns: 1x h10 - 1x h18 - 1x h26 cm



## DEMI LOOP

**80A1600**

Misura/size: 65 x 45,5 h 35 cm

3 Piatti/plates Ø26 cm

Columns: 1x h10 - 1x h22 - 1x h35 cm

Kit complementari disponibili nella pagina seguente  
Complementary kits available on the following page

# LINEAR

---



Alzate componibili con elementi intercambiabili essenziali e minimalisti per esaltare l'esposizione delle creazioni. Adatte ai buffet ed alle vetrine. Le diverse misure ed altezze delle colonne le rendono modificabili e adatte a tutte le situazioni.

Essential and minimalist **modular** cake stands with **interchangeable elements** that enhance the exposition of creations. They are suitable either to buffets and showcases. The different sizes and heights of the **columns** make them **changeable** and suitable for all situations.



## LINEAR 5

**80A1800**

Misura/size: 140 x 26 h 26 cm

5 Piatti/plates Ø 26 cm

Columns: 2x h10 - 2x h18 - 2x h26 cm



## LINEAR 3

**80A1700**

Misura/size: 88 x 26 h 26 cm

3 Piatti/plates Ø 26 cm

Columns: 1x h10 - 1x h18 - 1x h26 cm

### KIT elementi intercambiabili per le alzate LOOP e LINEAR Interchangeable KITS to LOOP and LINEAR models



**80RIC02**

5 pcs Ø 26 cm



**80RIC04**

5 pcs 20 x 20 cm



**80RIC03**

5 pcs: 2x Ø20 - 2x Ø25 -  
1x Ø30 cm



**80RIC05**

6 pcs: 2x10 - 2x18 -  
2x 26 cm

# INFINITY

---



Alzata realizzata completamente in plexiglass, **configurabile in 3, 5 o 7 piatti** per soddisfare le diverse esigenze, completa di 18 colonnine che potranno facilmente essere inserite per comporre la torta.

Catering display made entirely of plexiglass, **configurable in 3, 5 or 7 plates** to meet different needs, complete with 18 small columns that can easily be inserted to compose the cake.



## INFINITY

### 80A1300

Misura/size: Ø 40 h 69 cm - 7 piatti

Misure piatti: Ø 16 - 20 - 24 - 28 - 32 - 36 - 40 cm

18 colonne/columns h 10 cm

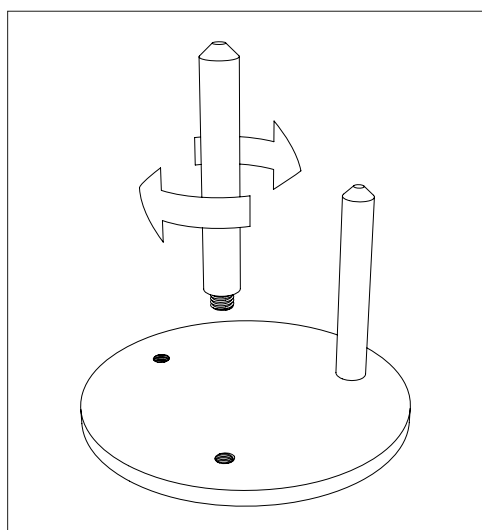

Dettaglio di montaggio delle colonne  
Column assembly detail

# BAROQUE

---



Romantiche nello stile e moderne nel materiale, queste alzate sono perfette per qualsiasi occasione, anche grazie alla gamma di colori. I **singoli elementi** possono, a seconda delle necessità, **comporsi in modo diverso** adattandosi agli spazi ed alle situazioni.

With a romantic style and modern materials, these cake stands are perfect in any occasion, thanks to its range of colours. **The individual elements** can, according to need, **compose themselves in different ways**, adapting to spaces and situations.



## CRYSTAL BAROQUE Ø26

trasparente/clear

**80A1100** - Kit 5 alzate/kit 5 displays

Misura/size: Ø 26 cm - 1 x h35 - 4x h 21cm

**80A0900** - 1 alzata/1 display

Misura/size: Ø 26 cm h 21 cm

**80A1000** - 1 alzata/1 display

Misura/size: Ø 26 cm h 35 cm



## BLACK BAROQUE Ø26

nero/black

**80A1108** - Kit 5 alzate/kit 5 displays

Misura/size: Ø 26 cm - 1 x h35 - 4x h 21cm

**80A0908** - 1 alzata/1 display

Misura/size: Ø 26 cm h 21 cm

**80A1008** - 1 alzata/1 display

Misura/size: Ø 26 cm h 35 cm



## MINI BAROQUE Ø21

satinato/glazed

**80-0106** - Misura/size: Ø 21 cm h 10,5 cm

**80-0206** - Misura/size: Ø 21 cm h 16,5 cm

**80-0306** - Misura/size: Ø 21 cm h 22,5 cm

**nero/black**

**80-0108** - Misura/size: Ø 21 cm h 10,5 cm

**80-0208** - Misura/size: Ø 21 cm h 16,5 cm

**80-0308** - Misura/size: Ø 21 cm h 22,5 cm

# MODULAR DISPLAY



## 3 PLATES

**COD512**

Misura/size: 67 x 37 h 21 cm

Piatti/plates: Ø 20 - 26 - 32 cm



## 5 PLATES

**COD514**

Misura/size: 100 x 53 h 39,5 cm

Piatti/plates: Ø 20 - 26 - 32 cm

## ALZATE COMPONIBILI

Combinando tra loro le alzate si possono avere le composizioni più adatte alle proprie necessità.  
By combining the stands you will have the compositions best suited to your needs.

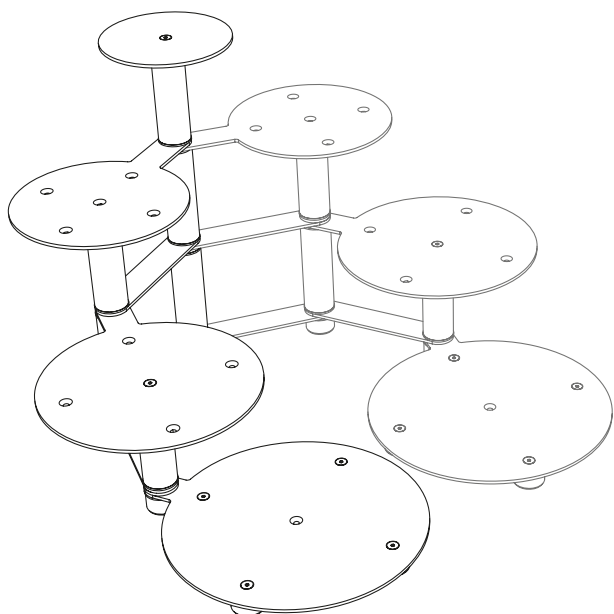

COD513 + COD513

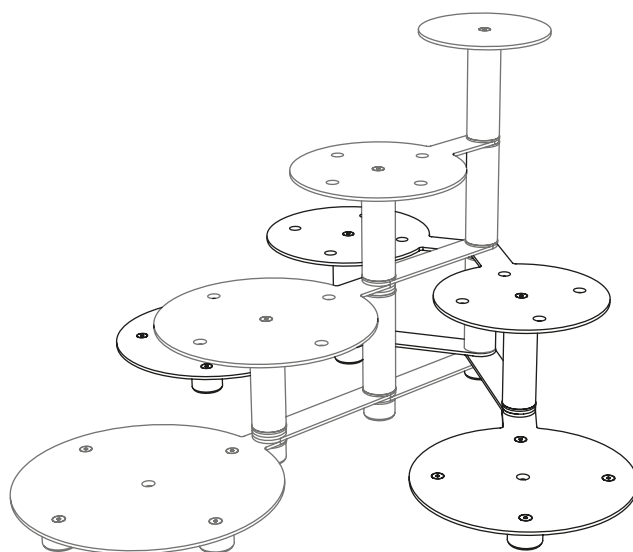

COD513 + COD514

## 4 PLATES

COD513

Misura/size: 70 x 65 h 56 cm

Piatti/plates: Ø 20 - 26 - 32 - 38 cm



Elegante alzata in plexiglass **modulabile**.  
Il numero di piatti e la loro disposizione  
possono essere variati a seconda delle  
necessità.

Elegant **modular** plexiglass cake stand.  
The number of plates and their  
arrangement can be varied as needed.

## ELEGANT

80A1900

Misura/size: h max 153 cm

Distanza tra i piatti/shelf spacing 16,5 cm

Piatti/plates: Ø 20 - 23,5 - 26,5 - 30 - 34  
- 38 cm





## ELEGANT

**80A1900**

Misura/size: h max 153 cm

Distanza tra i piatti/shelf spacing 16,5 cm

Piatti/plates: Ø 20 - 23,5 - 26,5 - 30 - 34 - 38 cm



## ROUND

**COD. 131**

Misura/size: h 80 cm

Piatti/plates: Ø 24 - 29 - 34 - 39 cm

Porzioni/portions: 40/50



## SQUARE

**COD. 130**

Misura/size: h 80 cm

Piatti/plates: 25 x 25 - 30 x 30 - 35 x 35 -

40 x 40 cm - Porzioni/portions: 80/85



## HEART

**COD. 132**

Misura/size: h 80 cm

Piatti/plates: 25 x 21 - 30 x 26 - 35 x 30 - 40 x 34 cm

Porzioni/portions: 40/50

# ROMANTIC

COD. 504

Misura/size: h 125 cm

Piatti in plexiglass satinato/Glazed plexiglass  
plates: Ø 20 - 22 - 26 - 28 - 30 cm



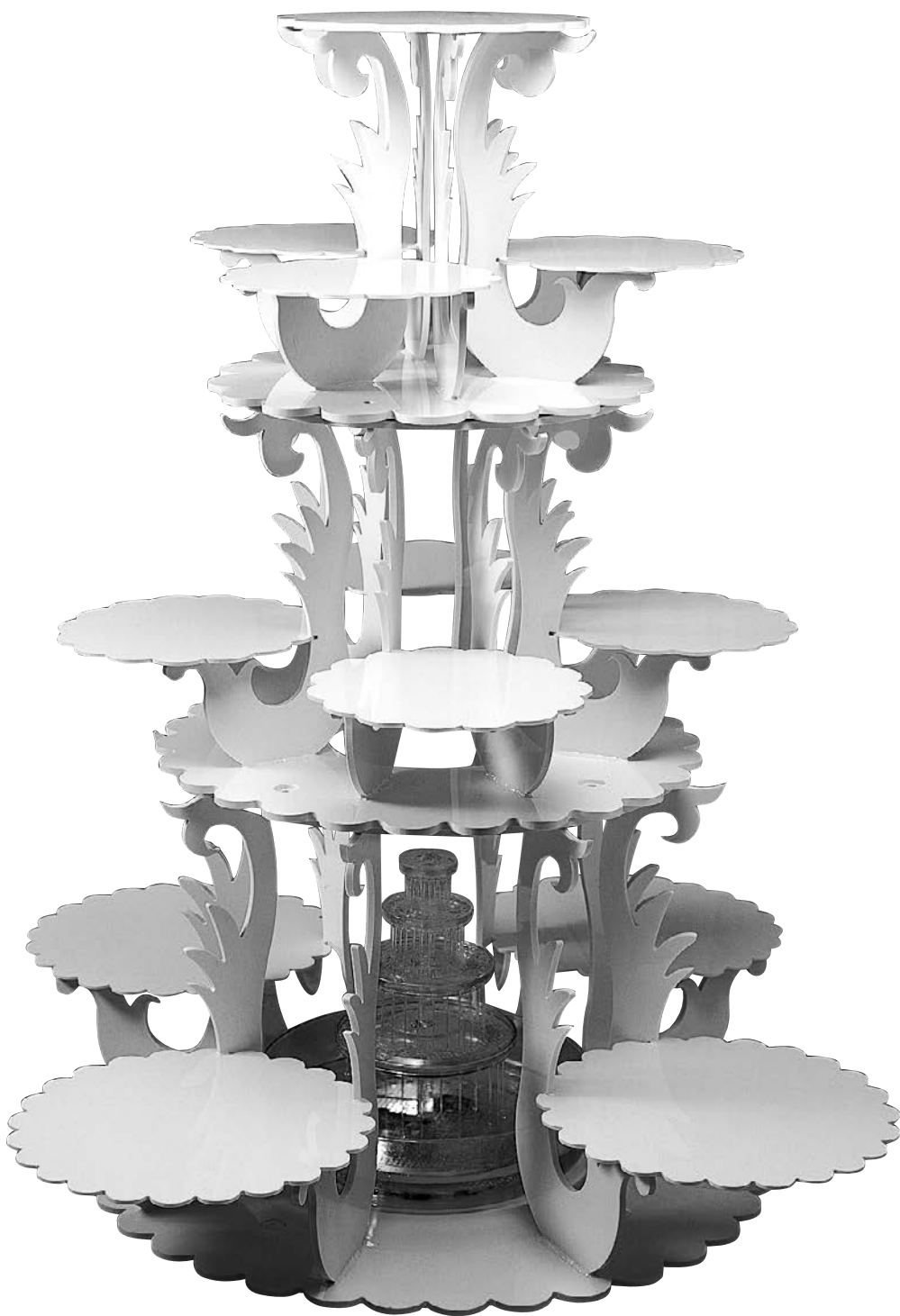

## FLORA COMPLETE

**COD. 160**

Misura/size: Ø 110 h 130 cm

Piatti/plates: 4x Ø 34 - 7 x Ø 26 - 1 x Ø 32 cm

Porzioni/portions: 145/155

FONTANINA non inclusa - not included



## FLORA SMALL

**COD. 163**

Misura/size: Ø 40 h 45 cm



## FLORA MEDIUM

**COD. 162**

Misura/size: Ø 70 h 42 cm



## FLORA LARGE

**COD. 161**

Misura/size: Ø 110 h 51 cm

FONTANINA non inclusa - not included



## ROMANTICA

**COD. 152**

Misura/size: Ø 80 h 70 cm

Piatti/plates: 5 x Ø 26 - 5 x Ø 20 -  
1 x Ø 34 cm

Porzioni/portions: 100/110



## SEMIRAMIDE

**COD. 153**

Misura/size: 100 x 54 h 88 cm

Piatti/plates: 3 x Ø 32 - 3 x Ø 26 -  
1 x Ø 38 cm

Porzioni/portions: 90/100



## MANHATTAN

**COD. 159**

Misura/size: Ø 65 h 85 cm

Piatti/plates: 6 x Ø 26 - 1 x Ø 38 cm

Porzioni/portions: 100/110



## STAIRWAY

**COD. 150**

Misura/size: h 80 cm

Piatti/plates: 23 x 18 - 29 x 17 - 39 x 19 -  
50 x 22 - 60 x 25 cm

Porzioni/portions: 75/85



## CLOVER

**COD. 188** - Misura/size: 65 x 62 h 38 cm  
Piatti/plates: 3 x Ø 28 - 3 x Ø 20 - 1 x Ø 22 cm  
Porzioni/portions: 40/50



## DAISY

**COD. 180** - Misura/size: Ø 90 h 45 cm  
Piatti/plates: 6 x Ø 28 - 1 x Ø 48 - 1 x Ø 30 cm  
Porzioni/portions: 120/130



## MEMPHIS

**COD. 183** - Misura/size: Ø 70 h 50 cm  
Porzioni/portions: 50/60



## MILANO

**COD. 192** - Misura/size: 62 x 62 h 38 cm  
Piatti/plates: 4 x Ø 20 - 1 x Ø 25  
Porzioni/portions: 30/35



## GRADUS

**COD. 190** - Misura/size: 88 x 30 h 43 cm  
Piatti/plates: Ø 20 - 22 - 24 - 26 - 28 cm  
Porzioni/portions: 45/55



## CONE

**COD. 185** - Misura/size: Ø 62 h 50 cm  
**COD. 184** - Misura/size: Ø 52 h 40 cm



## ENGLISH

**COD. 155**

Misura/size: h 65 cm

Piatti/plates: Ø 68 - 48 - 28 cm

Porzioni/portions: 60/70



## ENGLISH COLUMN

**COD. 158**

Misura/size: h 105 cm

Piatti/plates: Ø 68 - 48 - 28 cm

Porzioni/portions: 105/115



## CIRCLE

**COD. 104**

Misura/size: h 86 cm

Piatti/plates: Ø 25 - 30 - 35 - 40 - 48 cm

Porzioni/portions: 100/110



## CIRCLE

**COD. 103**

Misura/size: h 120 cm

Piatti/plates: Ø 25 - 30 - 35 - 40 - 48 cm

Porzioni/portions: 100/110

FONTANINA non inclusa - not included



## CARRÈ

**COD. 102**

Misura/size: h 96 cm

Piatti/plates: 25 x 25 - 30 x 30 - 35 x 35 -  
40 x 40 - 45 x 45 cm

Porzioni/portions: 145/155



## CARRÈ

**COD. 101**

Misura/size: h 120 cm

Piatti/plates: 25 x 25 - 30 x 30 - 35 x 35 -  
40 x 40 - 45 x 45 cm

Porzioni/portions: 145/155

FONTANINA non inclusa - not included

## ACCESSORI - ACCESSORIES



### Small column

**COLONNINA**

Misura/size: h 13 cm



### Big column

**COLONNA**

Misura/size: h 35 cm



### Electric fountain

**FONTANINA**

Misura/size: Ø 38 h 40 cm

# PLASTIC DUMMIES



Tamburi in plastica. Ideali per realizzare wedding cake di grandi dimensioni.  
Plastic cake dummies. Ideal for creating large wedding cakes.

## Tamburi - Dummies

Size cm	Codice - Code
h 10 - Ø20	40-W110
h 10 - Ø30	40-W111
h 10 - Ø40	40-W112
h 10 - Ø50	40-W113

## Set 4 tamburi- Set 4 dummies

**40-W106**

Misura/size: Ø 50- 40 - 30 - 20 cm



## Cerchi inox per tamburi St steel rings for dummies

Size cm	Codice - Code
h 5 - Ø19,5	40-W087
h 5 - Ø29,5	40-W088
h 5 - Ø39,5	40-W089
h 5 - Ø49,5	40-W090



## Piatto antiscivolo- Non-slip plate

**40-W124**

Misura/size: Ø58 cm



## Pioli per torta - Cake dowel rods

**40-W101**

Misura/size: Ø6 mm

Pack 50 pcs



## Pioli per torta - Cake dowel rods

**40PIO1**

Misura/size: Ø 16 h 300 mm

Pack 12 pcs



## Kit taglia pioli - Cutter kit

**40KITO1**

Pioli, seghetto e dima

Plastic dowel rods, hacksaw and support



**Tonda - Round**

**COD. 201**

Misura/size: Ø 49 h 58 cm

Piatti/plates: Ø 49 - 33 - 17 cm



**Ovale - Oval**

**COD. 202**

Misura/size: 51 x 41 h 58 cm

Piatti/plates: 51 x 41 - 35 x 25,5 - 19,5 x 10 cm



**Rettangolare - Rectangular**

**COD. 203**

Misura/size: 50 x 41 h 58 cm

Piatti/plates: 50 x 41 - 35 x 25 - 19 x 9 cm



**Quadrata - Square**

**COD. 204**

Misura/size: 49 x 49 h 58 cm

Piatti/plates: 49 x 49 - 33 x 33 - 17 x 17 cm

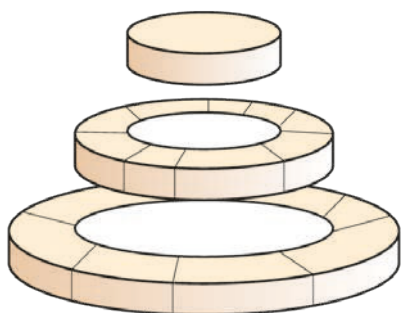

Preparare la base del pan di spagna da sagomare con l'aiuto dei piatti in plastica in dotazione in ogni Little Wedding Cake.

Prepare the sponge cake base to be shaped by using the plastic plates supplied with every Little Wedding Cake.

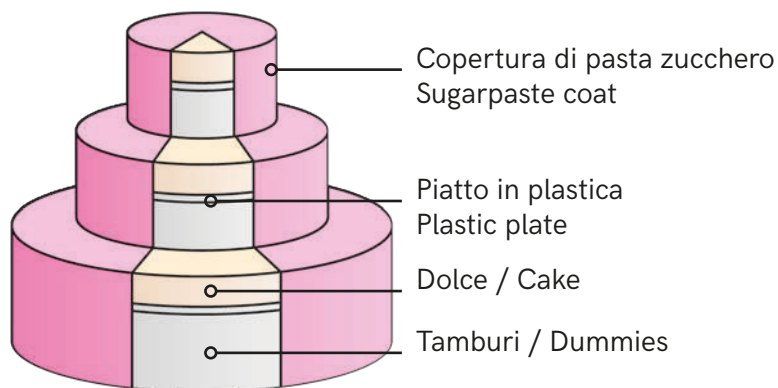

Copertura di pasta zucchero  
Sugarpaste coat

Piatto in plastica  
Plastic plate

Dolce / Cake

Tamburi / Dummies

## MULTIPIANO - MULTI-LEVEL



plastic

metal

Alzate multipiano disponibili nella versione in metallo (METAL) e in resistente plastica bianca (PLASTIC).

Multi level cake stands available in metal version (METAL) or in resistant white plastic (PLASTIC).

Misura Size cm	Porzioni Portions	Piani Levels	Code METAL	Code PLASTIC
Ø 20 - 26 - 32	34-36	3	METAL3	80-2003
Ø 20 - 26 - 32 - 40	60-62	4	METAL4	80-2004
Ø 20 - 26 - 32 - 40 - 45	90-92	5	METAL5	80-2005
Ø 20 - 26 - 32 - 40 - 45 - 50	130-132	6	METAL6	80-2006
Ø 16 - 20 - 26 - 32 - 40 - 45 - 50	175-180	7	METAL7	80-2007
Ø 16 - 20 - 26 - 32 - 40 - 45 - 50 - 55	220-225	8	METAL8	80-2008

# MACARON DISPLAYS



I display 80DM02 e 80DM03 sono tra loro impilabili per una maggiore capienza.  
The 80DM02 and 80DM03 displays are stackable with each other for greater capacity.



**MACARON 24**  
**80DM01** - pack 5 displays  
Ø 180 x 175 mm  
cap. 24 pcs



**MACARON 36**  
**80DM02**  
Ø 245 x 230 mm  
cap. 36 pcs

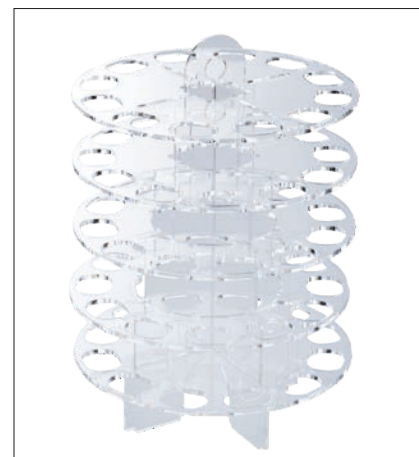

**MACARON 60**  
**80DM03**  
Ø 245 x 355 mm  
cap. 60 pcs



**AG05701**

460 x 330 h 145 mm - 7 file / rows  
cap. 70 pcs approx



**AG05601**

270 x 330 h 145 mm - 4 file / rows  
cap. 70 pcs approx



**AG05801**

315 x 325 h 65 mm - 5 file / rows  
cap. 50 pcs approx



**AG07901**

350 x 350 h 450 mm  
cap. 60 pcs



**AG07701P**

Ø 240 h 280 mm  
cap. 30 pcs



**AG07701**

Ø 280 h 430 mm  
cap. 62 pcs

# PLEXIGLASS SHOW CASES





**Vetrina porta brioche o macarons**  
**Showcase for croissants or macarons**  
**AG05820 - Trasparente/clear**  
 Misura/size: 32,5 x 35 h 13 cm  
 1 cassetto/drawer  
 Kit composto da vetrina, vassoio 30 x 32,5 cm e 5 binari 4 x 4 x 32 cm cad.  
 Kit consisting of display case, tray 30 x 32,5 cm and 5 rails 4 x 4 x 32 cm each.



**Vetrina con porta - Display with door**  
 Misura/size: 60 x 36 cm h 16 cm  
**VP00101 - Trasparente/clear**



**Vetrina con porta - Display with door**  
 Misura/size: 49,5 x 37,5 h 52 cm  
 2 ripiani/shelves  
**VB00908 - Nero/black**  
**VB00904 - Rosso/red**



**Vetrina con porta - Display with door**  
 Misura/size: 49,5 x 37,5 h 42,5 cm  
 3 ripiani inclinati/inclined shelves 39,5 x 27,5 cm  
**VB00208 - Nero/black**  
**VB00201 - Trasparente/clear**



**Vetrina a LED con porta - LED display with door**  
 Misura/size: 39,5 x 32,5 h 50,5 cm  
 3 ripiani inclinati/inclined shelves  
**VB00308 - Nero/black**



**Vetrina con porta - Display with door**  
 Misura/size: 31,5 x 30,5 h 45 cm  
 3 ripiani/shelves 39,5 x 27,5 cm  
**VB00804 - Trasparente/clear**



**Vetrina con porta - Display with door**  
 Misura/size: 41 x 36,5 h 44 cm  
 3 ripiani inclinati/inclined shelves  
**VB00306 - Trasparente/clear**



**Vetrina con porta - Display with door**  
 Misura/size: 37 x 31 h 31 cm  
 3 ripiani inclinati/inclined shelves  
**VB00408 - Nero/black**



**Vetrina con porta**

**Display with door**

Misura/size: 49,5 x 31 h 27 cm  
2 ripiani/shelves - 1 lato aperto/  
open side - 2 cassetti/drawers  
**AR02801** - Trasparente/clear



**Vetrina con 2 porte**

**Display with 2 doors**

Misura/size: 50 x 38 h 45,5 cm  
2 ripiani/shelves  
**VB00501** - Trasparente/clear



**Vetrina con 4 porte**

**Display with 4 doors**

Misura/size: 60 x 37 h 40 cm  
2 ripiani/shelves  
**VB00102** - Trasparente/clear

---

## PROTEGGI BRIOCHE - FOOD SHIELD

Misure personalizzabili su richiesta - Measures can be changed on request



**Proteggi brioche - Plexiglass food shields**

**AR0001** - 49,5 x 30 h 27 cm  
**AR00011** - 99,5 x 30 h 27 cm



**Proteggi brioche con battuta 4 cm**  
**Plexiglass food shields with 4 cm batting**

**AR0001B** - 49,5 x 30 h 27 cm  
**AR00011B** - 99,5 x 30 h 27 cm

## PLEXIGLASS PLATES



**Vassoi bianchi con bordi, ideali per brioche**  
**White trays with edges, ideal for croissants**

**51VP024510** - 45 x 10 h 2,5 cm

**51VP024515** - 45 x 15 h 2,5 cm

**51VP024525** - 45 x 25 h 2,5 cm

**51VP026010** - 60 x 10 h 2,5 cm

**51VP026015** - 60 x 15 h 2,5 cm

**51VP026025** - 60 x 25 h 2,5 cm



**Vassoi bianchi piani, ideali per monoporzioni,**  
**mignon e pralineria / White flat trays, ideal for**  
**monoportions, mignon and pralines**

**51VP014510** - 45 x 10 cm

**51VP014515** - 45 x 15 cm

**51VP014525** - 45 x 25 cm

**51VP016010** - 60 x 10 cm

**51VP016015** - 60 x 15 cm

**51VP016025** - 60 x 25 cm



# PLEXIGLASS PLATES

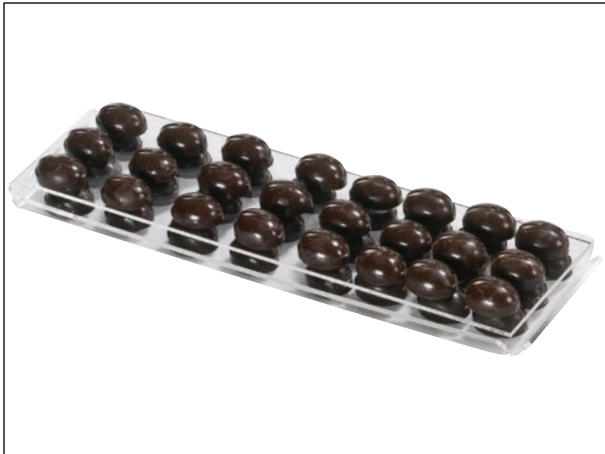

**Vassoio per vetrina con bordi**  
**Display tray with edges**

**VP00401** - 34 x 11 h 2 cm

**Piatto per vetrina**

**Display plate**

**VP00501** - 32 x 9 h 0,2 cm



**Vassoio per vetrina con bordi**  
**Display tray with edges**

**VP00906** - 10 x 50 h 2 cm

**Piatto per vetrina**

**Display plate**

**VP01001** - 9,5 x 49,5 h 0,2 cm



**Vassoio per vetrina con bordi - bianco**  
**Display tray with edges - white**

**VP00500** - 32 x 20 h 2,5 cm

**VP00700** - 18 x 29 h 2,5 cm

**50VP00402** - 14 x 40 h 2 cm

**Piatto per vetrina - trasparente**

**Display plate - clear**

**VP00601** - 26 x 15 h 0,2 cm

**VP00801** - 13 x 24 h 0,2 cm



**Vassoio per vetrina con bordi - satinato**  
**Display tray with edges - glazed**

**VP01106** - 17 x 23 h 2 cm

**VP00206** - 17 x 17 h 2 cm

**Piatto per vetrina - trasparente**

**Display plate - clear**

**VP01201** - 16,5 x 22,5 h 0,2 cm

**VP00301** - 16,5 x 16,5 h 0,2 cm

# PLEXIGLASS PLATES



## Vassoi neri con bordi / Black trays with edges

- 50VP0508 - 14,5 x 40 h 2 cm
- 50VP0608 - 14,5 x 28,9 h 2 cm
- 50VP0708 - 20,4 x 25,8 h 2 cm
- 50VP0808 - 29,4 x 39,4 h 2 cm



## Vassoi bianchi con bordi / White trays with edges

- 50VP0500 - 14,5 x 40 h 2 cm
- 50VP0600 - 14,5 x 28,9 h 2 cm
- 50VP0700 - 20,4 x 25,8 h 2 cm
- 50VP0800 - 29,4 x 39,4 h 2 cm



## Vassoi neri piani quadrati, spessore 5 mm Black flat square trays , thickness 5 mm

- 50VP202008 - 20 x 20 cm
- 50VP252508 - 25 x 25 cm

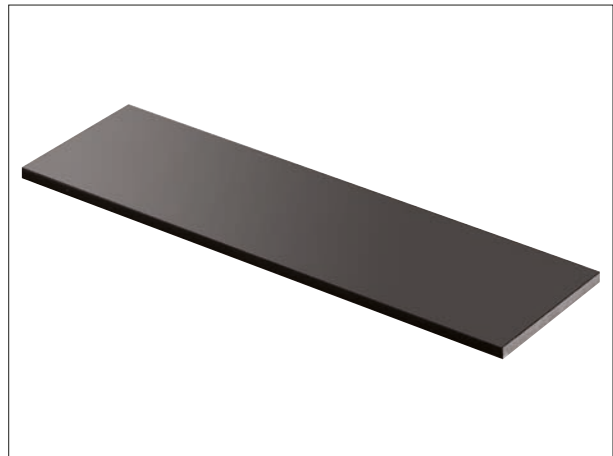

## Vassoi neri piani rettngolari, spessore 5 mm Black flat rectangular trays , thickness 5 mm

- 50VP201008 - 20 x 10 cm
- 50VP251208 - 25 x 12 cm
- 50VP601008 - 60 x 10 cm
- 50VP602508 - 60 x 25 cm



Su richiesta ampia gamma di colori e misure  
On request different colors and sizes

# MULTI ICE revolution

Stampi in speciale materiale plastico per realizzare splendide sculture in ghiaccio.  
Moulds made of special plastic to create spectacular ice sculptures.



## MIR01

scultura/sculpture: 42 x 26 h 53 cm  
stampo/mould: 60 x 25 h 65 cm - 7 kg



## MIR08

scultura/sculpture: 58 x 25 h 56 cm  
stampo/mould: 69 x 25 h 70 cm - 8 kg



## MIR07

scultura/sculpture: 41 x 41 h 83 cm  
stampo/mould: 51 x 41 h 96 cm - 9 kg



## MIR17

scultura/sculpture: Ø 39 h 15 cm  
stampo/mould: Ø 53 h 19 cm - 4,5 kg



## MIR16

scultura/sculpture: Ø 40 h 20 cm  
stampo/mould: Ø 52 h 23 cm - 4 kg



## MIR05

scultura/sculpture: 36 x 26 h 67 cm  
stampo/mould: 50 x 26 h 78 cm - 7,5 kg



## MIP - pompetta/pump

La pompetta tiene in movimento l'acqua all'interno dello stampo durante il processo di congelazione e la scultura di ghiaccio risulterà più trasparente.

The air pump makes the water circulate inside the mould during the process of freezing and the ice sculpture will be more transparent.



## Supporto per pompetta Air pump support

MIS05 - per MIR05

MIS08 - per MIR08



# CREATIVE COLORS

# Velvet SPRAY

Spray a base di burro di cacao che dona un effetto vellutato. L'articolo deve essere spruzzato su tutte le superfici fredde come gelato, semifreddi, mousse e cioccolato, perchè il burro di cacao cristallizzi creando l'effetto desiderato.

*Spray cocoa butter with a velvety effect. The article can be sprayed on all cold surfaces such as ice cream, semifreddo, mousse and chocolate.*



 WHITE  
**40LCV000**  
400 ML



 ORANGE  
**40LCV001**  
400 ML

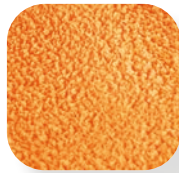

 SKY BLUE  
**40LCV003**  
400 ML



 YELLOW  
**40LCV004**  
400 ML



 MILK CHOCOLATE  
**40LCV005**  
400 ML



 BLACK  
**40LCV006**  
400 ML

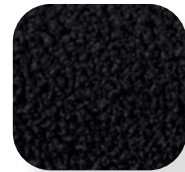

 PINK  
**40LCV007**  
400 ML



 RED  
**40LCV008**  
400 ML



 GREEN  
**40LCV009**  
400 ML



 LILAC  
**40LCV010**  
400 ML

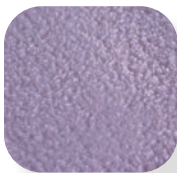

 BLACK CHERRY RED  
**40LCV013**  
400 ML



 DARK CHOCOLATE  
**40LCV015**  
400 ML



 WHITE CHOCOLATE  
**40LCV024**  
400 ML



 FUCHSIA  
**40LCV027**  
400 ML



# COLOR DUST

**WATER-SOLUBLE**

*Food Coloring Powder*

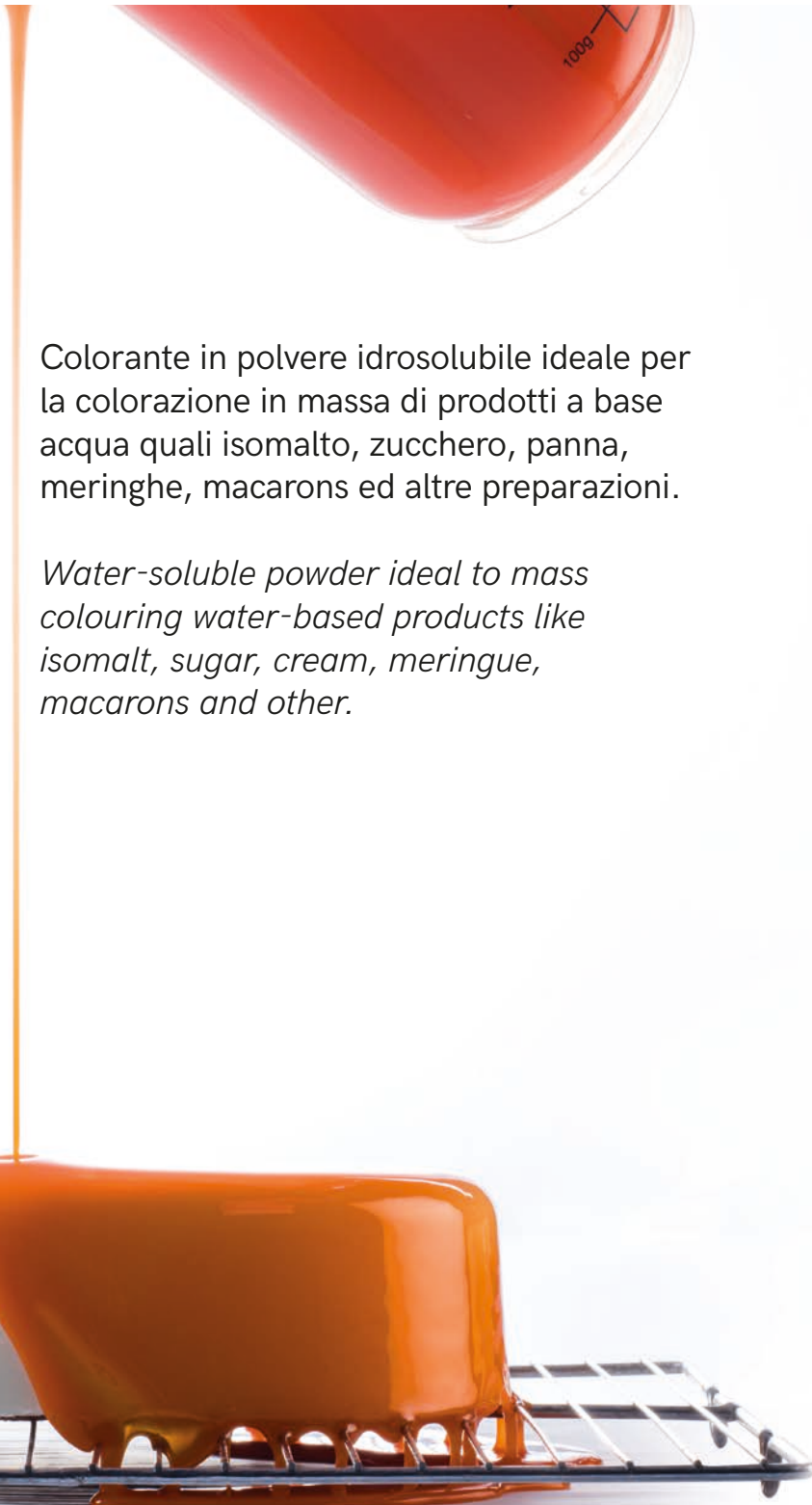

Colorante in polvere idrosolubile ideale per la colorazione in massa di prodotti a base acqua quali isomalto, zucchero, panna, meringhe, macarons ed altre preparazioni.

*Water-soluble powder ideal to mass colouring water-based products like isomalt, sugar, cream, meringue, macarons and other.*

 BLUE  
40LCP202 25 GR

 E171  
FREE



 YELLOW  
40LCP204 25 GR

 E171  
FREE



 BLACK  
40LCP206 25 GR

 E171  
FREE



 RED  
40LCP208 25 GR

 E171  
FREE

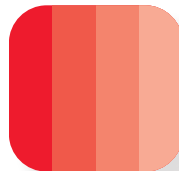

 GREEN  
40LCP209 25 GR

 E171  
FREE



 ORANGE  
40LCP211 25 GR

 E171  
FREE

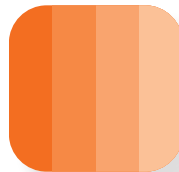

 STRAWBERRY RED  
40LCP218 25 GR

 E171  
FREE

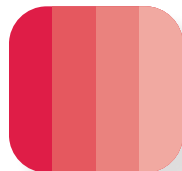

 TURQUOISE  
40LCP226 25 GR

 E171  
FREE



# COLOR DUST

## LIPOSOLUBLE

*Food Coloring Powder*



Colorante in polvere liposolubile adatto alla colorazione in massa di prodotti a base grassa quali cioccolato, crema al burro, pasta di mandorle, pasta da zucchero, semifreddi.

Può essere utilizzato in superficie con un pennello tal quale o diluito con la nostra gommalacca liquida per ottenere un prodotto per la decorazione a pennello.

*Fat-soluble powder colour appropriate for in mass colouring of fat based products like chocolate, butter cream, almond paste, sugar paste, semifreddo. You could use it as such on product surface using a brush or you can dilute it using our liquid shiny obtaining a product for decoration by brush.*



# PEARL

# PASTEL

 PEARL COBALT  
**40LCP002** 25 GR

 **40WC002** 5 GR

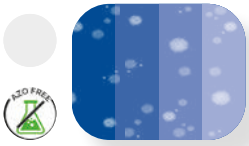

 PEARL VIOLET  
**40LCP010** 25 GR

 **40WC010** 5 GR



 WHITE  
**40LCP300** 25 GR





 BLUE  
**40LCP302** 25 GR

 **40WC302** 5 GR

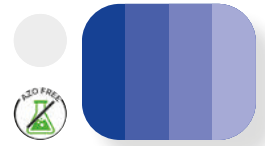

 PEARL BRONZE  
**40LCP015** 25 GR

 **40WC015** 5 GR

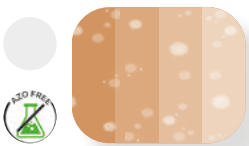

 PEARL LIME GREEN  
**40LCP016** 25 GR

 **40WC016** 5 GR

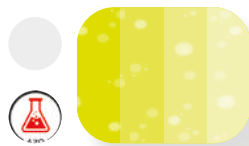

 YELLOW  
**40LCP304** 25 GR

 **40WC304** 5 GR

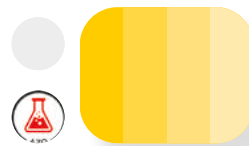

 BROWN  
**40LCP305** 20 GR

 **40WC305** 5 GR

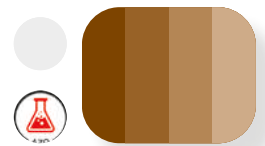

 PEARL GOLD  
**40LCP017** 25 GR

 **40WC017** 5 GR

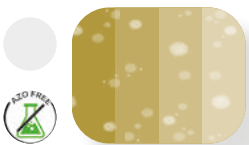

 PEARL RUBY  
**40LCP018** 25 GR

 **40WC018** 5 GR

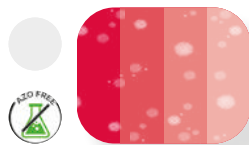

 BLACK  
**40LCP306** 25 GR

 **40WC306** 5 GR

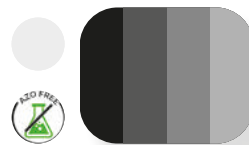

 PINK  
**40LCP307** 25 GR

 **40WC307** 5 GR

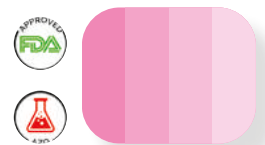

 DARK PEARL SILVER  
**40LCP019** 25 GR

 **40WC019** 5 GR

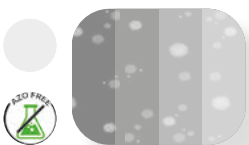

 PEARL COPPER  
**40LCP020** 25 GR

 **40WC020** 5 GR

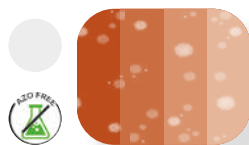

 RED  
**40LCP308** 25 GR

 **40WC308** 5 GR

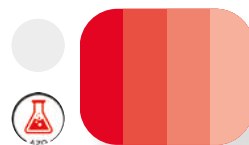

 SHOCK RED  
**40LCP308N** 25 GR

 **40WC308N** 5 GR

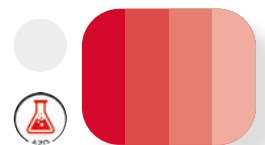

 LIGHT PEARL SILVER  
**40LCP119** 25 GR

 **40WC119** 5 GR



 GREEN  
**40LCP309** 25 GR

 **40WC309** 5 GR



 ORANGE  
**40LCP311** 25 GR

 **40WC311** 5 GR



 TURQUOISE  
**40LCP326** 25 GR

 **40WC326** 5 GR



# Natural COLOR



Colorante alimentare naturale in polvere idrosolubile ideale per la decorazione e colorazione di meringhe, macaron, glasse e molto altro.

*Water-soluble natural food coloring powder ideal for the decoration and coloring of meringues, macaron, glaze and much more.*



 BLUE  
40LCPN202 25 GR



 YELLOW  
40LCPN204 25 GR



 BLACK  
40LCPN206 25 GR

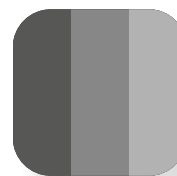

 RED  
40LCPN208 25 GR

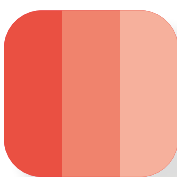

 GREEN  
40LCPN209 25 GR



# Natural COLOR



Colorante alimentare naturale in polvere liposolubile adatto alla colorazione in massa di prodotti a base grassa quali cioccolato, crema al burro, pasta di mandorle, pasta da zucchero, semifreddi.

*Edible natural dye. Liposoluble powder colour suitable for the mass coloring of fat-based products such as chocolate, butter cream, almond paste, sugar paste, semifreddo.*

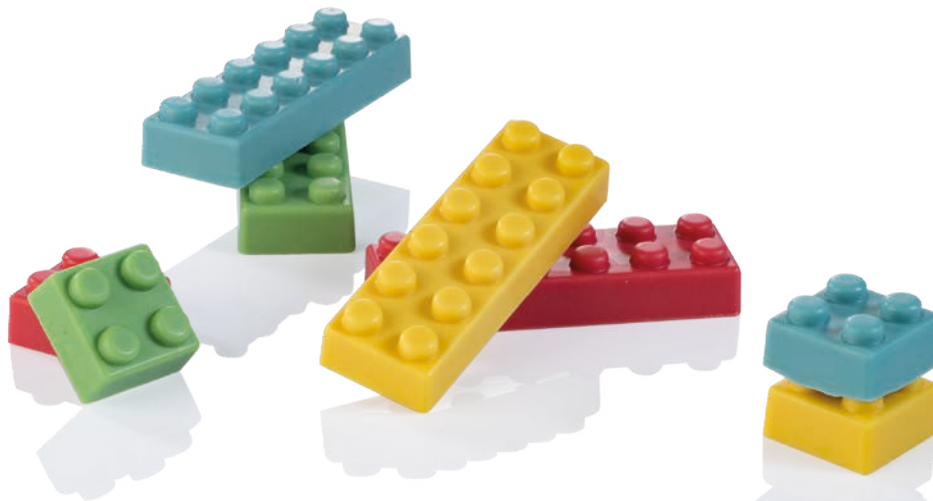

 **BLUE**  
**40LCPN302** 25 GR



 **YELLOW**  
**40LCPN304** 25 GR

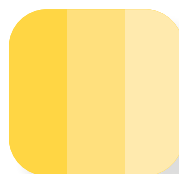

 **PINK**  
**40LCPN307** 25 GR



 **RED**  
**40LCPN308** 25 GR

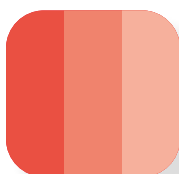

 **GREEN**  
**40LCPN309** 25 GR

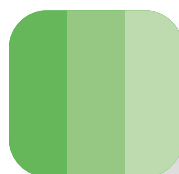

 **VIOLET**  
**40LCPN310** 25 GR



# Metal DUST

Colorante in fine polvere con effetto perlato ideale per decorare prodotti finiti, presentato con speciale packaging spray non pressurizzato.

*Soft powder colour with a pearly effect in a special non-pressurized spray packaging.*



SPARKLING PEARL  
RED



**40LCP508**  
10 GR

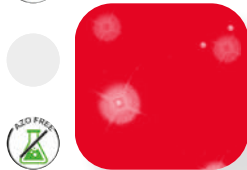

SPARKLING PEARL  
CHERRY RED



**40LCP513**  
10 GR

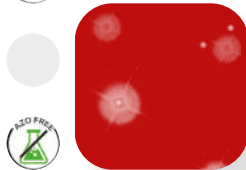

SPARKLING PEARL  
BRONZE



**40LCP515**  
8 GR

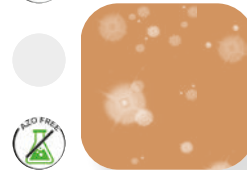

SPARKLING PEARL  
GOLD



**40LCP517**  
10 GR

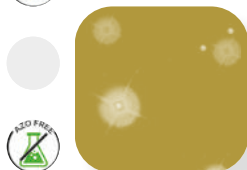

SPARKLING PEARL  
SILVER



**40LCP519**  
10 GR



SPARKLING PEARL  
COPPER



**40LCP520**  
10 GR

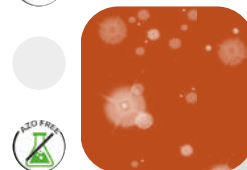

# DRIP Top

Prodotto di facile utilizzo per decorare tramite la tecnica del dripping torte, semifreddi, gelati e molto altro.

*Product easy to use to decorate cakes using the dripping technique, frozen desserts, ice cream and much more.*



 BLUE  
**40LCD003**  
180 GR



 CHOCOLATE  
**40LCD005**  
180 GR

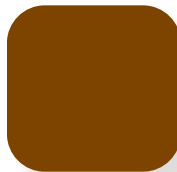

 PINK  
**40LCD007**  
180 GR



 CHERRY RED  
**40LCD008**  
180 GR



 WHITE CHOCOLATE  
**40LCD024**  
180 GR

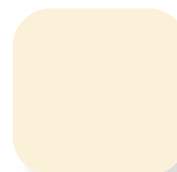

# color SMART



Spray colorati idroalcolici ideali per decorare torte a base di panna, piccole decorazioni di cioccolato, prodotti di pasticceria come biscotti, wafer, cialde e dolci a base di pasta di zucchero.

*Colored hydroalcoholic sprays ideal for decorating cream-based cakes, small chocolate decorations, pastry products such as biscuits, wafers, waffles and sugar paste covered cakes.*

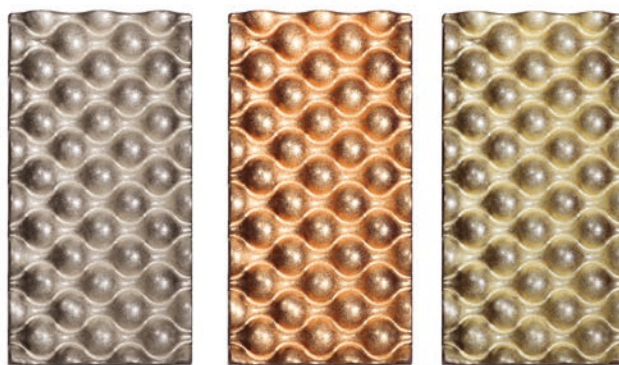

# PEARL

# PASTEL

 PEARL MOTHER  
OF PEARL  
**40LCS200** 100 ML



 PEARL BRONZE  
**40LCS215** 100 ML

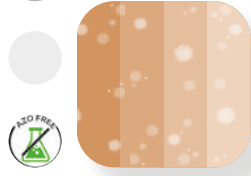

 WHITE  
**40LCS000** 100 ML



 ORANGE  
**40LCS001** 100 ML

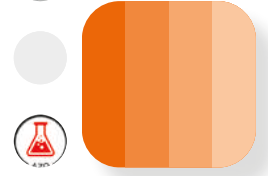

 PEARL GOLD  
**40LCS217** 100 ML



 PEARL RUBY  
**40LCS218** 100 ML

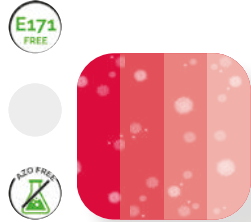

 YELLOW  
**40LCS004** 100 ML



 BROWN  
**40LCS005** 100 ML



 PEARL SILVER  
**40LCS219** 100 ML



 PEARL COPPER  
**40LCS220** 100 ML

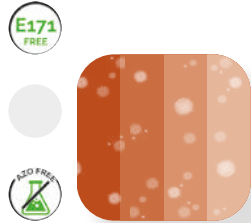

 PINK  
**40LCS007** 100 ML



 RED  
**40LCS008** 100 ML



 GREEN  
**40LCS009** 100 ML



# gel COLOR



Colorante in gel idrosolubile molto concentrato nato per la colorazione in massa di tutti i prodotti a base acqua o emulsioni come pasta di zucchero, panna, crema al burro, glassa, impasti vari quali biscotti meringhe e torte.

*Very concentrated water-soluble gel colour created for the mass coloring of all water-based products or emulsions such as sugar paste, cream, butter cream, icing, various doughs such as meringue biscuits and cakes.*



 ORANGE  
40LCG001 30 GR

 E171  
FREE

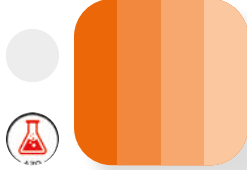

 BLUE  
40LCG002 30 GR

 E171  
FREE

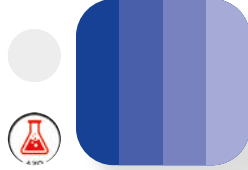

 YELLOW  
40LCG004 30 GR

 E171  
FREE

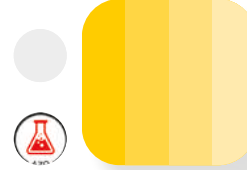

 BROWN  
40LCG005 30 GR

 E171  
FREE

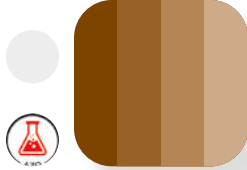

 BLACK  
40LCG006 30 GR

 E171  
FREE

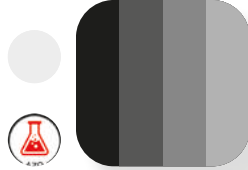

 PINK  
40LCG007 30 GR

 E171  
FREE



 RED  
40LCG008 30 GR

 E171  
FREE

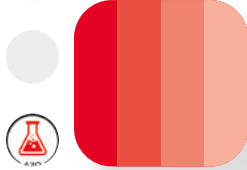

 GREEN  
40LCG009 30 GR

 E171  
FREE



 VIOLET  
40LCG010 30 GR

 E171  
FREE



 LIME GREEN  
40LCG016 30 GR

 E171  
FREE



 TURQUOISE  
40LCG026 30 GR

 E171  
FREE



# EASY COLOR



Colorante liquido pronto all'uso, pensato per assicurare una nebulizzazione perfetta ed omogenea sulla superficie di torte e dolci attraverso l'utilizzo di aerografi.

Grazie alla sua formula idrosolubile, è ideale anche per la colorazione in massa di pan di spagna, panna, crema, gelatina, pasta di mandorle, marzipane e bevande in genere.

*Ready-to-use liquid colour, designed to ensure a perfect and homogeneous nebulization on the surface of cakes and sweets through the use of airbrushes.*

*Thanks to its water-soluble formula, it is also ideal for the mass coloring of sponge cake cream, cream, jelly, almond paste, marzipan and drinks in general.*



 ORANGE  
40LCA001 190 ML

 E171  
FREE

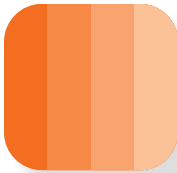

 BLUE  
40LCA002 190 ML

 E171  
FREE



 SKY BLUE  
40LCA003 190 ML

 E171  
FREE

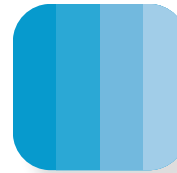

 YELLOW  
40LCA004 190 ML

 E171  
FREE



 BROWN  
40LCA005 190 ML

 E171  
FREE

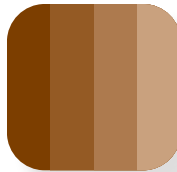

 BLACK  
40LCA006 190 ML

 E171  
FREE

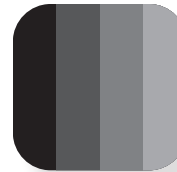

 PINK  
40LCA007 190 ML

 E171  
FREE



 RED  
40LCA008 190 ML

 E171  
FREE



 GREEN  
40LCA009 190 ML

 E171  
FREE

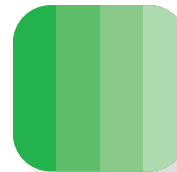

 VIOLET  
40LCA010 190 ML

 E171  
FREE



 LEMON YELLOW  
40LCA011 190 ML

 E171  
FREE



 LIGHT GREEN  
40LCA012 190 ML

 E171  
FREE



# CHOCOLOR

Food Coloring Cocoa Butter



Burro di cacao colorato, ideale per la colorazione e decorazione di cioccolato e masse grasse.

*Coloured cocoa butter, perfect to colour and decorate chocolate and fat masses.*



 **WHITE**  
**40LCB000** 200 GR



 **ORANGE**  
**40LCB001** 200 GR

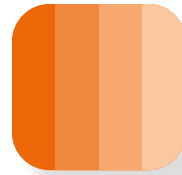

 **BLUE**  
**40LCB002** 200 GR



 **YELLOW**  
**40LCB004** 200 GR



 **BLACK**  
**40LCB006** 200 GR

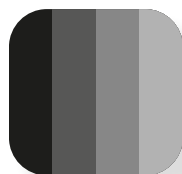

 **RED**  
**40LCB008** 200 GR

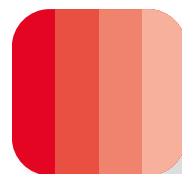

 **GREEN**  
**40LCB009** 200 GR

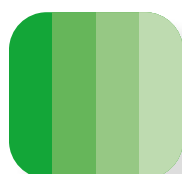

 **GOLD**  
**40LCB017** 200 GR

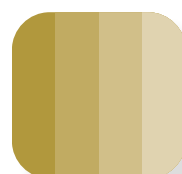

 **SILVER**  
**40LCB019** 200 GR



# Butter SPRAY

40LCV100  
400 ML



Lucidante alimentare neutro a base di burro di cacao ideale per proteggere e lucidare marzapane e pasta di mandorle.

*Neutral food polish made of cocoa butter ideal for protecting and polishing marzipan and almond paste.*

# Baking SPRAY

COATING  
400 ML



Staccante alimentare per velocizzare la rimozione del prodotto da teglie in acciaio e alluminio, stampi, termoformati o altro. Inodore e insapore.

*Ideal food release agent to speed up the removal of the product from steel and aluminium trays, moulds, thermoformed or other. Odorless and tasteless.*

# Shiny SPRAY

40LCS201  
300 ML



Gommalacca spray ideale per lucidare e proteggere superfici a base di zucchero e cioccolato.

*Shellac spray ideal for polishing and protecting sugar and chocolate surfaces.*

# Cooling SPRAY

EUROCHOCK  
400 ML



Refrigerante spray per raffreddamento istantaneo di prodotti a base di zucchero o cioccolato durante la lavorazione artistica.

*Spray cooler for instant chilling of sugar or chocolate products during the artistic processing.*

# JELLIES

Gelatina alimentare ideale per guarnire torte e prodotti di pasticceria in genere, può essere colorata con i gel color e con le polveri idrosolubili.

*Food-grade gelatine ideal for garnishing cakes and pastry products in general, it can be coloured with colourant gels and water-soluble powders.*



JELLIES - FOOD JELLY  
**40LCJ000**  
1 KG



# GLUE



Colla alimentare per la creazione di soggetti in pasta di zucchero e cialda.

*Food glue for the creation of sugar paste and wafer subjects.*

GLUE - FOOD GLUE

**40W166**  
25 GR



# CMC



Additivo alimentare utilizzato come addensante. Aggiungendolo alla pasta zucchero si ottiene una pasta più resistente e più facile da modellare.

*Food additive used as thickener. By adding it to the sugar paste it produces a more resistant and easier to shape paste.*

CMC - THICKENER FOR SUGAR

**40W042**  
40 GR



# INDICE ALFABETICO

## ITALIANO

Descrizione	Pag
ACETATI	260
ADATTATORI BOCCHETTE	351
AEROGRAFI	410
AGHI PANETTONE	247
ALZATE TORTA	448
BICCHIERINI E COPPETTE	420
BILANCE	331
BOCCHETTE	344
CAKE DESIGN	402
CAKE IDEA	248
CANNELLI	401
CANNOLI	374
CAPPELLI	393
CARAFFE	388
CARAMELLOMETRO	401
CARTA FORNO	376
CESTINI PANE	391
CHABLON DECORATIVI	104
CHITARRE	310
CIOTOLE	389
COLINI	329
COLORANTI ALIMENTARI	478
COLTELLI	364
COMUNIONE, CRESIMA	176
CONTENITORI IN PLEXIGLASS	287
COPERCHI	326
DECORO CROSTATE, STAMPO	357
DESSERT IDEA	262
DIME	298/372/385
ESPOSITORI FINGER FOOD	434
ESPOSITORI MACARON	468

Descrizione	Pag
FASCE INOX	231
FLACONI	384
FONTANE PER CIOCCOLATO	192
FORCHETTINE PER CIOCCO	184
FRUSTE	359
GELATI, STAMPI	272
GELATINE, STAMPI	227
GHIACCIOLI, STAMPI	270
GIRATORTA	324
GRATTUGIE / ZESTER	365
GRIGLIE	367
GRIGNOTTINA	330
GUANTI	394
HALLOWEEN, STAMPI	48/162/178
LAMPADA DA ZUCCHERO	400
LEVEL, STENDI IMPASTO	301
LIRA	375
LOLLIPOP	179
MART CUTTER, TAGLIANASTRI	306
MATRIMONIO, STAMPO SILICONE	174
MICROFORATI	200
MIGNON	255
MONOPORZIONI	254
NAPOLITAIN	80
NASCITE E BATTESIMI	174
NATALE	115
NUMERI	249/407
ONE STRIP STAMPO SEMIFREDDO	208
PACKAGING	185
PALA PER DOLCI	324

Descrizione	Pag
PALLINATORE	294
PANDORI, STAMPO	247
PANE, STAMPI	390
PENNELLI	366
PETTINI DECORATIVI	416
PIASTRA RISCALDANTE	304
PIATTINI	431
PINZE	365
PORZIONATORI, GELATO	283
PRALINE	16
RAPLETTE	372
RASCHIETTI	363
RIFRATTOMETRO	330
RULLI	371
RULLI FORAPASTA	369
S. VALENTINO	46/90
SAC A POCHE	338
SCIOGLITORI	186
SCULTURE GHIACCIO	477
SEGNAGUSTO	284
SEGNAPREZZO	395
SEMIFREDDI, STAMPI	250
SEMISFERE	45
SESSOLE	389
SETACCI	367
SIFONI	328
SILICONE, STAMPI	212
SNACK	30/73
SOGGETTI IN CIOCCOLATO	108
SOTTOTORTA	397
SPATOLE	354
SPATOLE GELATO	282
SPAZZOLE	393
STAMPI PER ROTATIVA PERFORMANCE	164
STENCIL DECORO	411
STENDIPASTA	325

Descrizione	Pag
TAGLIA CROISSANT	370
TAGLIABISCOTTI	380
TAGLIAPASTA ESTENSIBILE	368
TAGLIERE	385
TAGLIERINI	392
TAMBURI PER TORTE	466
TAPPETI	387
TAPPETI DECORO	403
TAVOLE MULTIUSO	396
TAVOLETTE, STAMPI	53/59/67
TEGLIE	386
TELAI GANACHE	320
TELI LIEVITAZIONE	391
TERMOMETRI	331
TIMBRI	88
TORTIERE SILICONE	226
TRAVEL CAKE	196
TRONCHETTI	264
UOVA DI CIOCCOLATO	134
VASCHE TTE GELATO	280
VASSOI	327/474
VETRINE	470

# ALPHABETICAL INDEX

## ENGLISH

Description	Pag
ACETATE	260
AEROGRAPHERS	410
BAKING PAPER	376
BALL SHAPING MACHINE	294
BAR, MOULDS	53/59/67
BIRTHS AND BAPTISMS	174
BISCUIT CUTTER	380
BOWLS	389
BREAD BASKETS	391
BREAD, MOULDS	390
BRUSHES	366
BRUSHES	393
CAKE BOARDS	397
CAKE DESIGN	402
CAKE DRUMS	466
CAKE IDEA	248
CAKE LIFTER	324
CAKE SLICER	375
CAKE STANDS	448
CAKE TURNING ROD	247
CAKE TURNTABLES	324
CANNOLI	374
CARAFES	388
CARAMMELOMETER	401
CHOCOLATE 3D OBJECTS	108
CHOCOLATE EGGS	134
CHOCOLATE FORKS	184
CHOCOLATE FOUNTAINS	192
CHRISTMAS	115
COLOURANTS	478
COMMUNION, CONFIRMATION	176

Description	Pag
CROISSANT CUTTER	370
CUPS	420
CUTTERS	392
CUTTING BOARD	385
CUTTING DOCKERS	369
DECOR MATS	403
DECOR STENCIL	411
DECORATIVE CHABLONS	104
DECORATIVE COMBS	416
DESSERT IDEA	262
DOUGH PROOFING SHEET	391
EXTENDABLE PASTRY CUTTER	368
FINGER FOOD DISPLAYS	434
FLACONS	384
FLOUR SCOOPS	389
FUNNELS	329
GANACHE FRAMES	320
GLOVES	394
GRATERS / ZESTERS	365
GRIGNOTTINE	330
GUITARS	310
HALLOWEEN, MOULDS	48/162/178
HATS	393
ICE CREAM BASINS	280
ICE CREAM SPATULAS	282
ICE LOLLIES, MOULDS	270
ICE MARKERS	284
ICE SCULPTURES	477
ICE-CREAM, MOULDS	272
JELLIES, MOULDS	227
KNIVES	364

Description	Pag
LEVEL, DOUGH SPREADER	301
LIDS	326
LOG	264
LOLLIPOP	179
MACARON DISPLAYS	468
MART CUTTER	306
MATS	387
MELTERS	186
MICROFORATI	200
MIGNON	255
MONOPORTIONS	254
MULTIPURPOSE BOARDS	396
NAPOLITAIN	80
NOZZLE ADAPTERS	351
NUMBERS	249/407
ONE STRIP SEMIFREDDO MOULD	208
PACKAGING	185
PANDORO, MOULD	247
PASTRY BAGS	338
PINCERS	365
PIPING TIPS	344
PLATES	431
PLEXIGLASS CONTAINERS	287
PORTIONERS, ICE CREAM	283
PRALINE	16
PRICE MARKERS	395
RACKS	367
RAPLETTE	372
REFRACTOMETER	330
ROLLING MACHINE	325
ROLLING PINS	371
ROTATING MACHINES MOULDS PERFORMANCE	164
S. VALENTINE	46/90
SCALES	331

Description	Pag
SCRAPERS	363
SEMIFREDDO, MOULDS	250
SEMISPHERE	45
SHOWCASES	470
SIEVES	367
SILICONE CAKE PAN	226
SILICONE, MOULDS	212
SNACKS	30/73
SPATULAS	354
STAINLESS STEEL BANDS	231
STAMPS	88
SUGAR LAMP	400
TART DECORATIONS, MOULD	357
TEMPLATES	298/372/385
THERMOMETERS	331
TOCHES	401
TRAVEL CAKES	196
TRAYS	386
TRAYS	327/474
WARMING PLATE	304
WEDDING, SILICONE MOULD	174
WHIPPERS	328
WHISKS	359

# INDICE NUMERICO

# NUMERICAL INDEX

Cod.	Pag
104000 / 104001	275
104002 / 104003	273
105000 / 105003	277
10CG01 / 10CG04	283
10-E002	277
10E006 / 10E007	273 /275
10PG01 / 10PG05	283
10SA001B	285
10SEG / 10SEGB	284
10SEG05 / 10SEG06	284
10SG00 / 10SG100	282
10SGC00 / 10SGC100	282
10SI001B / 10SI002B	284
10SL072	273/275
10SL114	273/275
11H4L24 / 11H4L40	242
11H4L56 / 11H4L59	242
11H5L24 / 11H5L40	242
11H5L56 / 11H5L59	242
13H4X15 / 13H4X30	244
14H4X16 / 14H4X30	244
15H4X25 / 15H4X34	244
18H4X17 / 18H4X26	237
18H5X17 / 18H5X26	237

Cod.	Pag
1H25X14 / 1H25X24	203
1H25X14/ 1H25X24	239
1H2X8	203
1H2X8 / 1H2X28	239
1H35X14 / 1H35X24	203
1H35X14 / 1H35X24	239
1H3X10 / 1H3X18	239
1H4X8 / 1H4X30	239
1H5X10 / 1H5X30	238
1H6X6 / 1H6X28	238
20-1010	106
20-1011	106
203D01 / 203D04	167
20-3D1001 / 20-3D1003	38
20-3D2001	38
20-3D2002 / 20-3D2003	38
20-3D3001	38
20-3D4001	38
20-3D5001	38
20-3D6001	38
20A3D01 / 20A3D02	119
20BA01	130
20BC100	121
20-C024	179

Cod.	Pag
20-C1000	113
20-C1001	113
20-C1002	113
20-C1010	113
20-C1955 / 20-C1957	157
20CG01	126
20CO01 / 20CO02	118
20CT01	118
20-CU001	152
20-D001 / 20-D029	101/103
20-D015	77
20-D029	122
20EC01 / 20EC02	228
20FH01S / 20FH01L	93
20FH02S / 20FH02L	94
20FH03L	95
20FH03S	95
20FH04	93
20FH05	94
20FH06	95
20FH07S / 20FH07L	92
20FH30S / 20FH30L	89
20FH31S / 20FH31L	90
20FH32L	89
20FH33L	89
20FH34	89
20FH35L	91
20FH36S / 20FH36L	91
20FH37S / 20FH37L	90
20FH38L	91

Cod.	Pag
20FH50	97
20FH51	97
20FH52	99
20FH53	98
20FH54	98
20FRUIT01 / 05	38
20GU001 / 20GU006	85
20GU007 / 20GU009	84
20GU500 / 20GU502	84
20HO01	120
20L001 / 20L003	180
20L004	178
20L005	179
20L006	178
20L007 / 20L008	180
20OB01	128
20OR001	155
20PA01	130
20PC01	126
20PP01	129
20PR01	120
20S004 / 20S005	181
20SC01	161
20SF001 / 20SF002	45/ 122
20SF003 / 20SF008	123
20SI01	128
20SL01	120
20SR001 / 20SR004	147
20SR001A / 20SR004A	169
20SR020	137

Cod.	Pag
20SR020A	170
20SR021	136
20SR021A	170
20SR022	135
20SR022A	170
20SR100	111
20SR100A	172
20SR101	111
20SR101A	173
20SR102	112
20SR102A	173
20SR103	112
20SR103A	173
20TC001 / 20TC006	67
20TES001 / 20TES007	267
20U032N	149
20U064N	149
20-U1010 / 20-U1011	153
20U105N	149
20U130N	149
20U150N	149
20U175N	149
20U204N	149
20U227N	149
20U258	149
20U320	149
20U3D01	144
20U3D02 / 20U3D05	142/143
20U3D06	145
20U3D07 / 20U3D08	141

Cod.	Pag
20U500 / 20U501	140
20U502	138
20U503	138
20U504	139
20UB100	154
20WT01	127
22BOX48 / 22BOX48T4	185
22BOX60 / 22BOX60T4	185
22BOX85 / 22BOX85T4	185
23H4X25 / 23H4X35	243
23H5X25 / 23H5X35	243
27H4X12 / 27H4X16	244
29003	181
2H4X12 / 2H4X30	241
30BANDS01 / 30BANDS07	203
30CH001	247
30H4X01 / 30H4X10	246
30IDEA01 / 30IDEA06	263
30MICRO01 / 30MICRO11	206/207
30SF001 / 30SF006	218
30SF007 / 30SF009	220
30SF013 / 30SF024	220
30SF022 / 30SF024	219
30SF025 / 30SF026	221
30SF028 / 30SF029	220
30SF030	220
30SF031 / 30SF032	219
30SF033 / 30SF035	220
30SF036	221
30SF037	219

Cod.	Pag
30SF040	221
30SF044 / 30SF047	219
30SF048 / 30SF051	221
30SF052	219
30SF054	221
30SF056	220
30SF057	220
30SF058 / 30SF061	221
30SF102	219
30SF103	221
30SF114	221
30SF155	220
30SF168	220
30SF180	219
30SF500 / 30SF502	218
30SIL01N / 30SIL02N	224
30SIL03N	225
30SIL04N / 30SIL05N	223
30SIL06N / 30SIL07N	222
30SIL08N	225
30SIL500 / 30SIL504	216/217
30SIL505 / 30SIL506	213
30SIL507	216
30SIL508 / 30SIL509	214
30SM071	133
30SML002	179
30SML003	178
30SMT01	132
30SMTP01 / 30SMTP03	175
30SMTP04	176

Cod.	Pag
30SMTP05	177
30SP0100 / 30SP1000	247
30TB3S	265
30TC50F / 30TC53F	198
30TC54F	199
30TC55 / 30TC56	199
30TE3001R / 30TE3002R	228
30TE6001R / 30TE6002R	228
30TM3001R	229
30TM6001R	229
30TS000 / 30TS016	266/267
30TT104S	265
31CUT01	422
31CUT01 / 31CUT02	228
31CUT03	423
31CUT04	421
32H4X18S / 32H4X22S	253
33H4X20S / 33H4X24S	252
33KITH4X20 / 33KITH4X24	252
34H4X16S / 34H4X20S	253
34KITH4X16 / 34KITH4X20	253
35H4X14S / 35H4X19S	252
35KITH4X19	252
36H4X22S	251
36KITH4X22	251
37H4X22S	250
37KITH4X22	250
38H4X22S	250
38KITH4X22	250
39H4X20S / 39H4X24S	251

39KITH4X20 / 39KITH4X24	251	40-W027	405
3H4X7 / 3H4X13	241	40-W028	405
3H5X7 / 3H5X14	241	40-W030	405
40H4X01 / 40H4X10	246	40-W031	408
40KIT01	466	40W042	501
40LCA001 / 40LCA400	495	40-W043S	409
40LCB000 / 40LCB019	497	40-W049S	404
40LCD003 / 40LCD024	489	40-W051S	405
40LCG001 / 40LCG026	493	40-W052	408
40LCJ000	500	40-W053	405
40LCP002 / 40LCP326	485	40-W055	404
40LCP206 / 40LCP226	483	40-W087 / 40-W090	466
40LCP308N	485	40-W101	466
40LCP508 / 40LCP520	488	40-W106 / 40-W124	466
40LCPN202 / 40LCPN209	486	40-W108	408
40LCPN302 / 40LCPN310	487	40-W125	324
40LCS000 / 40LCS220	491	40-W154	371
40LCS201	499	40-W154	408
40LCV000 / 40LCV027	481	40-W161S	409
40LCV100	498	40-W164A	408
40PI01	466	40W166	501
40-W004	408	40-W167	409
40-W010S	409	40-W188S	405
40-W013S	409	40-W193C	404
40-W014S	409	40-W193S	404
40-W016S	409	40-W194B	404
40-W021	371	40-W194C	404
40-W021 / 40-W022	408	40-W194S	404
40-W022	371	40-W198V / 40-W199V	408
40-W026	409	40-W200	325

40-W20045	325	46H4X18 / 46H4X27	233
40-W206C	404	47H4X15 / 47H4X20	233
40-W206S	404	48H4X18 / 48H4X25	232
40-WA001V	407	49H4X25 / 49H4X29	232
40-WA002 / 40-WA003	407	50-1030	339
40-WA004V	414	50103020STD	339
40-WA005V	414	50-1040	339
40-WA006V	414	50104020STD	339
40-WA007	408	50-1055	339
40-WA008 / 40-WA009	407	50105520STD	339
40-WA010	351	50-1065	339
40WC002 / 40WC326	485	50-2030	338
40WC308N	485	50-2040	338
40WCB001 / 40WCB019	497	50-2055	338
40-WD001 / 40-WD006	403	50-2065	338
40-WF001 / 40-WF012	406	50AD001 / 50AD004	351
40-WM007	411	50-C015 / 50-C045	315
40-WM027	411	50CA604007C	333
40-WM038 / 40-WM039	411	50CA604010C	333
40-WM042	411	50CA604013C	333
40-WM045	411	50CA6040COP	333
40-WM046	411	50-CD100N	315
40-WM506	411	50CHOC01 / 50CHOC010	184
40-WR002 / 40-WR003	411	50CI12X20	374
41H4X9 / 41H4X22	234	50CI16X20	374
42H4X10 / 42H4X28	237	50CI22X14	374
42H5X10 / 42H5X28	237	50CI5050BC	332
43H4X18 / 43H4X20	234	50CI5050ES	332
44H4X14 / 44H4X14	235	50CI540GN	332
45H4X15 / 45H4X20	236	50CIA007 / 50CIA008	332

50CO001 / 50CO002	329	50PE30 / 50PE70	366
50CO30X12	374	50PI01 / 50PI05	365
50CO35X14	374	50PR002	305
50CO40X16	374	50QG03 / 50QG15	321
50COL01 / 50COL07	364	50RAS1 / 50RAS2	362
50COL50 / 50COL51	392	50RAS4 / 50RAS7	361
50CP01	397	50RIO1	330
50-CS100	315	50RTA1 / 50RTA2	363
50CS200	313	50RTD1	363
50CSBA	313	50RTF1 / 50RTF2	363
50CSTE15 / 50CSTE45	313	50RTL1 / 50RTL2	363
50DF138 / 50DF198	372	50RTO1 / 50RTO2	363
50ES01 / 50ES02	297	50RTP1 / 50RTP2	363
50FA01 / 50FA06	359	50RTS1	363
50FL00	384	50RTT1	363
50FL00C	384	50RTV1 / 50RTV2	363
50FLAN2	384	50SA150B / 50SA250B	357
50FLAN2T	384	50SC350 / 50SC400	354
50GD0015 / 50GD0018	298	50SG250B	355
50GD0015 / 50GD0037	385	50SG350B / 50SG250V	355
50GD0022	203	50SI01 / 50SI02	328
50GD0027	203	50SIR01	328
50GD0037	203	50SL300B / 50SL370B	357
50GD2040	385	50SP300B / 50SP400B	356
50GD3060	385	50SPA01 / 50SPA04	358
50GIRA02	247	50SPANG01 / 50SPANG04	358
50GO275 / 50GO400	355	50SPB30	317
50LE001	301	50SPB30	320
50LE001	373	50SPB30 / 50SPB43	372
50MC001	306	50SPB43	315

50SPB43	320	51VP026010 / 51VP026025	474
50SR340	356	52BO13PC	389
50ST16 / 50ST40	397	52BO13PP	389
50T001 / 50T002	331	52BO17PC	389
50T003	331	52BO17PP	389
50TLM03	320	52BO23PC	389
50TLM05	320	52BO23PP	389
50TLMINI	320	52BO28PC	389
50TLS03 / 50TLS05	320	52BO28PP	389
50TLSPECIAL	320	52BO32PC	389
50VA001A / 50VA001V	341	52BO32PP	389
50VP00402	475	52BO38PC	389
50VP0500 / 50VP0800	476	52BO38PP	389
50VP0508 / 50VP0808	476	52KIT27	249
50VP201008	476	53GP01	247
50VP202008	476	53TA60402	386
50VP251208	476	53TA60404	386
50VP252508	476	53TAF40302	386
50VP601008	476	53TAF40304	386
50VP602508	476	53TAF60404	386
50WA004B	414	53TL60402	386
50WA005B	414	53TL60404	386
50WA006B	414	55TP6080	391
50ZES01 / 50ZES03	365	5H25X14 / 5H25X18	203
51CF6040	379	5H35X14 / 5H25X18	240
51MA0032	229	5H35X14 / 5H35X18	203
51MP6040	378	5H4X10 / 5H4X30	240
51VP014510 / 51VP014525	474	5H5X10 / 5H5X30	240
51VP016010 / 51VP016025	474	5H6X6 / 5H6X12	240
51VP024510 / 51VP024525	474	70H402 / 70H602	245

71H402 / 71H602	245	90-2009	152
80-0106 / 80-0306	455	90-2010	151
80-0108 / 80-0308	455	90-2026	151
80-2003 / 80-2008	467	90-2102	161
80A0900 / 80A1100	455	90-2316	161
80A0908 / 80A1108	455	90-2346	161
80A1300	453	90-2353	152
80A1400 / 80A1600	449	90-2354	152
80A1700 / 80A1800	451	90-2355	152
80A1900	458	90-2356	152
80D0100 / 80D0400	437	90-4108 / 90-4109	125
80D0500 / 80D0800	436	90-P9645	107
80D0900 / 80D1000	435	90-P9661	107
80D1900 / 80D2000	438/439	90-P9662	107
80DM01 / 80DM03	468	AG00206N / AG00208N	288
80ET007 / 80ET009	68	AG00501	290
80RIC02 / 80RIC05	451	AG00606	291
8H4X10 / 8H4X30	241	AG00706 / AG00706P	290
90-1000	107	AG00708 / AG00708P	290
90-1001	46	AG00906 / AG00906P	289
90-1004	46	AG00908 / AG00908P	289
90-1026	46	AG00930	290
90-1212	46	AG01410 / AG01430	287
90-12816	107	AG01701 / AG01801	291
90-13040	107	AG01710	291
90-13064	106	AG01720	291
90-13179	107	AG03000	288
90-14243	107	AG03108	288
90-15303	107	AG03206	288
90-2008	151	AG03306	288

AG03640 / AG03650	289	BPL6	351
AG03720 / AG03730	287	BR 330 / BR 332	348
AG04610	289	BRU	351
AG05301	290	BS ---	348
AG05601 / AG05801	469	BS 10 S	345
AG05820	471	BS 10 T	345
AG07701 / AG07701P	469	BS 102 / BS 118	345
AG07901	469	BST100	278
AG09002 / AG09003	281	BT 202 / BT 224	345
AG362512POLB / AG362512POLN	280	BX ---	346/350
AG36258POLB / AG36258POLN	280	CANNELLO PRO	401
AR0001 / AR00011	473	CANNELLOBIG	401
AR0001B / AR00011B	473	CANNOLO	374
AR02801	473	CAP2B / CAP4	393
BA1008 / BA1020	287	CFTRA1 / CFTRA6	388
BA1208 / BA1220	287	CHASIL 1/34	105
BA1508 / BA1520	287	CHIT15 / CHIT30	317
BA1808 / BA1830	287	CHITBA24	316
BA2008 / BA2030	287	CHITBAD24	317
BASKET 102 / 208	391	CHITMINI / CHITMINI30	316
BC 320 / BC 330	345	CHITMINID22	317
BD 301 / BD 302	349	CHITMINID30	317
BF 0867 / BF 0869	345	CHITP	317
BF 310 / BF 319	345	CHITRIC 6/D	315
BIM 230 / BIM 340	350	CHITRIC 8 / CHITRIC 10	315/317
BO100N / BO1000N	384	CHOCOBIGEV	192
BOS 26	352	CHOCOBIGRING06	192
BOS 36 BIG	352	CHOCOFONT	193
BOS12FLO	349	CHOCOFORK	184
BOSPL1 / BOSPL3	351	CHOCORING06	193

CIOK 1	330	COD. 32416	446
CLP01	271	COD. 32418	446
CLPESPO21	271	COD. 32717	445
CLPESPOB / CLPESPOBTRA	271	COD. 32901	444
COATING	498	COD. 33118	447
COD. 101 / COD. 102	465	COD. 504	460
COD. 103 / COD. 104	464	COD. 510	442
COD. 130 / COD. 132	459	COD. 603	443
COD. 150	462	COD. 604	445
COD. 152 / COD. 153	462	COD30400 / COD30408	446
COD. 155	464	COD32100 / COD32108	446
COD. 158	464	COD33201	443
COD. 159	462	COD33301	443
COD. 160 / COD. 163	461	COD33401	442
COD. 180	463	COD33501	440
COD. 183 / COD. 185	463	COD33608	445
COD. 188	463	COD33701	441
COD. 190	463	COD33906	441
COD. 192	463	COD34001	441
COD. 201 / COD. 204	467	COD35101	445
COD. 203	467	COD512 / COD514	456/457
COD. 204	467	COD60501	443
COD. 300 / COD. 301	447	COLONNA	465
COD. 304	446	COLONNINA	465
COD. 305 / COD. 307	442	COVER 3 / COVER 8	327
COD. 308	447	COVER 3H4	327
COD. 309 / COD. 310	441	COVER3H45	327
COD. 320	441	COVER3H48	327
COD. 321	446	CS3	375
COD. 322	446	CSL	375

CSM040	319	EXTRA C	259
CSM04001 / CSM04009	319	FLACONE / FLACONE2	384
CSM0402	318	FLAN1	384
CSM060	319	FLEX 025 CM / 070 CM	343
CSM06001 / CSM06009	319	FONTANINA	465
CSM0602	318	GD 01 / GD 22	415
CSMSPB40 / CSMSPB60	372	GIRA / GIRA7	324
CUT---	380/381	GL 7 / GL 9	401
CUTTER 1 / CUTTER 15	392	GL1 / GL3	394
DECOAIR 2 / DECOAIR 6	410	GL10 / GL11	394
DECOCP02	411	GL18PRE	394
DECOF01	411	GL25PRE	394
DECOH01	411	GS03 / GS22	415
DECOMP 7 / DECOMP9	410	GST01 / GST10	279
DECOR 30	375	GSTESPOB	279
ED 1 / ED 9	255	GTB01 / GTB19	382
EFSD001	403	INOX 3	417
EL101 / EL201	181	KITMS1 / KITMS4	413
EL306	181	LAMP01	400
EM 1 / EM 13	257	LAMPLEX	401
EM 16	258	MA1002	39
ESPICE14	278	MA1003 / MA1006	32
ESPO ST	353	MA1008	36
ESPOB60	353	MA1009	36
ESPOBO32	353	MA1011	41
ESPOP30	353	MA1012	41
ESPOP40	353	MA1013	26
ESPOP55	353	MA1014	26
ET003 / ET004B	69	MA1015	26
EUROCHOCK	499	MA1016	26

MA1017	48
MA1018	41
MA1019	39
MA1020	43
MA1021 / MA1024	31
MA1025	42
MA1026 / MA1030	83
MA1032	39
MA1033 / MA1036	35
MA1037	39
MA1038 / MA1040	30
MA1041	29
MA1042	29
MA1043	29
MA1044	25
MA1045	25
MA1046	39
MA1047	21
MA1048	25
MA1049	25
MA1050	23
MA1051	22
MA1052	20
MA1053	47
MA1054	47
MA1055	47
MA1056	47
MA1064	41
MA1074	42
MA1082	39

MA1091	42
MA1094	39
MA1281	41
MA1293	41
MA1303	41
MA1335	41
MA1350	41
MA1513	46
MA1521	41
MA1527	40
MA1529	40
MA1530	39
MA1603	41
MA1604	41
MA1606	41
MA1607	40
MA1609	41
MA1610	42
MA1611	41
MA1612	40
MA1613	46
MA1616	40
MA1617	40
MA1618	40
MA1619	42
MA1620	40
MA1621	40
MA1622	40
MA1624	42
MA1625	40

MA1626	41
MA1627	41
MA1629	41
MA1631	39
MA1632	41
MA1633	40
MA1636	41
MA1637	40
MA1638	40
MA1640	41
MA1800	42
MA1801	42
MA1802	42
MA1803	42
MA1804	42
MA1805	77
MA1806	77
MA1807	66
MA1900	42
MA1901	42
MA1903	42
MA1904	42
MA1905	42
MA1907	40
MA1910	77
MA1913	77
MA1914	77
MA1915	77
MA1916	77
MA1917	77

MA1918	75
MA1919	75
MA1920 / MA1922	74
MA1923	77
MA1924	75
MA1925	41
MA1926	75
MA1927	41
MA1951 / MA1954	85
MA1958	44
MA1961	44
MA1962	46
MA1963	42
MA1964	42
MA1965	42
MA1966	42
MA1968	42
MA1969	27
MA1970	27
MA1971	27
MA1972	41
MA1974	49
MA1975	49
MA1977	44
MA1980	42
MA1981	42
MA1982	43
MA1983	43
MA1984	43/265
MA1984	49

MA1985	43	MA2016	57
MA1986	43	MA2017	57
MA1987	43	MA2019	54
MA1988	43	MA2020 / MA2021	64
MA1989	43	MA2022	55
MA1990	49	MA2023	59
MA1991	49	MA2024	60
MA1991	120	MA2025	60
MA1992	48	MA2026	59
MA1993	46	MA2027	53
MA1993 / MA1994	34	MA2028	52
MA1994	44	MA2029	53
MA1997	27	MA3005	103
MA1998	27	MA3006	85
MA1999	27	MA3007	41
MA2000	66	MA3008	116
MA2001	66	MA3009	116
MA2002	81	MA3010	116
MA2003	43	MA3011	116
MA2004	66	MA3011	49
MA2005	66	MA3012	115
MA2006	80	MA3013	115
MA2007	80	MA3014	115
MA2008	63	MA3016	156
MA2009	63	MA4005 / MA4007	37
MA2010	66	MA4010 / MA4012	33
MA2011 / MA2012	65	MA5000	43
MA2013	56	MA5002 / M5010	45/ 122
MA2014	56	MA5008	43
MA2015	54	MA6001	81

MA6002	80	MAC620S	160
MA6003	81	MAC630S	160
MA6004	81	MAC661S	160
MA6005	80	MAC720S	160
MA6006	81	MAC800S	160
MA6100 / MA6103	76	MAC801S	160
MA7000 / MA7002	73	MAC822S	160
MAC000S	125	MAC823S	160
MAC001S	125	MAC870S	160
MAC140S	124	MAC950S	160
MAC170S	124	MACLO1	184
MAC281S	124	MASK 5 / MASK 199	413
MAC310S	124	MASK M3 / MASK M7	413
MAC320S	124	MASK R10 / MASK R16	413
MAC321S	124	MC000305	190
MAC322S / MAC323S	129	MC001001	191/286
MAC324S / MAC325S	162	MC09G	190
MAC326S	131	MC09L	190
MAC330	131	MC09N	190
MAC405S / MAC406S	162	MC09R	190
MAC407S	124	MC09V	190
MAC408S	124	MC10	191/286
MAC409S	124	MC100 / MC108	189
MAC411S	124	MCD101 / MCD104	187
MAC412S	125	MD 2	411
MAC413S	125	MEL 250 / MEL 450	355
MAC421S	125	METAL3 / METAL8	467
MAC602S / MAC604S	158	MEX 250 / MEX 500	357
MAC611S / MAC614S	158	MFRU 25 / MFRU 50	359
MAC615S / MAC616S	159	MICROMAT30 / 60	203

MICROMAT30 / 60	387	PALL1	299
MIGNON A001 / A009	255	PC55 / PC120	369
MIGNON B001 / B009	255	PD1/2	416
MIGNON C001 / C009	255	PD11/12	417
MIP	477	PD13/14	416
MIR01 / MIR17	477	PD3/4	416
MIS05 / MIS08	477	PD5/6	416
MONOP. A001 / A0013	257	PDM1/2	416
MONOP. A0016	258	PDM3/4	416
MONOP. B001 / B0013	257	PDM7/8	416
MONOP. B0016	258	PDM9/10	416
MONOP. C001 / C0013	257	PDS1/2	416
MONOP. C0016	258	PDS3/4	416
MONOP. C101	259	PDS5/6	416
MRTE	401	PINZA	366
MSC001 / MSC004	184	PINZAX1	366
MSC201 / MSC202	184	PINZAX2	366
MSP 250 / MSP 350	357	PINZAX3	366
MTE	401	PINZAX4	366
NSA H 25 / H 60	260/309	PL00100 / PL00102	431
NSA25X150	261	PL00200 / PL00202	431
NSA27X27MO	261/320	PL00300 / PL00302	431
NSA300X300	261	PMFORK	414
NSA30X240	261	PMFT001 / PMOFT001C	421
NSA39X39MO	261/320	PMKNIFE	414
NSA400X600	261	PMO07.00 / PMO07/C	426
NSA40X240	261	PMO08.00	429
NSA60X40MO	261	PMO09 / PMO11	432
ONE06 / 22	211	PMO12 / PMO14	433
ONE14H35 / ONE14H40	211	PMOCE001 / PMOCE003	425

PMOCL001 / PMOCL001C	422	PPT14X	375
PMOCO001 / PMOCO003	427	PPT16X	375
PMOCO004 / PMOCO005	428	PPT18X	375
PMOCO006	427	PPT8X	375
PMOCO007	428	PR30 / PR40	367
PMOCO008 / PMOCO010	425	PR30X30	367
PMOCO011 / PMOCO012	425	PR40X60	367
PMOCO013 / PMOCO014	424	PR50X50	367
PMOCO015	425	PRA 9	381
PMOCU001/ PMOCU003	430	RAS 3	362
PMOCU002/C / PMOCU003/C	430	RC110 / RC115	362
PMOCU002/C	426	RD105 / RD175	362
PMOCU004	426	RD150	362
PMOJA001 / PMOJA002	426	RDC180X200	370
PMOLO001 / PMOLO001/C	427	RELIEF1 / RELIEF12	417
PMOPE001	424	RETH4 / RETH5	242
PMOTO001 / PMOTO004	429	RETSPECIAL 1	243
PMOTO005 / PMOTO005/C	423	RETSPECIAL 2	243
PMOVA001 / PMOVA003	433	RFP 6 / RFP 12	369
PMSPoon	414	RFP12INOX	369
POMP	401	RIGA64	385
PORTFLACONE	384	RL 1 / RL 4	371
PPT 12	375	RLS30 / RLS60	371
PPT 12/16	375	RLS50PE / RLS70PE	371
PPT 12/18	375	ROLL H 30 / H 65	340
PPT 14/16	375	ROLLH3020STD	340
PPT 14/18	375	ROLLH4020STD	340
PPT 8/12	375	ROTAPINOX 5 O	368
PPT10X	375	ROTAPINOX 5 P	298
PPT12X	375	ROTAPINOX 5 P	368

ROTAPINOX 7 O	368	SILICOPAT1/B / 4/ B	387
ROTAPINOX 7 P	368	SILICOPAT1/R / 7 / R	387
ROTINOX 5 P/O	368	SM 1000	151
ROTINOX 7 P/O	368	SM 2000	151
RPL 6 / RPL 12	369	SM 2300	151
RPL12INOX	369	SM 2500	151
RPS 6	369	SM 3000	151
RSC180X140	370	SM 3500	151
RSC180X200	370	SM 4000	151
RSC70X100	370	SMA110 / SMA320	383
RSC96X153	370	SPB SPECIAL	373
RSC97X210	370	SPINNER	323
RTC180X200	370	SPR034 / SPR050	342
RTRA1-5	285	SPR034/C / SPR050/C	342
SAC45X100	341	SPZ INOX	393
SAC58X100	341	SPZ PL1	393
SBIKIT01	278	SPZ SE	393
SCC01	85	ST2 / ST4	265
SCM 30 / SCM 40	356	STD 025 CM / 075 CM	343
SCSP01	414	STPK	390
SCSP03	414	STPTA 1 / STPTA 8	390
SEG001N /SEG027N	395	STPZ	390
SES 100 / SES 1500	389	SUT25X17	151
SET DISK	397	SUT28X18	151
SETAC16 / SETAC30	367	SUT34X25	151
SETACIOK2	367	SUT40X27	151
SETACIOK2	413	SUT45X32	151
SFT 118/Y / 522/Y	226	SUT54X36	151
SG 01 / SG 09	227	SUT64X43	151
SGM00 / SGM100	283	SUT75X50	151

<b>TAG5</b>	385	<b>VC60X408</b>	327
<b>TAV --</b>	396	<b>VP00101</b>	471
<b>TEFLONPAT5</b>	387	<b>VP00206</b>	475
<b>TFL10 / TFL15</b>	417	<b>VP00301</b>	475
<b>TFRU 25 / TFRU 50</b>	359	<b>VP00401</b>	475
<b>TL 03 / TL 15</b>	321	<b>VP00401</b>	475
<b>TPB1</b>	259	<b>VP00500</b>	475
<b>TPEX 1</b>	259	<b>VP00501</b>	475
<b>TPG 1 /TPG 13</b>	257	<b>VP00501</b>	475
<b>TPG 16</b>	258	<b>VP00601</b>	475
<b>TPIDEA01 / TPIDEA03</b>	263	<b>VP00700</b>	475
<b>TPM 1 /TPM 9</b>	255	<b>VP00801</b>	475
<b>TS1</b>	324	<b>VP00906</b>	475
<b>VASSOIOAMI</b>	327	<b>VP00906</b>	475
<b>VASSOIOAMO</b>	327	<b>VP01001</b>	475
<b>VASSOIOBMI</b>	327	<b>VP01001</b>	475
<b>VASSOIOBMO</b>	327	<b>VP01106</b>	475
<b>VASSOIOCFMI</b>	327	<b>VP01201</b>	475
<b>VASSOIOCMO</b>	327	<b>ZENBO00 / ZENBO02</b>	431
<b>VB00102</b>	473	<b>ZENBO00C</b>	431
<b>VB00201 / VB00208</b>	471	<b>ZENTR00 / ZENTR02</b>	431
<b>VB00306</b>	472		
<b>VB00308</b>	472		
<b>VB00408</b>	472		
<b>VB00501</b>	473		
<b>VB00804</b>	472		
<b>VB00904 / VB00908</b>	471		
<b>VC30X40</b>	327		
<b>VC60X40</b>	327		
<b>VC60X404</b>	327		



**Martellato srl, ai sensi della Legislazione Comunitaria vigente:**

Regolamento CE n. 1935/2004  
Materiali e oggetti destinati a venire a contatto con i prodotti alimentari.

Regolamento UE n. 10/2011 e smi  
Riguardante i materiali e gli oggetti di materia plastica  
destinati a venire a contatto con i prodotti alimentari.

Regolamento CE n. 2023/2006  
Buone pratiche di fabbricazione (GMP) dei materiali e degli oggetti  
destinati a venire a contatto con i prodotti alimentari.

**E alla seguente Legislazione Nazionale vigente:**

D.M. Italiano 21/03/1973 e successive modifiche  
Disciplina igienica degli imballaggi, recipienti, utensili, destinati a venire a contatto  
con le sostanze alimentari o con sostanze d'uso personale.

D.P.R. 777/82 e successivi aggiornamenti e modifiche

**Ha emesso uno specifico Capitolato che obbliga i suoi fornitori al rispetto  
di determinate precauzioni igieniche durante la fabbricazione,  
lavorazione e imballo degli articoli Monouso elencati nel presente catalogo.  
Per tutti gli altri articoli la Martellato srl richiede all'utilizzatore la precauzione  
di lavarli accuratamente con acqua e detergente neutro prima dell'uso.**

**Martellato srl, accordingly to EC laws:**

EC Regulation no. 1935/2004  
Materials and articles intended to come into contact with food.

EU Regulation no. 10/2011 and smi  
Regarding the materials and plastic articles intended to come into contact with food.

EC Regulation no. 2023/2006  
Good Manufacturing Practices (GMP) of materials and articles intended to come into contact with food.

**And to the following National Legislation in force:**

Italian Ministerial Decree 21/03/1973 and subsequent updates and changes  
Hygiene regulation for packaging, containers, utensils, intended to come into contact with food  
or with substances for personal use.

**Presidential Decree 777/82 and subsequent updates and changes**

**Issued a specification that requires its suppliers to comply with certain hygienic precautions  
during manufacture, processing and packaging of the disposable items listed in this catalogue.  
For all other items Martellato srl asks users to wash thoroughly  
with water and mild detergent before use, as a precaution.**

MARTELLATO si riserva la facoltà di modificare in qualsiasi momento e senza preavviso  
le caratteristiche tecniche degli articoli presentati in questo catalogo.  
È vietata la riproduzione, anche parziale, di questo catalogo senza l'autorizzazione di MARTELLATO

MARTELLATO reserves the right to modify at any time without notice the technical specifications of the items in this catalogue.  
Any reproduction, even partial, of this catalogue without permission is strictly prohibited.



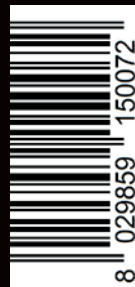

CATGEN23MINI



**Martellato**

Martellato srl - Via Rovigo, 1/B - 35010 Vigonza PD - Italy  
tel. +39 049 7800155 - fax +39 049 8087744  
martellato@martellato.com - www.martellato.com